

GPIO4D User Guide

3/29/10

Overview

The GPIO4D allows MPU11 based control systems to interface to third party servo drives that accept -10 to +10 VDC current or velocity requests. The GPIO4D combines the functions of a PLC and third party drive interface to reduce system component count and increase value.

GPIO4D Features

Application:	Third Party Drive Interface
Number of Axes:	4
Maximum number of Axes:	4
DAC resolution:	16 bits
Analog Output Voltage:	-10 to +10 Volts
General Purpose Digital Inputs:	16
General Purpose Digital Outputs:	16
Control Interface:	2 fiber optics to MPU11 motion control card
Dimensions (W*D*H):	12 * 5 * 0.75 inches

GPIO4D Connection Overview

The GPIO4D communicates with an MPU11 motion control card through two optical fibers. The PLC protocol fibers (1 and 3) handle communication of drive interface signals as well as general purpose I/O. Encoder feedback returns directly to the MPU11.

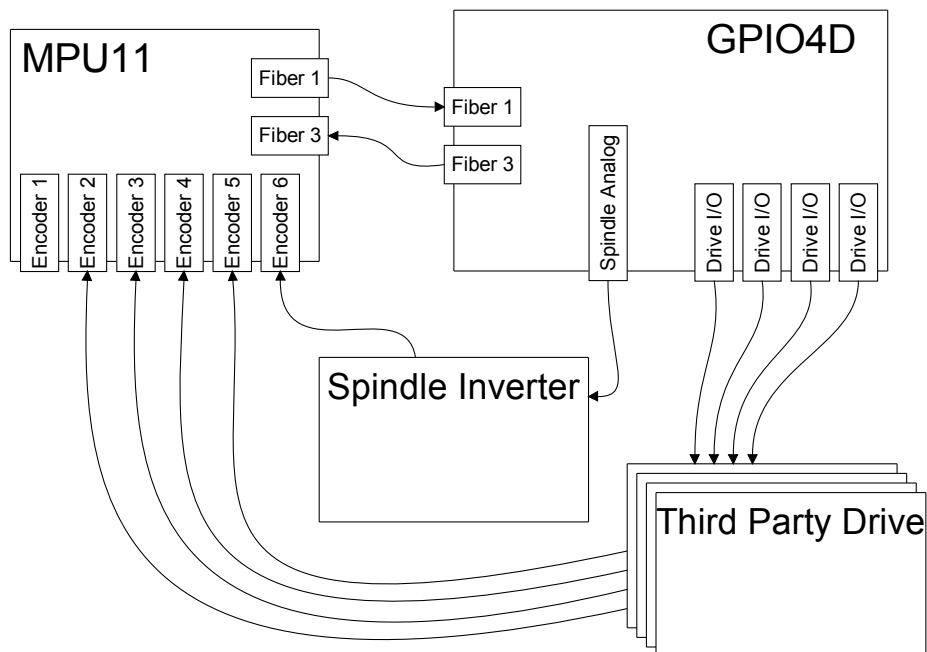

GPIO4D Outputs

Sixteen general purpose relay outputs and four axis enable outputs are available on the GPIO4D. Four axis brake outputs and a fault output are also provided, but are not part of the PLC I/O space. The brake outputs follow the state of their axis enables. The fault output will remain closed as long as the GPIO4D does not detect any serious errors, such as a loss of communication.

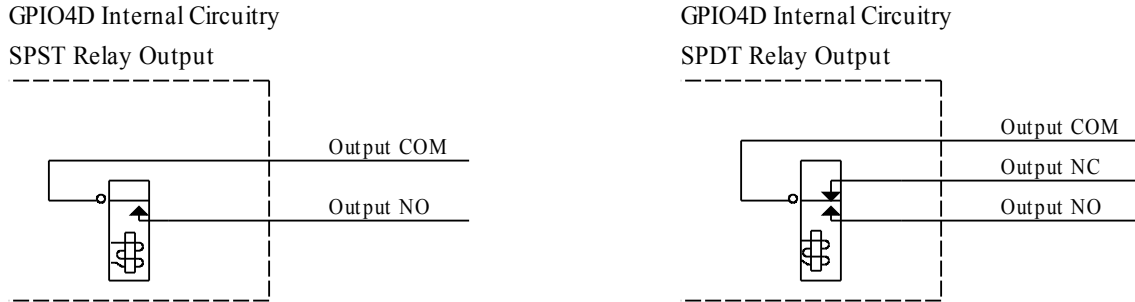

Motor Brake and Enable Outputs

Each axis has brake and enable outputs, which are functionally equivalent. These open collector outputs may be used to drive a relay to release axis brake solenoids or activate an enable input on a servo drive. Note that the GPIO4D has no noise suppression on the outputs. Appropriate suppression must be added to devices connected to the open collector outputs. Typically, a DC relay coil is driven by a brake output and a diode is placed across the coil leads to suppress voltage transients, as in the wiring example. Motor brake mechanisms may also require noise suppression, such as a resistor and capacitor network for AC solenoids or a diode for DC solenoids.

Typical Brake Wiring Example

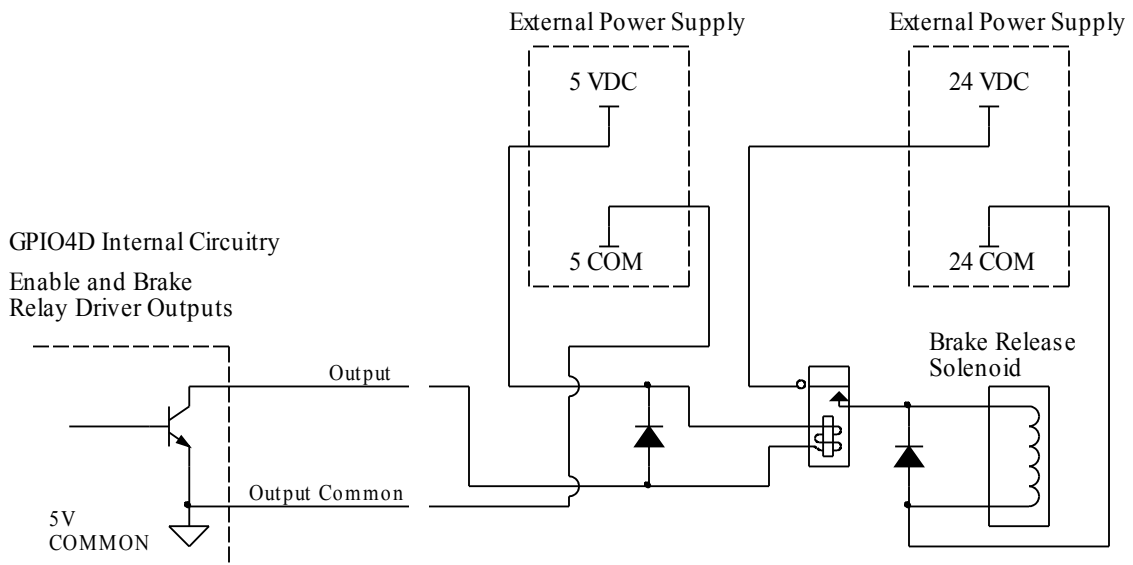

Analog Outputs

Five analog outputs are provided by the GPIO4D. Four analog outputs are used to request motion from servo drives. These motion request outputs have 16 bit resolution and a fixed output range of -10V to +10V. Motion request analog channels are digitally trimmed at the factory. The remaining analog output is used to request a spindle speed from an inverter. The spindle analog output has 12 bit resolution and an output range from 0 to 10V. Minor adjustment can be made to the spindle analog output range using the “OFFSET” potentiometer (pot) (VR4) and “GAIN” pot (VR2). Only adjust the “OFFSET” pot at the minimum possible spindle speed. This adjustment is intended only to null the voltage level when 0 RPM is commanded. The “GAIN” pot should be used at maximum speed to match actual RPM with commanded RPM. Adjustments to the analog output should be very minor and cannot be used to compensate for incorrect inverter or control settings. VR1 and VR3 pots should not be used. If VR1 has been turned, measure from TP11 to analog common and adjust the voltage back to 2.5V. If VR3 has been turned, measure from TP13 to analog common and adjust the voltage back to 5.0V.

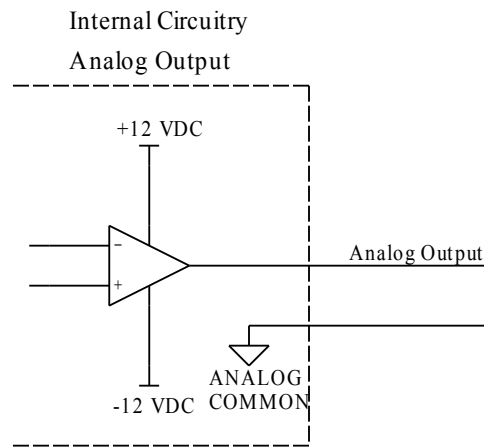

GPIO4D Inputs

The GPIO4D has 16 general purpose inputs and 4 drive fault inputs. Inputs are divided into banks of four. Each bank is configurable for various voltages and sinking or sourcing polarity. Voltage may be selected by installing the appropriate value resistor pack or SIP into a socket for each bank. Polarity is determined by wiring the common terminal for the bank to the supply positive or supply common.

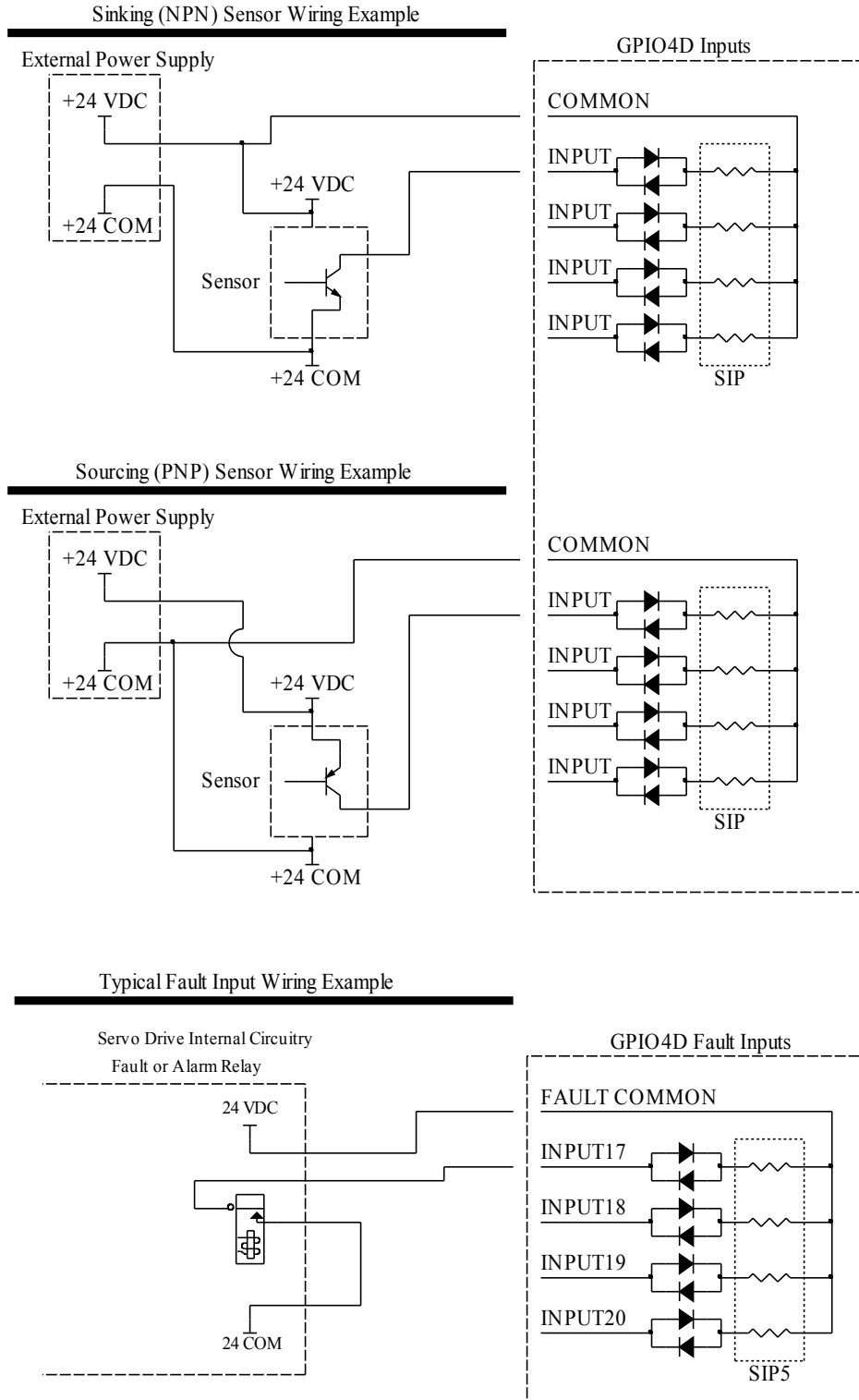

SIP Identification - XXX Indicates Value

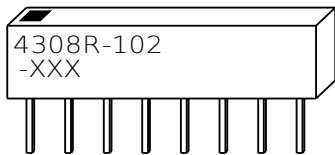

SIP Internal Wiring / Pinout

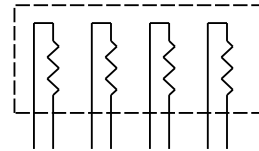

SIP Input Voltage Selection

SIP Value Marking	Resistor Value (Ohms)	Input Voltage
471	470	5
102	1.0k	12
222	2.2k	24

PLC Expansion

PLC I/O expansion is possible through the four “PLC ADD” connectors. Each PLC expansion port can accept 16 – 128 inputs, outputs, or inputs and outputs in 16 bit increments. This allows for digital I/O, DACs, ADCs, or other devices to be added to the system as needed.

PLC ADD 1 – 4 Connector Pinouts

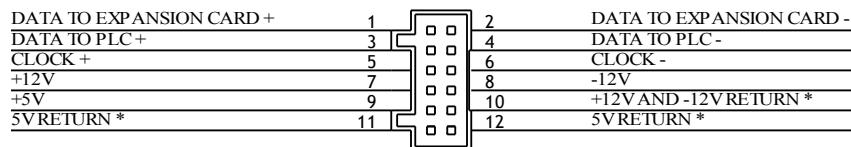

* +12V AND -12V RETURN and 5V RETURN are connected on the GPIO4D

PLC I/O is arranged in 16 bit groups or slots. As a general rule, slots 0-14 are used for individual I/Os such as switches and have a programmable debounce time for the inputs. Slots 15-47 are reserved for ADCs, DACs, or other devices that do not require debounce. Every device using I/O space must use space in 16 bit multiples by reserving slots. PLC expansion boards with inputs and outputs must have a matching number of input and output slots.

A GPIO4D uses 2 slots for its inputs and 7 slots for outputs. Since I/O space must be reserved in 16 bit increments, some I/O space is lost. For example, the GPIO4D has 20 inputs which reserve 2 slots or 32 inputs, leaving 12 inputs unused. Also note that the GPIO4D outputs are not assigned contiguously. The individual outputs take slots 0-1, while the DACs are assigned to the group output area starting at slot 15.

Assignment of I/O slots occurs sequentially starting at the main PLC, then PLC ADD port 1, PLC ADD port 2, etc. In the “GPIO4D I/O Organization” example, GPIO4D I/O will always be at the same location since local PLC resources are assigned slots first. Other devices may change locations if they are plugged into PLC ADD ports in a different order. Devices plugged into the PLC ADD ports that require debounce will be assigned starting at the slots marked “A”, while devices that do not require debounce will start being assigned at the slots marked “B”.

GPIO4D I/O Organization

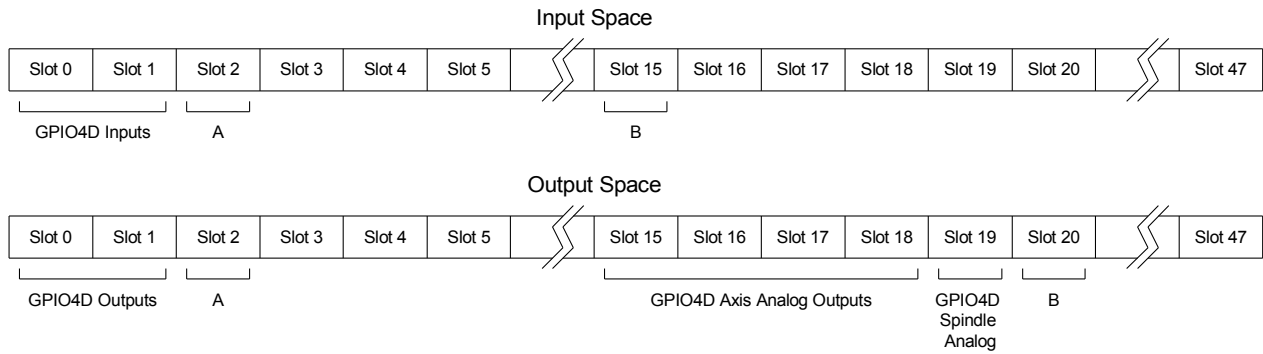

GPIO4D I/O Map

Input Map

Output Map

Input Specification			Input Location	
Number	Function	Type	Connector	Pin
1	General Purpose	Configurable	H10	1
2	General Purpose	Configurable	H10	2
3	General Purpose	Configurable	H10	3
4	General Purpose	Configurable	H10	4
5	General Purpose	Configurable	H10	6
6	General Purpose	Configurable	H10	7
7	General Purpose	Configurable	H10	8
8	General Purpose	Configurable	H10	9
9	General Purpose	Configurable	H9	1
10	General Purpose	Configurable	H9	2
11	General Purpose	Configurable	H9	3
12	General Purpose	Configurable	H9	4
13	General Purpose	Configurable	H9	6
14	General Purpose	Configurable	H9	7
15	General Purpose	Configurable	H9	8
16	General Purpose	Configurable	H9	9
17	Drive Fault 1	Configurable	H14	3
18	Drive Fault 2	Configurable	H13	3
19	Drive Fault 3	Configurable	H12	3
20	Drive Fault 4	Configurable	H11	3

Output Specification			Output Location	
Number	Function	Type	Connector	Pin
1	General Purpose	Relay SPST	H1	1,2
2	General Purpose	Relay SPST	H1	3,4
3	General Purpose	Relay SPST	H1	5,6
4	General Purpose	Relay SPST	H1	7,8
5	General Purpose	Relay SPST	H1	9,10
6	General Purpose	Relay SPST	H1	11,12
7	General Purpose	Relay SPST	H1	13,14
8	General Purpose	Relay SPDT	H1	15,16,17
9	General Purpose	Relay SPDT	H1	18,19,20
10	General Purpose	Relay SPST	H1	1,2
11	General Purpose	Relay SPST	H1	3,4
12	General Purpose	Relay SPST	H1	5,6
13	General Purpose	Relay SPST	H1	7,8
14	General Purpose	Relay SPST	H1	9,10
15	General Purpose	Relay SPST	H1	11,12
16	General Purpose	Relay SPST	H1	13,14
17	Drive Enable 1	Open Collector	H14	5
18	Drive Enable 2	Open Collector	H13	5
19	Drive Enable 3	Open Collector	H12	5
20	Drive Enable 4	Open Collector	H11	5
17	Axis 1 Brake	Open Collector	H14	6
18	Axis 2 Brake	Open Collector	H13	6
19	Axis 3 Brake	Open Collector	H12	6
20	Axis 4 Brake	Open Collector	H11	6
241-256	Axis 1 Analog	16 bit DAC	H14	1
257-272	Axis 2 Analog	16 bit DAC	H13	1
273-288	Axis 3 Analog	16 bit DAC	H12	1
289-304	Axis 4 Analog	16 bit DAC	H11	1
305-316	Spindle Analog	12 bit DAC	H6	11
317-320	Reserved			
	Fault	Relay SPDT	H2	15,16,17

*Note: Outputs 17-20 each control two physical outputs

GPIO4D Specifications

Characteristic	Min.	Typ.	Max.	Unit
5 Volt Supply Current	1.4	-	-	A
12 Volt Supply Current	0.09	-	-	A
-12 Volt Supply Current	0.07	-	-	A
Input Pullup Voltage (Vinp)	4.5	5	25	V
Input On Voltage	Vinp-1.25	-	-	V
Input Off Voltage	-	-	1.25	V
Input Operating current	9	11	15	mA
Relay Output Current	0.1	-	10	A @ 125VAC
Relay Output Current	0.1	-	5	A @ 30VDC
Open Collector Output Current	-	10	90	mA
Open Collector Output Voltage	-	5	25	V
Spindle Analog Output Resolution	-	12	-	bits
Spindle Analog Output Voltage	0	-	10	V
Spindle Analog Output Current	0	1	20	mA
Axis Analog Output Resolution	-	16	-	bits
Axis Analog Output Voltage	-10	-	10	V
Axis Analog Output Current	0	1	20	mA
PLC ADD Port 5V Current Output*	0	-	1	A
PLC ADD Port 12V Current Output*	0	-	0.8	A
PLC ADD Port -12V Current Output*	0	-	0.8	A
Fiber 1 and 3 Length	-	-	100	feet
Size: 12 * 5 * 0.75 (W*D*H)				Inches

*PLC ADD Port Current is a total for all 4 ports in any combination. The power supply may be the limiting factor; make sure it can handle the GPIO4D current ratings in addition to the PLC Expansion board requirements.

GPIO4D Troubleshooting

Symptom	Possible Cause	Corrective Action
PLC OK LED out	Motion control card hasn't booted up	Start software, wait for the main screen to load
	Fibers 1 or 3 connected incorrectly or faulty	Check connections one at a time, swap with a known good set of fibers
All status LEDs out	Logic power not applied	Measure AC coming into power supply, correct wiring or supply problems
5V, +12V, or -12V LED out	Power supply or connection problem	Measure AC coming into power supply, correct wiring or supply problems
3.3V LED out, 5V LED lit	Internal Problem	Return for repair
Input doesn't work with sensor	Incorrect wiring	Correct wiring for sensor type (sinking or sourcing), check that SIP values are appropriate for the input voltage
	Voltage drop across sensor is too high	Use 3-wire sensors with lower voltage drop spec.

GPIO4D Connections

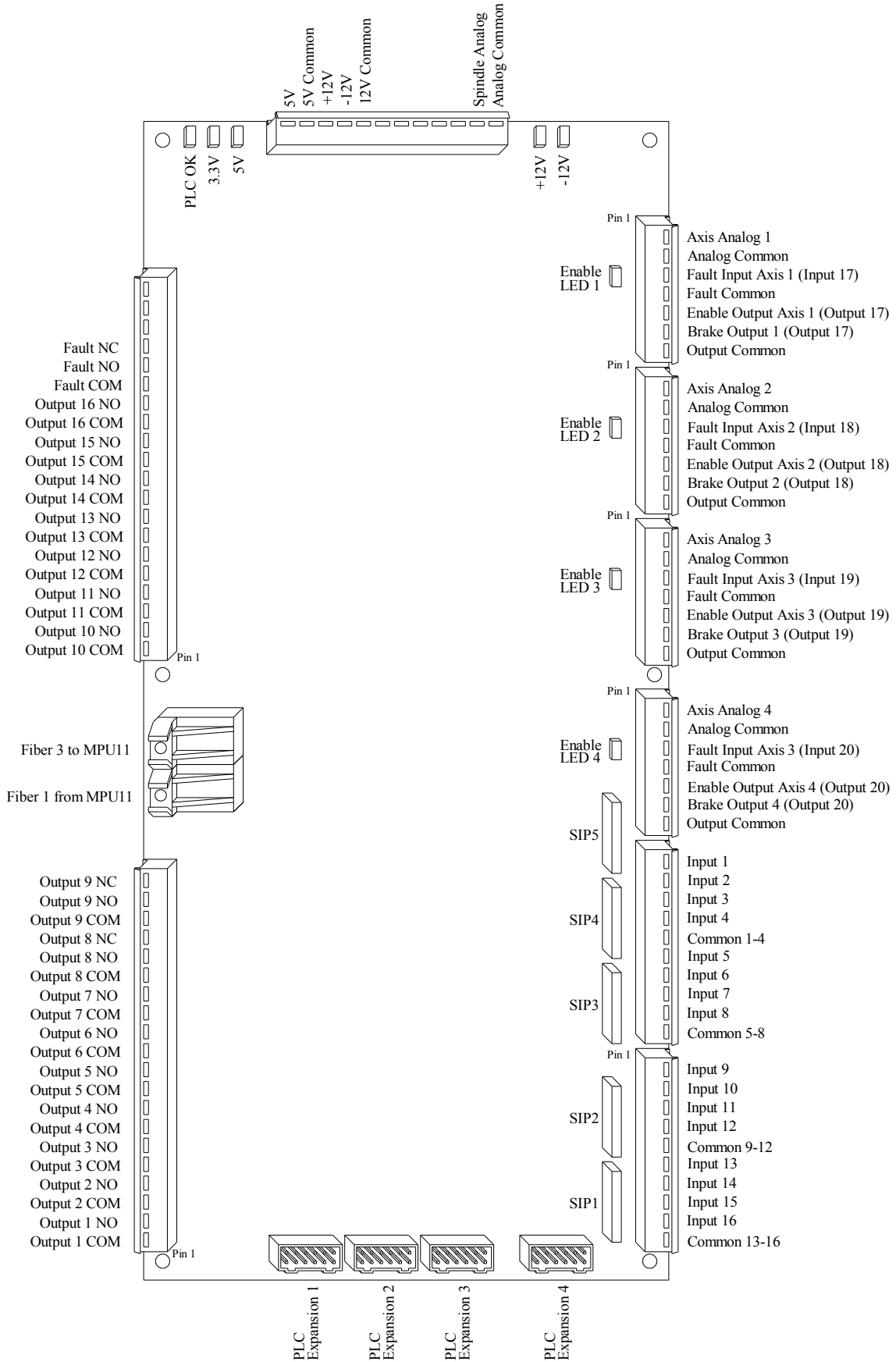

GPIO4D Mounting Dimensions

