



1332 MOD N-N6

Adjustable Min./ Max. Frequency

Description One option is available for use with a 0 – 10V input and one option is available for use with a 4 – 20mA input. When used with the specified input, this option provides an adjustable range for minimum frequency of 5% to 70% and Maximum frequency of 30% to 100%. A 15V DC power supply is included with this option.

Specifications

Input Power Source	Use $\pm 15V$ DC Power Source
Control Input	MOD N, N3, N5 - 0 to 10V DC, Input Impedance 100k Ohm MOD N2, N4, N6 - 4 to 20 mA DC, Input Impedance 380 Ohm
Control Output	Adjustable range of upper limit setting: Maximum 30% to 100% output voltage Adjustable range of lower limit setting: 0% to minimum 70% output voltage IMPORTANT: Zero voltage equals the minimum Drive frequency (3 Hz)
	<p>The left graph plots Output Voltage (0 to 10) against Input (0 to 10V/20mA). It shows two lines: one from (0,0) to (10,10) and another from (0,0) to (10,3). A vertical double-headed arrow between the 10 and 3 output levels is labeled 'MAX Potentiometer Adjustable Range'.</p> <p>The right graph plots Output Voltage (0 to 10) against Input (0 to 10V/20mA). It shows two lines: one from (0,0) to (10,10) and another from (0,0) to (10,7). A vertical double-headed arrow between the 10 and 7 output levels is labeled 'MIN Potentiometer Adjustable Range'.</p>
Ambient Temperature & Humidity	- 10°C to + 50°C, 5 to 95% non-condensing
Atmosphere	Indoor, No Corrosive Gas, Non-hazardous
Vibration Resistance	Minimum 0.5G

Specifications $\pm 15V$ DC Power Supply

Applicable Devices	Adjustable Minimum / Maximum Frequency & Preset Speeds Options
Input Voltage/Frequency	MOD N, N2 - 208/230V AC, 60 Hz MOD N3, N4 - 380/415/460V AC, 50/60 Hz MOD N5, N6 - 575V AC, 50/60 Hz
Permissible Input Voltage Variation	$\pm 10\%$
Output Voltage	Terminals 3(-) to 4(+): 15V DC @ 6 mA Terminals 5(-) to 6(+): 15V DC @ 20 mA
Ambient Temperature & Humidity	- 10°C to + 50°C, 5 to 95% non-condensing
Vibration Resistance	Minimum 0.5G

Installation

Install both the $\pm 15V$ DC Power Supply and the Adjustable Min. / Max. Frequency Option on a flat surface in an area not subjected to corrosive gasses or excessive temperatures (refer to specifications). Refer to the "Dimensions" and "Wiring" figures for further installation information.

Approximate Dimensions
Inches (mm)

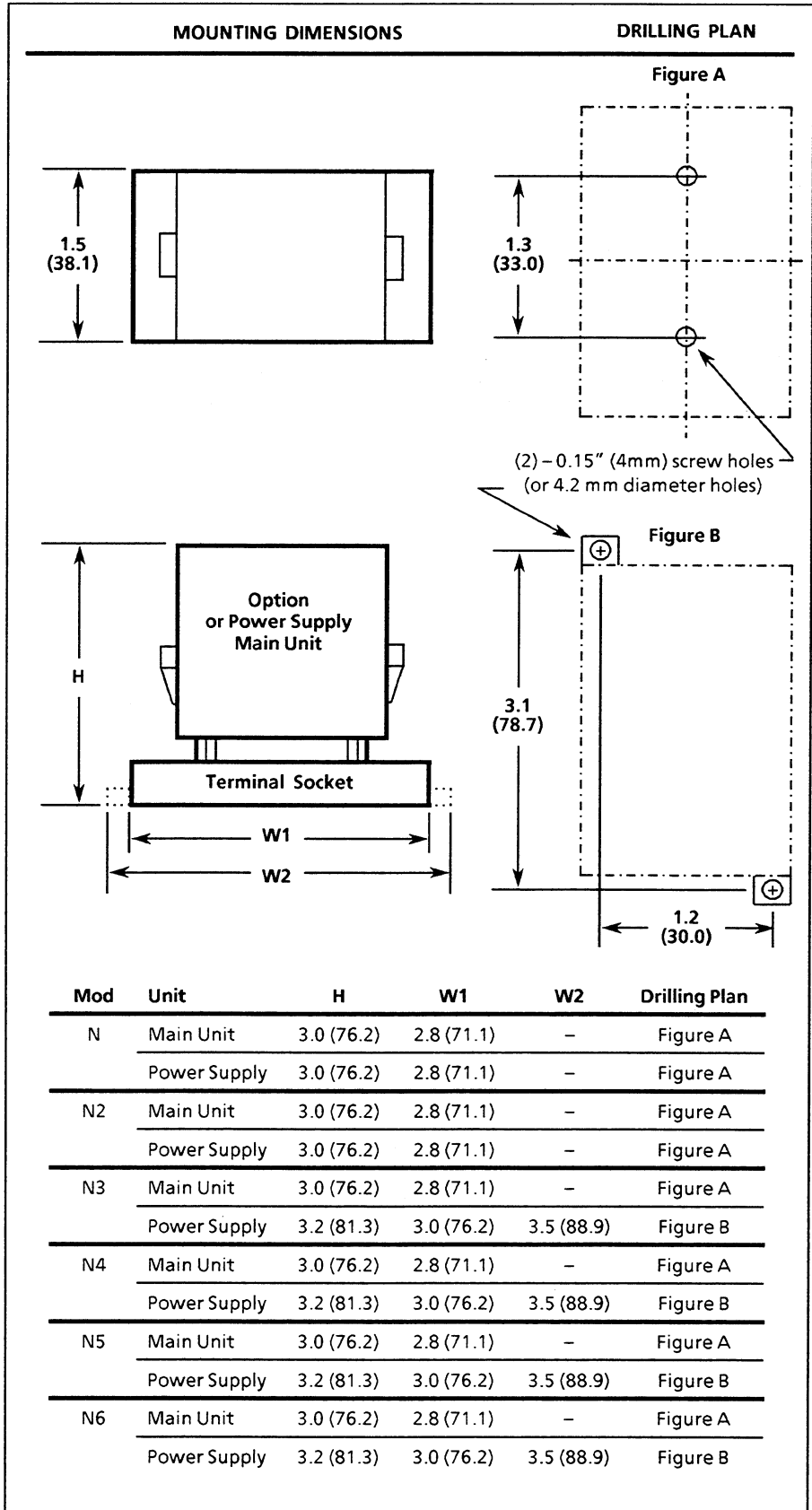

Socket Orientation

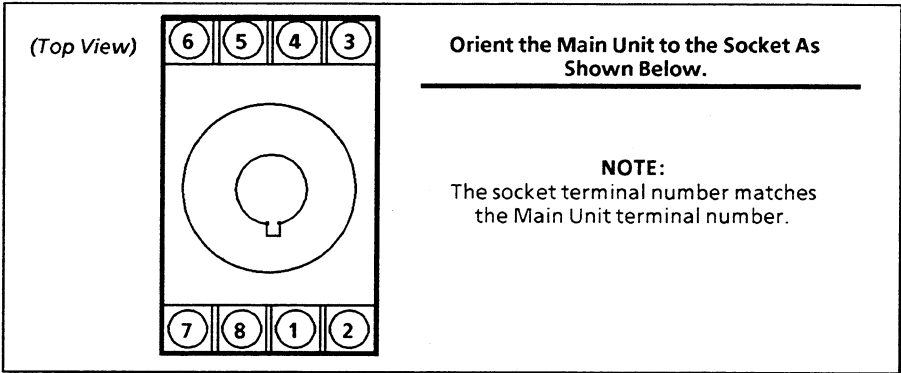

Wiring



WARNING: To avoid electrical shock hazard, REMOVE POWER before attempting to wire option.

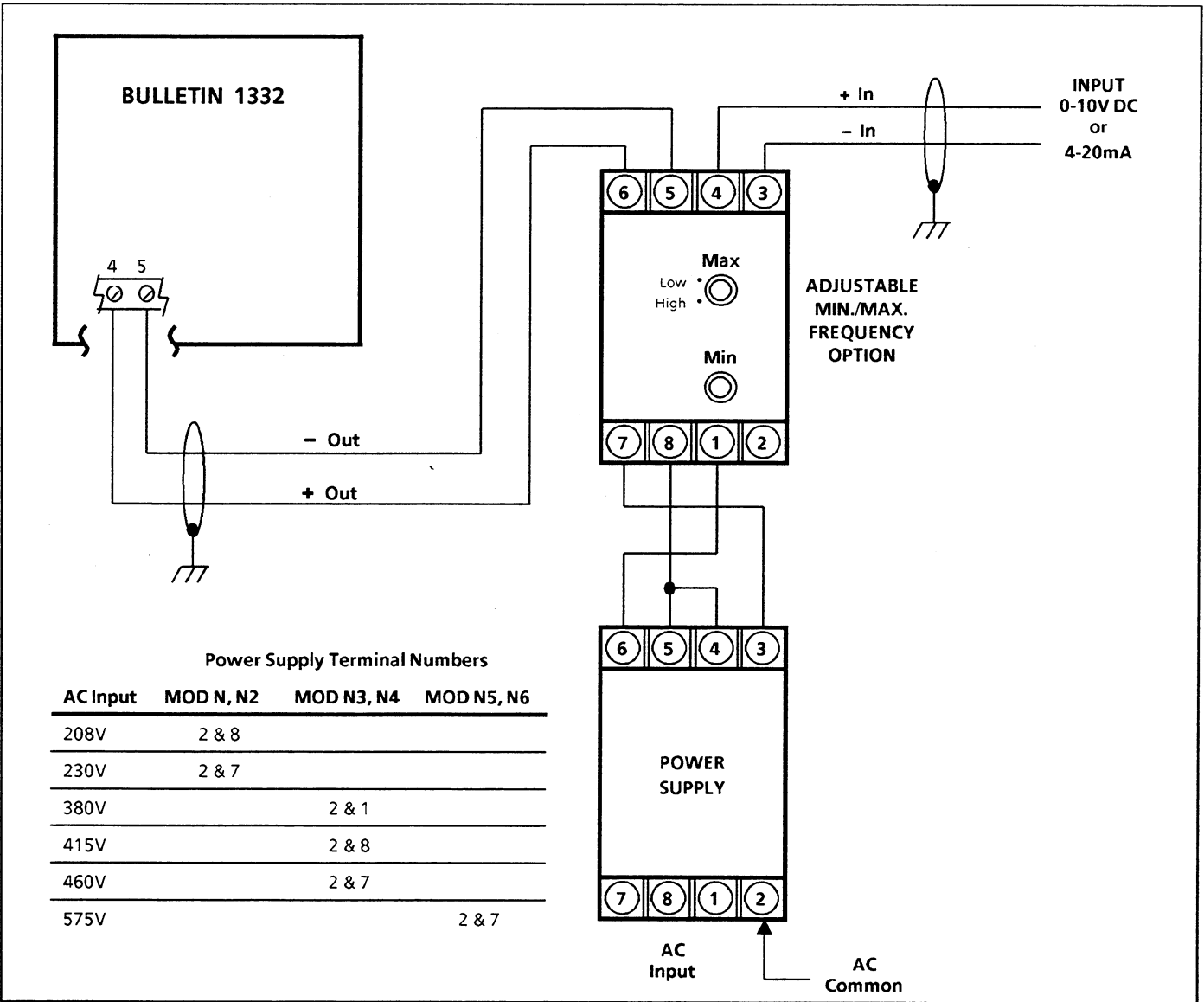

Wiring
(Continued)

The distance between the Adjustable Min. / Max Frequency option and the Drive must not exceed 10 feet (3 meters). It is recommended that shielded twisted pair cable be used for connections to terminals 5 and 6. The shield conductor is to be grounded at the Drive enclosure only, and the shield cut off and taped at the Option case. It is recommended that wiring connected to terminals 3 and 4 be shielded cable or twisted wires and no longer than 33 feet (10 meters). All control wiring **must** be located a minimum distance of 6 inches from any high voltage/current carrying conductors.

Set-Up and Adjustment

IMPORTANT: The Start-Up procedure for the Drive must be completed prior to Set-Up and Adjustment of this option.

1. **REMOVE DRIVE POWER.** Verify that switch SW4 is in the REMOTE position to accept an external input.
2. Turn the MAX pot clockwise to the HIGH position and MIN pot counterclockwise (CCW) to the LOW position.
3. Verify the connections of the option to the Drive. Refer to the "Wiring" section.
4. Apply Drive power and initiate a START. Apply 0V or 4 mA to the option as applicable.
5. Turn the MIN pot slowly clockwise (CW) until the local or remote frequency meter shows the minimum desired frequency. Verify frequency setting by the scale deflection of the meter indicator as it takes a certain amount of time for the Drive to follow the speed command.
6. Apply 10V or 20mA to the option as applicable.
7. Turn the MAX pot slowly counterclockwise (CCW) until the maximum desired frequency is achieved. Verify frequency setting by the scale deflection of the meter.
8. Set-up of this option is a dynamic adjustment procedure. Repeat steps 3 and 6 as necessary until optimum performance is achieved.
9. Initiate a STOP and **REMOVE DRIVE POWER.**



ALLEN-BRADLEY
A ROCKWELL INTERNATIONAL COMPANY

Drives Division
Cedarburg, Wisconsin 53012-0005