

PLC-Description

HEIDENHAIN TNC 151 B/TNC 151 Q HEIDENHAIN TNC 155 B/TNC 155 Q Contouring Control

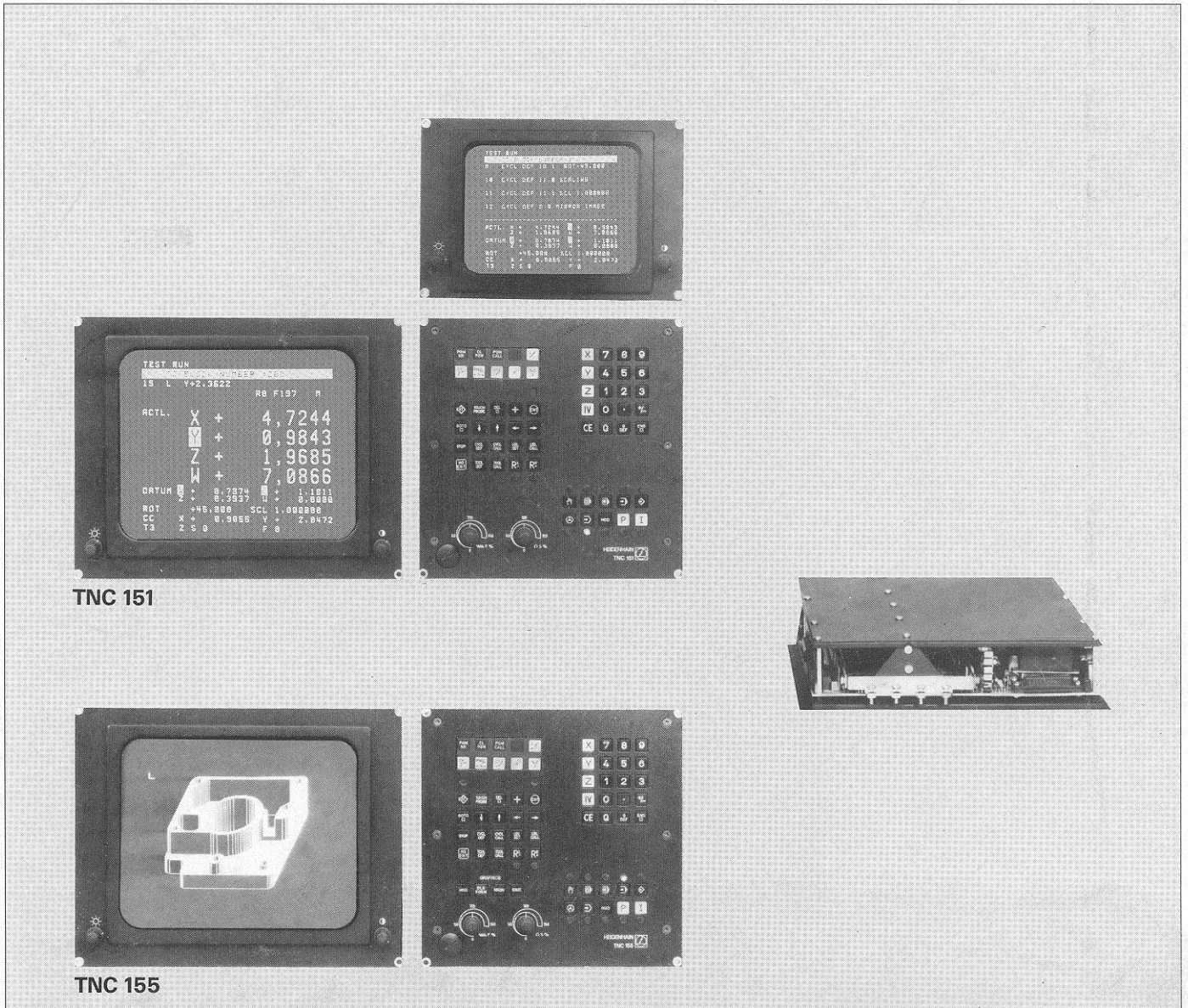

Contents	Section	Page
Introduction	A)	4
Connection and technical data	B)	5
Connection and technical data TNC 151 B/TNC 155 B	B 1)	6
Connection and technical data TNC 151 Q/TNC 155 Q	B 2)	7
Connection of TNC 151 Q/TNC 155 Q	B 2.1)	7
Grounding diagram	B 2.2)	8
Technical data for PLC	B 2.3)	9
Layout of inputs and outputs of PLC-boards	B 2.4)	12
PLC-boards PL 100 B/PL 110 B as first PLC-board	B 2.4.1)	12
PLC-boards PL 100 B/PL 110 B as second PLC-board	B 2.4.2)	13
EPROM for the PLC-Programme	B 3)	14
Programming of the HEIDENHAIN PLC	C)	15
Description of the PLC-Commands	C 1)	15
No Operation: NOP	C 1.1)	15
Assignment: =	C 1.2)	15
AND-Command: U	C 1.3)	16
AND-Command with inverted operand: UN	C 1.4)	16
OR-Command: O	C 1.5)	16
OR-Command with inverted operand: ON	C 1.6)	17
Exclusive OR-Command: XO	C 1.7)	17
Exclusive OR-Command with inverted operand: XON	C 1.8)	17
Programming of logic sequences	C 1.9)	18
Logic sequences with U-commands	C 1.9.1)	18
Logical sequences with UN-commands	C 1.9.2)	19
Logical sequences with O-commands	C 1.9.3)	20
Logic sequence with ON-commands	C 1.9.4)	21
Logic sequence with XO/XON commands	C 1.9.5)	22
Programming of an arbitrary logic sequence	C 1.9.6)	22
Setting and resetting of a marker	C 1.10)	23
Address allocation for PLC-markers	C 2)	24
User markers: Address letter M	C 2.1)	24
Markers for the signal exchanges between PLC and NC:		
Address letter M	C 2.2)	24
Markers for axes X, Y, Z, IV	C 2.2.1)	25
Release of axes	C 2.2.1.1)	26
Axes in position	C 2.2.1.2)	26
Inhibiting the Servo loop	C 2.2.1.3)	27
Transfer of actual position values as nominal values (Teach-in)	C 2.2.1.4)	28
Current tool-axis	C 2.2.1.5)	28
Traverse-dependent lubrication impulses	C 2.2.1.6)	29
PLC-Positioning	C 2.2.1.7)	30
Markers for M-S-T-Code-Outputs	C 2.2.2)	32
Coded M-S-T-Code Outputs	C 2.2.2.1)	32
Decoded M-Code output	C 2.2.2.2)	34
Transfer of machine parameter for rpm-limitation into the PLC-programme	C 2.2.2.3)	36
Markers for analogue output of the spindle speed	C 2.2.3)	36
Markers for the Vth axis for spindle orientation (option)	C 2.2.4)	38
Markers for the TNC-buttons	C 2.2.5)	39
Operating mode-code	C 2.2.5.1)	39
Decoded operating mode-code	C 2.2.5.2)	39
Currently activated axis button: X, Y, Z, IV	C 2.2.5.3)	39
Code for the external selection of TNC-buttons	C 2.2.5.4)	40
Markers for inhibiting buttons	C 2.2.5.5)	42
Markers for external buttons and switches	C 2.2.6)	44
Markers for ascending and descending edges of PLC-inputs	C 2.2.7)	45

	Section	Page
Markers for control status and error messages/User parameters	C 2.2.8)	46
Transfer of numerical values from the PLC to the NC	C 2.2.9)	50
Markers for touch probe system	C 2.2.10)	51
Macro-programs	C 2.2.11	52
Macro-programs for supporting a toolchanger with pocket coding	C 2.2.11.1)	52
Description of markers	C 2.2.11.1.1)	52
Machine parameter 209	C 2.2.11.1.2)	53
Mechanical design of toolchanger magazine and functioning	C 2.2.11.1.3)	54
Overview of markers for supporting a toolchanger	C 2.2.11.1.4)	56
Marker for switching from X, Y or Z axis to the 4th axis	C 2.2.12)	57
Markers for activating jog positioning	C 2.2.13)	58
Markers for setting axis sequence upon approaching the reference marks	C 2.2.14)	59
Further markers	C 2.2.15)	60
Markers for the first PLC-program cycle after power on and after interruption of PLC-program	C 2.2.15.1)	60
Markers affected by machine parameters	C 2.2.15.2)	62
Dialogue language selectable via machine parameter 92	C 2.2.15.3)	63
Release of user-cycles	C 2.2.15.4)	64
Marker for tapping cycle	C 2.2.15.5)	64
PLC-Inputs and PLC-outputs: Address letters E, A	C 2.3)	64
Overview	C 2.3.1)	65
Bipolar PLC-outputs for PL 110 B	C 2.3.2)	66
Output "Emergency Stop"	C 2.3.3)	66
Counters	C 3)	67
Timers	C 4)	68
Selecting and exiting from the PLC-modes	C 5)	69
"PLC Programme editor": PCE-button	C 5.1)	70
Keyboard layout for PLC-programming	C 5.1.1)	71
Button functions	C 5.1.2)	72
Programming PLC-commands	C 5.1.3)	73
Call-up of a specific PLC-command	C 5.1.4)	73
Sequential checking of PLC commands	C 5.1.5)	74
Deleting PLC-commands	C 5.1.6)	74
Entering PLC-commands into an existing programme	C 5.1.7)	74
Deleting a PLC-Program	C 5.1.8)	75
Transfer of a program from the main memory into the read/write-store	C 5.1.9)	75
Input/Output of PLC-programs on magnetic tape or printer	C 5.1.10)	76
Operating mode "PLC-Program trace function": PC-button	C 5.2)	78
Operating mode "Table E/A/Z/T/M": TAB-button	C 5.3)	79
Off-line PLC programming	C 6)	80
PLC-command format	C 6.1)	80
PLC-Operation codes for PLC-Commands	C 6.2)	80
PLC-Address for PLC-Commands	C 6.3)	80
Address allocation for PLC-EEPROM	C 6.4)	81
EEPROM Address list	C 6.5)	81
Standard PLC-program 23460102	D)	82
Address list	D 1)	82
Reference listing for markers, inputs/outputs and timers	D 2)	84
Standard PLC-program	D 3)	88
New functions as of PLC-software number 23460103	D 4)	102
Transfer of actual position values after opening of position loops	D 4.1)	102
Spindle orientation (V th axis)	D 4.2)	102
Summary of new functions as of PLC-software number 23460103	D 4.3)	102
Terminal layout for input/output signals for TNC	D 5)	103
Programming list	E)	104
List of machine parameters	F)	110
List of markers for signal exchange between PLC and NC	G)	119

This PLC-description is valid for all TNC 151/TNC 155-versions:

Transducer inputs	TNC 151/TNC 155-versions without separate PLC-board(s)	TNC 151/TNC 155-versions with PLC-board(s)
Sinusoidal signals	TNC 151 B/TNC 155 B TNC 151 F/TNC 155 F**	TNC 151 Q/TNC 155 Q TNC 151 W/TNC 155 W**
Squarewave signals	TNC 151 BR/TNC 155 BR TNC 151 FR/TNC 155 FR**	TNC 151 QR/TNC 155 QR TNC 151 WR/TNC 155 WR**

**without 3D-movement and "Transfer blockwise"

We are constantly working on the further development of our TNC-Controls and a certain control may deviate from the versions described within this manual.

A) Introduction

Logic circuits operate in binary i.e. two unique, dedicated switching states.

The two possible logic states will be represented by the figures "1" and "0" in this description.

Example:

Switch closed = "1"

Switch open = "0"

Lamp on = "1"

Lamp off = "0"



This relationship can be represented with the aid of a function table (truth table). The switch state is represented as an input variable (operand) E 1 and the lighted lamp as a logic result A 1.

Truth Table:

E 1	A 1
0	0
1	1

Digital switching signals can be combined (logic circuits). The basic logic elements in the switching algebra are:

- AND
- OR
- NOT

The logic results of digital switching signals can be realised in the following ways:

- .through relays
- .through integrated circuits
- .through software programmes.

Since the implementation of logic sequences using software programmes allows greater flexibility in the event of alterations, the programmable interface (PLC = Programmable Logic Controller) has gained ground in the application to machine tool control.

The PLC is integrated in the HEIDENHAIN control TNC 151/TNC 155, giving the following advantages:

- .The signals between NC and PLC are markers, making more input and output signals possible and the control more flexible
- .The hardware interface is simplified
- .As the PLC program can be entered at the control, an external programming station is unnecessary
- .When programming the PLC functions, an immediate check is possible
- .Machine faults can be displayed on the screen.

B) Connection and technical data

The HEIDENHAIN TNC 151/TNC 155 control is available in two basic versions:

TNC 151 B/TNC 155 B with interface for external machine adaptation

TNC 151 Q/TNC 155 Q with external PLC-power boards PL 100 B or PL 110 B

Technical data for controls TNC 151 B/TNC 151 Q, TNC 155 B/TNC 155 Q

Mains voltage supply	Selectable 100/120/140/200/220/240 V + 10 % / - 15 %, 48 ... 62 Hz If the permissible tolerances of the mains voltage cannot be kept, we recommend the voltage regulator, type "Volkraft" from Messrs. Conrad Electronic. The voltage regulator can also be supplied by your local HEIDENHAIN service centre.
Power consumption	TNC 151 B/TNC 151 Q ca. 60 W (with 9" VDU-screen BE 111 or 12" VDU-screen BE 211) TNC 155 B/TNC 155 Q Logic and control unit ca. 45 W 12" VDU-screen BE 411 ca. 40 W
	Current consumption of PLC-boards PL 100 B/PL 110 B First board: 460 mA \pm 25 mA (all inputs and outputs open, second board not connected) Second board: 360 mA \pm 25 mA
Ambient temperature	Operation 0 ... + 45° C (+ 32 ... + 113° F) Storage - 30 ... + 70° C (- 22 ... + 158° F)
Weight	Control TNC 151 B/TNC 151 Q: 12 kg Control TNC 155 B/TNC 155 Q: 12 kg 9" VDU-screen BE 111: 6.8 kg 12" VDU-screen BE 211: 10 kg 12" VDU-screen BE 411: 10 kg PLC-boards PL 100 B/PL 110 B: 1.2 kg

Please note:

All inputs and outputs of the controls may only be connected to circuits having protective low voltage.

B 1) Connection and technical data TNC 151 B/TNC 155 B

TNC 151 B/TNC 155 B is adapted to the machine externally.

The interface of the function via an internal PLC-program (see section D 3). This program may, if required, be subjected to slight alterations by the machine tool manufacturer.

With TNC 151 B/TNC 155 B only the

inputs E0 – E23

and

outputs A0 – A22

are used and extended externally via connectors J1 – J6 (see section D)

Technical data for control inputs

Potential-free opto-couplers (switched into groups)

Operating voltage max. 30 V –, filtered

Optocouplers switched through $\cong 15$ V

Optocouplers open $\cong 8$ V

Loading per input < 10 mA

Technical data of control outputs

Potential-free relay contacts (switched into groups)

Operating voltage max. 30 V –/min. 15 V –

Operating current per contact max. 50 mA

Permissible load Resistive load;

inductive load only with quenching diode parallel to inductivity.

To prevent welding of contacts during a short circuit, a current limiting resistor of 47 ohms is switched into series with each contact.

Detailed information concerning the connection and adaptation is available in the special interfacing manual.

B 2) Connection and technical data of TNC 151 Q/TNC 155 Q

B 2.1) Connection of TNC 151 Q/TNC 155 Q

With TNC 151 Q/TNC 155 Q a clear and simple arrangement of the control-adaptation system is possible. Due to loss of power the inputs and outputs of the PLC have been accommodated on one (or two) boards which are separated from the TNC-unit.

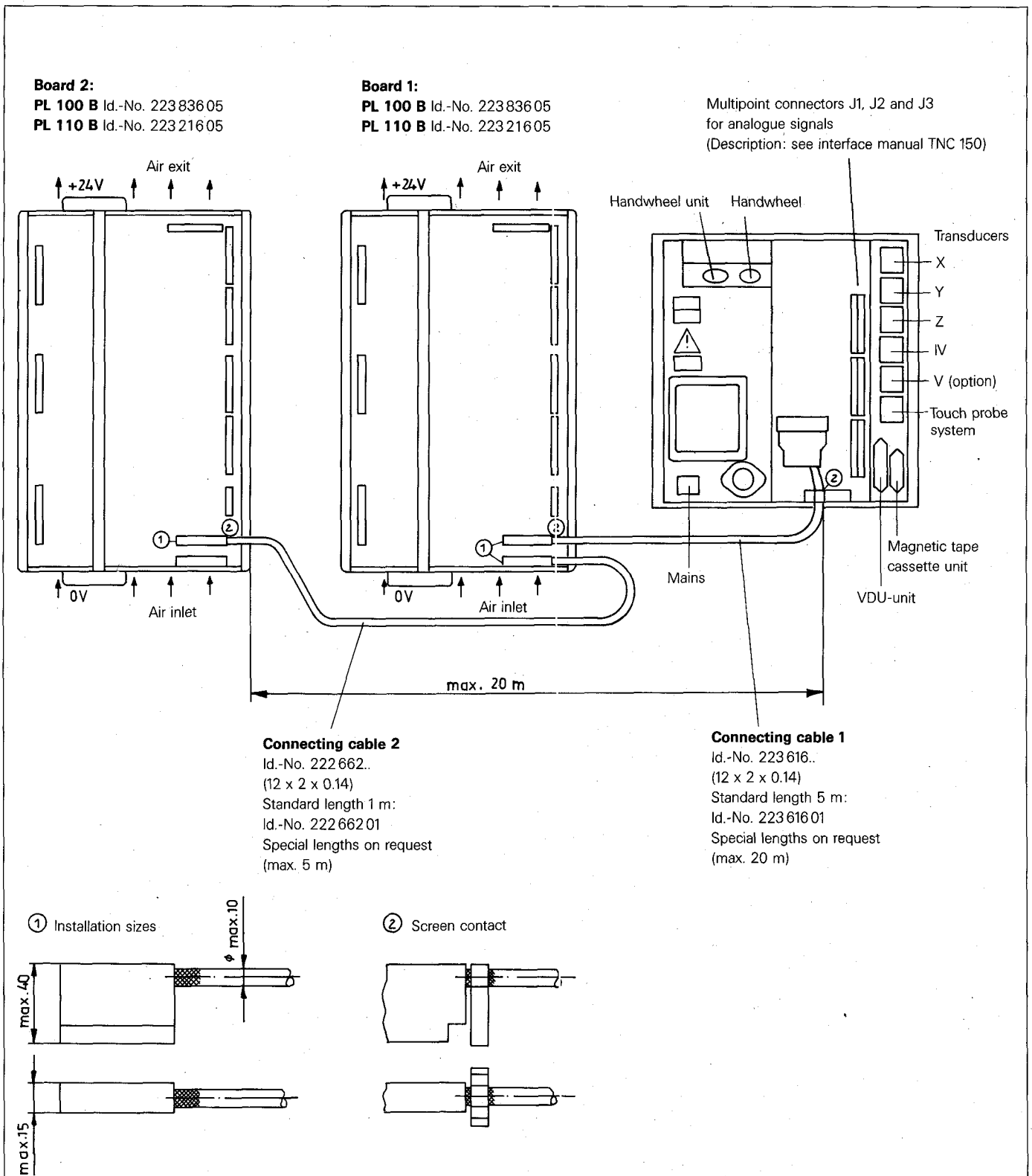

Please note:

The total length of cable between TNC and Board 2 must not exceed 20 m.

The cable length between Board 1 and Board 2 must not exceed 5 m.

B 2.2) Grounding diagram

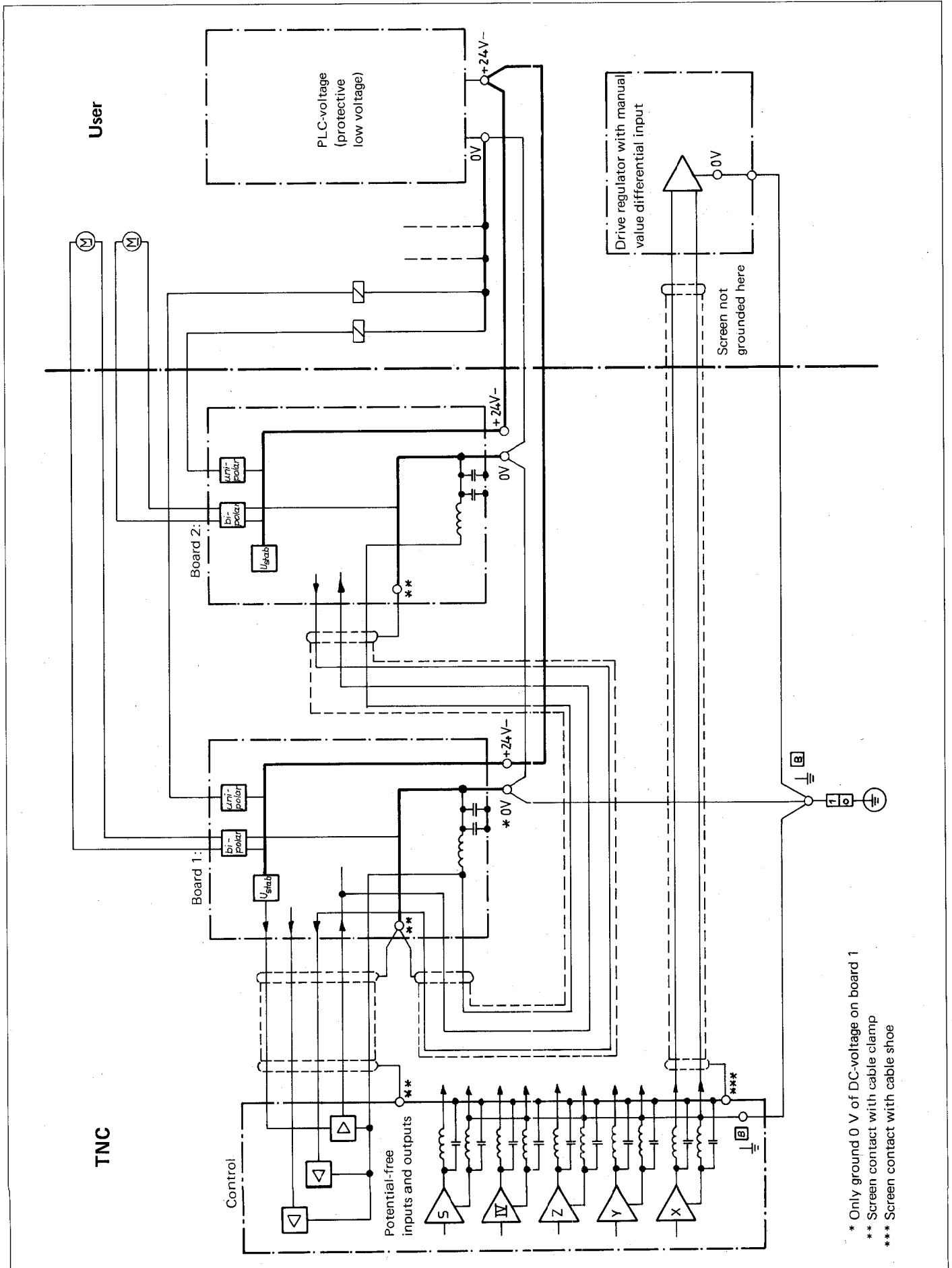

* Only ground 0 V of DC-voltage on board 1
 ** Screen contact with cable clamp
 *** Screen contact with cable shoe

B 2.3) Technical data for PLC

The HEIDENHAIN-PLC offers the following hardware:

The figures in brackets apply to the second input/output board

	Abbreviation	Remarks
1000 User Markers – not power fail protected	M	Marker = 1 bit memory User Marker is a marker freely available for PLC-programming
1000 User Markers – power fail protected	M	
1024 Designated Markers	M	Designated Marker is a marker allocated for data transfer between the TNC and PLC
16 Counters	Z	For counting function in PLC programme
32 Timers	T	For timing function in PLC programme
PL 100 B		
64 (+64) Inputs	E	9 Inputs are designated for TNC input signals (only with Board 1) 1 Input per PCB is internally wired
32 (+32) Outputs	A	1 Output per PCB is internally wired
1 (+1) Output "Emergency Stop"		Internal "Emergency Stop" wired from the NC section of the control directly to the output
PL 110 B		
64 (+64) Inputs	E	9 Inputs are designated for TNC input signals (only with Board 1) 1 Input per PCB is internally wired
26 (+26) Outputs	A	1 Output per PCB is internally wired
3 (+3) Bipolar Output Pairs	A	For control of D.C. motors
1 (+1) Output "Emergency Stop"		Internal "Emergency Stop" wired from the NC section of the control directly to the output
1 (+1) Output "Current supervision"		For the monitoring of the bipolar outputs

The PLC program will – irrespective of the program length – cycle through every 20 ms, thus the inputs will be interrogated once every 20 ms, outputs can change once every 20 ms.

Nominal values and tolerances

External voltage supply for PLC

Nominal voltage: 24 V, –
Voltage range: 20.4 V to 28.8 V

Furthermore, superimposed AC-voltages having a relative oscillation width of 10 % with respect to the DC voltage average are permitted.

Circuitry example:

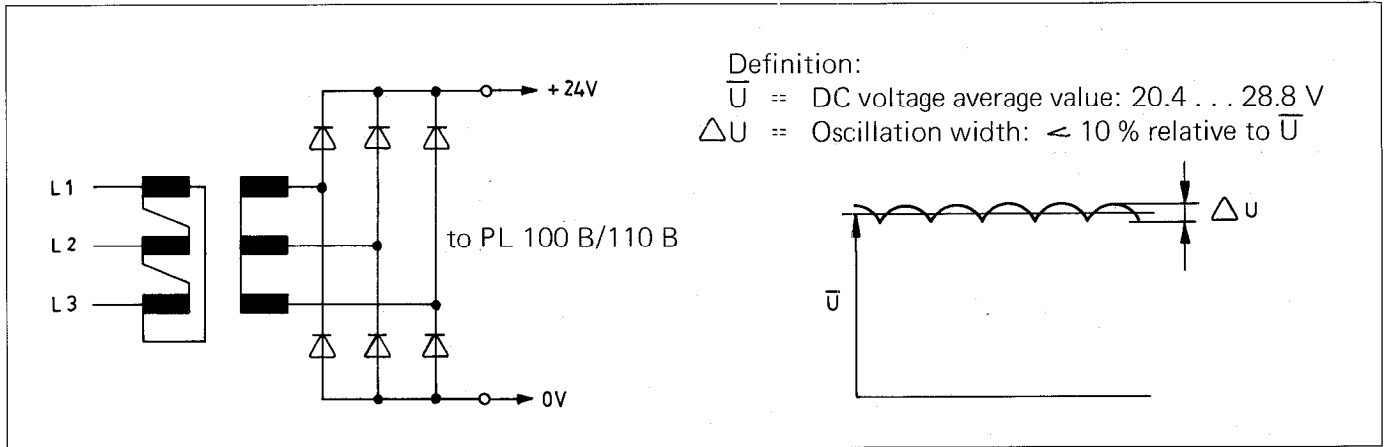

Binary input signals (E0 to E62 and E64 to E126)

Nominal voltage: 24 V, –
Voltage range for signal "1": 16.5 V to 30 V
Voltage range for signal "0": –3 V to +4 V
Current range for signal "1": 6.2 mA to 12.6 mA

Please note:

Interference signals < 1 ms at the PLC-outputs are filtered via a lowpass Schmitt-Trigger input circuit. Interference signals which are of longer duration must be filtered out by the software.

Binary output signals (PL 100B: A0 to A30, A32 to A62; PL 110 B: A0 to A24, A32 to A56 and "Emergency stop")

Nominal voltage: 24 V, –
Max. voltage difference to supply voltage: < 3 V
Max. output current: 1.2 A
Permissible loading: Resistive load: inductive load only with quenching diode parallel to inductivity.
Max. circuit frequency: 50 Hz

Please note:

Adjacent PLC-Outputs (e.g. A7 with A8) can be switched parallel via resistors (e.g. $2 \times 0,47 \Omega$).

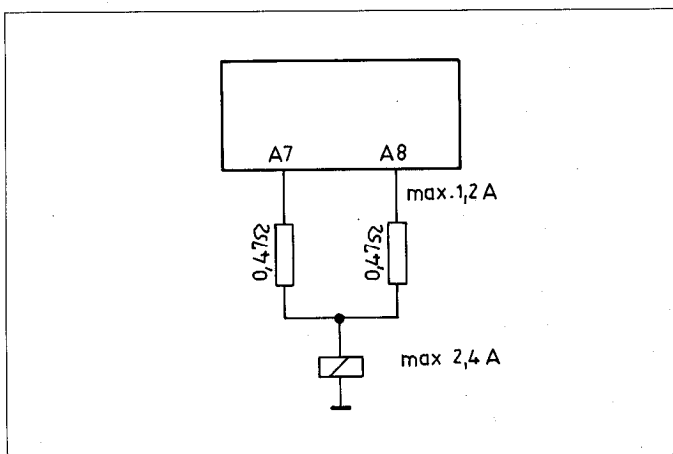

Bipolar outputs (PL 110 B: A25 to A30 and A57 to A62)

Nominal voltage: 15 V, –

(Measured between to bipolar outputs whereby one output is switched to signal "1" and the other to signal "0")

Nominal current: 300 mA

Voltage range with nominal current: 14.0 V to 15.5 V)

Max. output current 1.2 A for 1 minute

Range for current limitation: 1.35 A to 1.6 A

Permissible loading: Resistive inductive load only with queching diode parallel to inductivity.

Max. circuit frequency: 50 Hz

Please note:

Bipolar PLC-outputs may not be switched parallel.

Use of bipolar outputs as binary output signals:

Voltage for signal "1": ≥ 14.2 V

Voltage for signal "0": ≤ 3.0 V

Nominal current: 300 mA

Max. output current 1.2 A for 1 minute

Output for current monitoring

Monitoring of output currents of all bipolar outputs. The output J3/11 supplies signal "1" if the sum of the output currents of all bipolar outputs ≥ 0.8 A to 0.9 A.

Nominal voltage: 24 V, –

Max. output current: 55 mA to 65 mA

Max. voltage difference to supply voltage: ≤ 1.5 V

B 2.4) Layout of inputs and outputs of PLC-boards

All inputs and outputs may only be connected to circuits with protective low voltage.

B 2.4.1) PLC-board PL 100 B / PL 110 B as first PLC-board

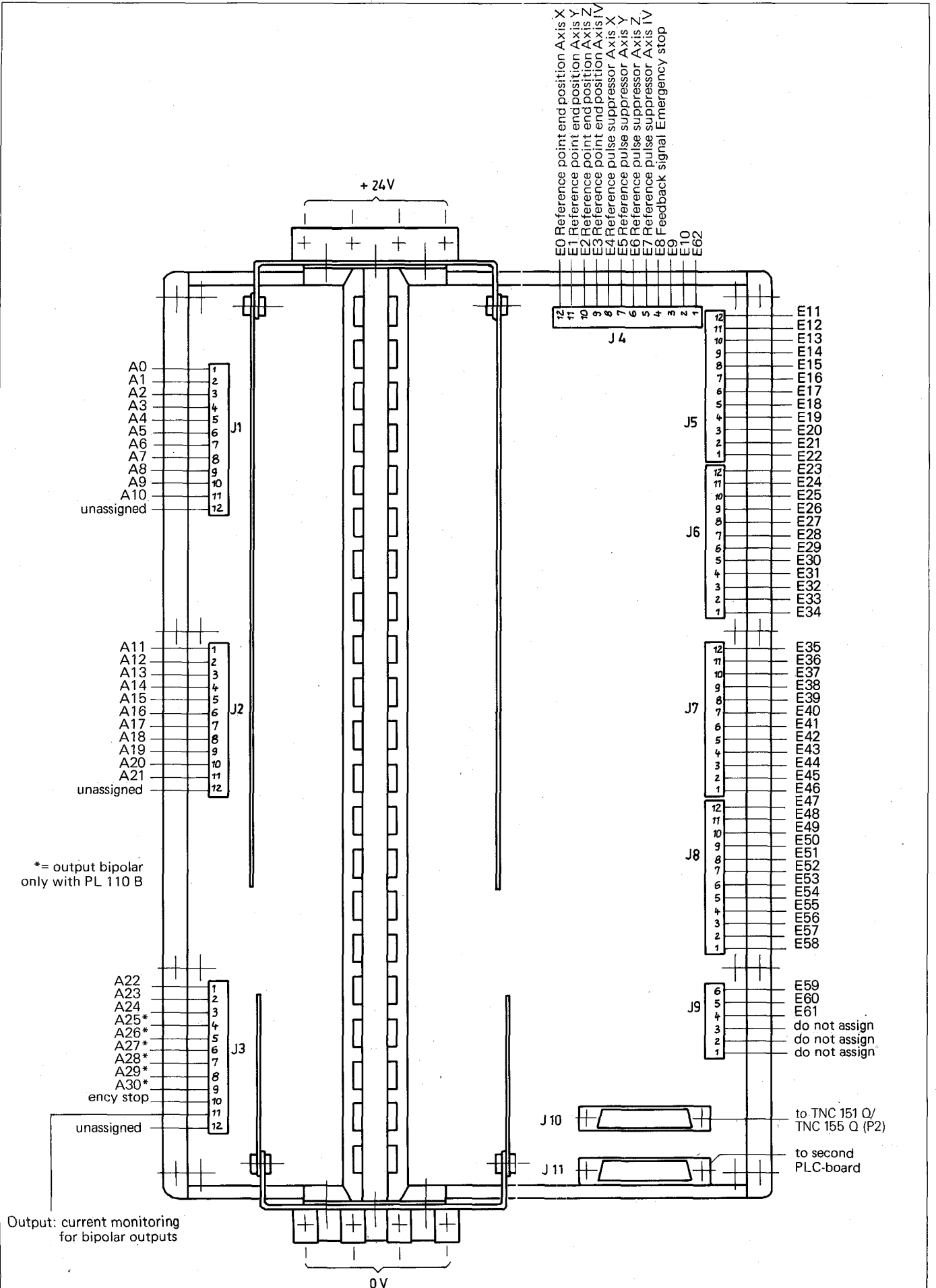

B 2.4.2) PLC-board PL 100 B / PL 110 B as second PLC-board

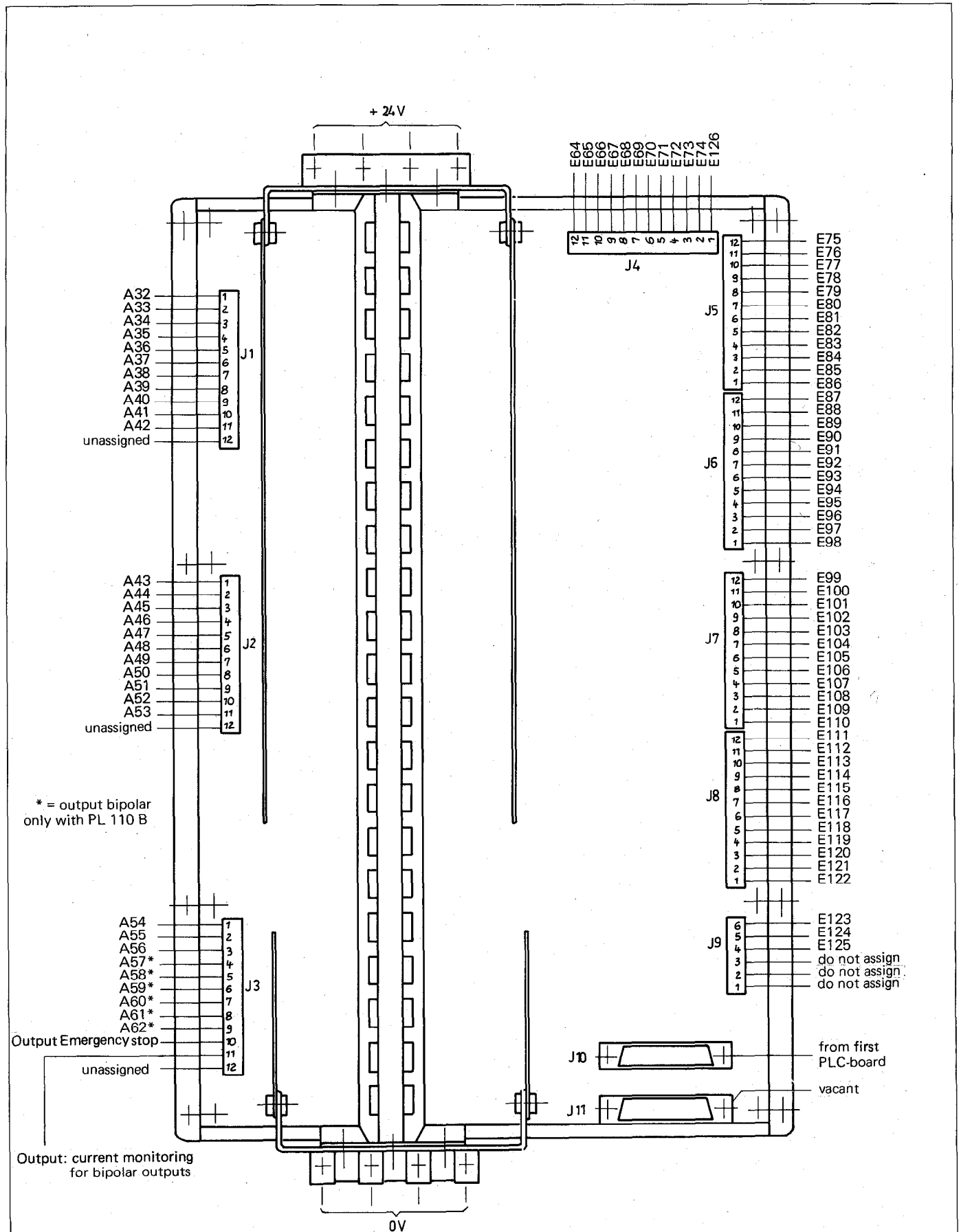

B 3) EPROM for the PLC-Program

The PLC-program, together with the internal PLC-software and the PLC-dialogue text, is permanently stored in an EPROM type HN 27512 (see section C 7.4 for address allocation).

The EPROM is located in the TNC-unit on the **first plug-in PCB from the front** – counting from the first panel. It carries the identification 6 . . (the points represent arbitrary numbers and letters).

Please note:

The PLC-software number is displayed in the "MOD"-mode (please refer to the Operating Manual).

The plug-in location can be taken from the sketch below.

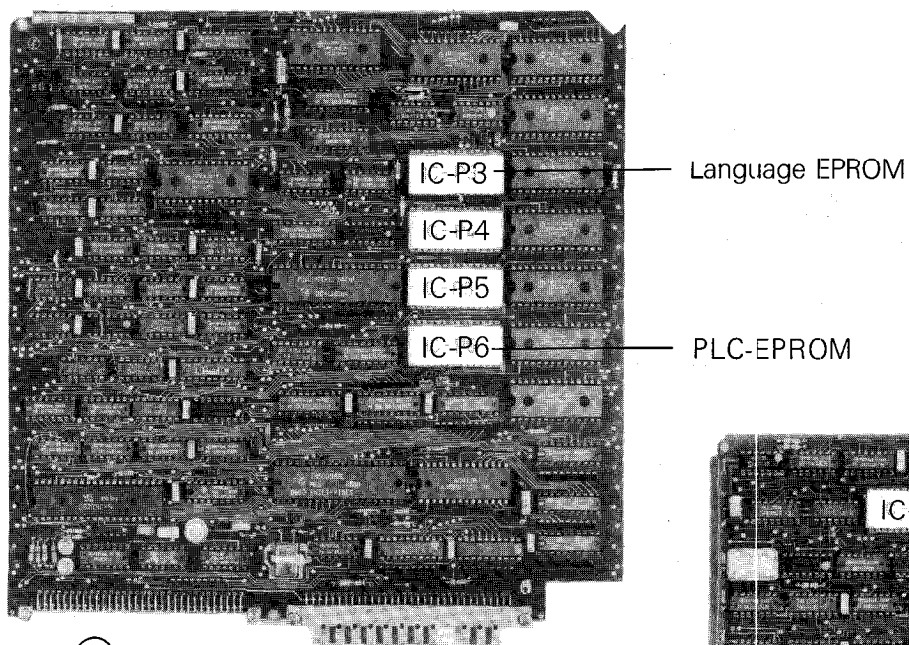

①

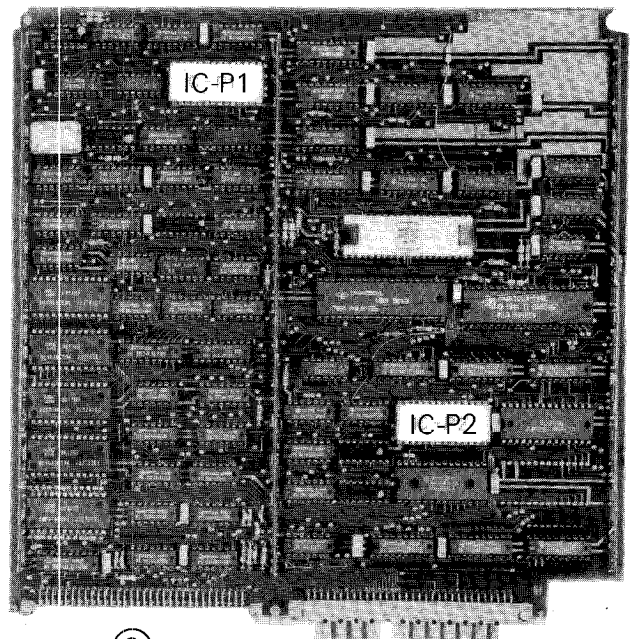

②

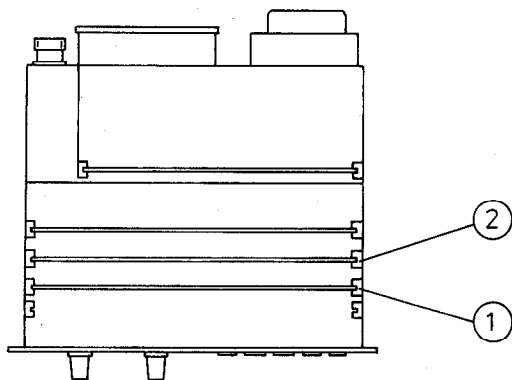

Please note:

Customer-specific PLC-programs can be entered into the control before delivery ex-works. If HEIDENHAIN is not informed of the customer-specific PLC-program, the control is supplied with the standard PLC-program. More detailed information is available from your nearest HEIDENHAIN sales office.

C) Programming of the HEIDENHAIN PLC

C 1) Description of the PLC Commands

It is convenient to represent the integrated PLC in the HEIDENHAIN control as relays or various logic circuits. These comprise commands that the binary operations (logic gates) execute.

A PLC-program can consist of up to **2048 commands**. Each individual logic command combines two input values, of which the first is the result of the previous logic gate and the second is self-addressed with the logic command. Gates with inputs are possible using a series string of multiple commands.

The following commands are programmable:

Command	Abbreviation
No Operation	NO ^P
Assignment	=
AND	U
AND with negative operand (NAND)	UN
OR	O
OR with negative operand (NOR)	ON
EXCLUSIVE OR	XO
EXCLUSIVE OR with negative operand (EXCLUSIVE NOR)	XON
Set memory or output if result of previous logic gate is logic "1"	S
Set memory or output if result of previous logic gate is logic "0"	SN
Reset memory or output if result of previous logic gate is "1"	R
Reset memory or output if result of previous logic gate is "0"	RN

C 1.1) No Operation: NOP

No Operation designates an empty memory location in the command memory.

Every memory location in the command memory which is not occupied by another command, functions as a NOP-command.

Command	Abbreviation
No operation	NOP

C 1.2) Assignment: =

The preceding logic circuit is assigned to a marker or output: a logic sequence is interrupted.

Command	Abbreviation	PLC-Programme
Assignment	=	U E1 U E2 = M30

C 1.3) AND-Command: U

With the aid of the U-command, two input variables can be gated according to the logical AND-function.

The first input variable is either:

the logic result of an immediately preceding gating operation (U, UN, O, ON, XO, XON)

or

logic "1" in the event of an immediately preceding operation being R, RN, S, SN or =.

The second input variable is self-addressed with the U-command.

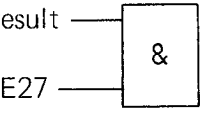
Command	Abbreviation	Symbol	PLC-Programme
AND	U	Preceding result — 	U E27

C 1.4) AND-Command with inverted operand: UN

With the aid of the UN-command, two input variables can be gated according to the logical AND-function.

The first input variable is either:

the logic result of an immediately preceding gating operation (U, UN, O, ON, XO, XON)

or

logic "1" in the event of an immediately preceding operation being R, RN, S, SN or =.

The second input variable is self-addressed with the UN-command and **inverted**.

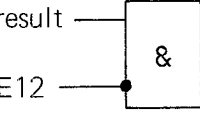
Command	Abbreviation	Symbol	PLC-Programme
AND with inverted operand	UN	Preceding result — 	UN E12

C 1.5) OR-Command: O

With the aid of the O-command, two input variables can be gated according to the logical OR-function.

The first input variable is either:

the logic result of an immediately preceding gating operation (U, UN, O, ON, XO, XON)

or

logic "0" in the event of an immediately preceding operation being R, RN, S, SN or =.

The second input variable is self-addressed with the O-command.

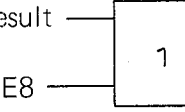
Command	Abbreviation	Symbol	PLC-Programme
OR	O	Preceding result — 	O E8

C 1.6) OR-Command with inverted operand: ON

With the aid of the ON-command, two input variables can be gated accordingly to the logical OR-function.

The first input variable is

either

the logic result of an immediately preceding gating operation (U, UN, O, ON, XO, XON)

or

logic "0" in the event of an immediately preceding operation being R, RN, S, SN or =.

The second input variable is self-addressed with the ON-command and **inverted**.

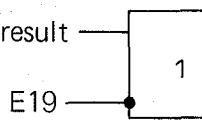
Command	Abbreviation	Symbol	PLC-Programme
OR with inverted operand	ON		ON E19

C 1.7) Exclusive OR-Command: XO

With the aid of the XO-command, two input variables can be gated according to the logical Exclusive OR-function.

The first input variable is

either

the logic result of an immediately preceding gating operation (U, UN, O, ON, XO, XON)

or

logic "0" in the event of an immediately preceding operation being R, RN, S, SN or =.

The second input variable is self-addressed with the XO-command.

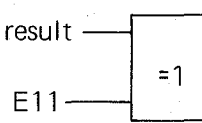
Command	Abbreviation	Symbol	PLC-Programme
Exclusive-OR	XO		XO E11

Note:

An Exclusive OR function generates a logic "1" at the output, when **only one** input is set to logic "1". If both inputs are logic "1" or logic "0", the output generates a logic "0".

C 1.8) Exclusive OR-command with inverted operand: XON

With the aid of the XON-command, two input variables can be gated according to the logical Exclusive NOR-function.

The first input variable is

either

the logic result of an immediately preceding gating operation (U, UN, O, ON, XO, XON)

or

logic "0", in the event of an immediately preceding operation being R, RN, S, SN or =.

The second input variable is self-addressed with the XON-command and **inverted**.

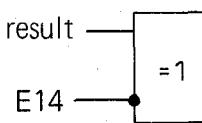
Command	Abbreviation	Symbol	PLC-Programme
Exclusive OR command with inverted operand	XON		XON E14

C 1.9) Programming of logic sequences

The logic-commands of the PLC can be arranged in chains to form a logic sequence.

Logic sequences are interrupted by the PLC-commands: R, RN, S, SN or =; a new logic sequence begins after these commands.

C 1.9.1) Logic sequences with U-commands

A logic sequence with U-commands effects a series switching of contacts. These contacts are normally open. This corresponds to an AND-gate.

PLC-Program	Gating-logic	Abbreviated Symbol	Truth table			Contact example
			E1	E2	A1	
U E1 U E2 = A1			0 0 1 1	0 1 0 1	0 0 0 1	

Examples:

a)

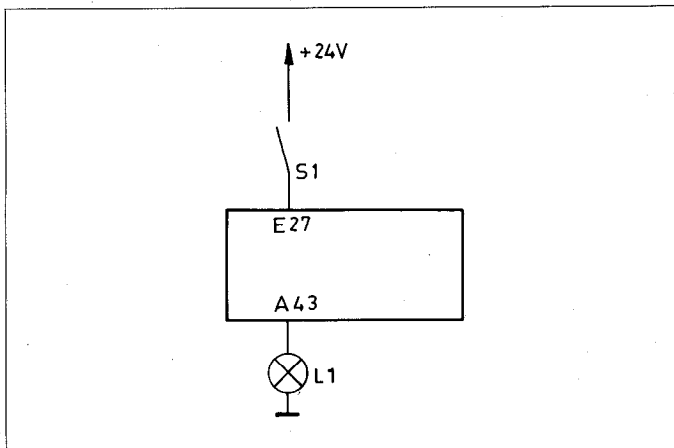

The lamp L1 is connected to the output 43. The closing of the contacts S1 should result in the illumination of the lamp. The contacts are connected to input E27 of the PLC.

PLC-Program: U E27
= A43

This PLC-program effects the following switching:

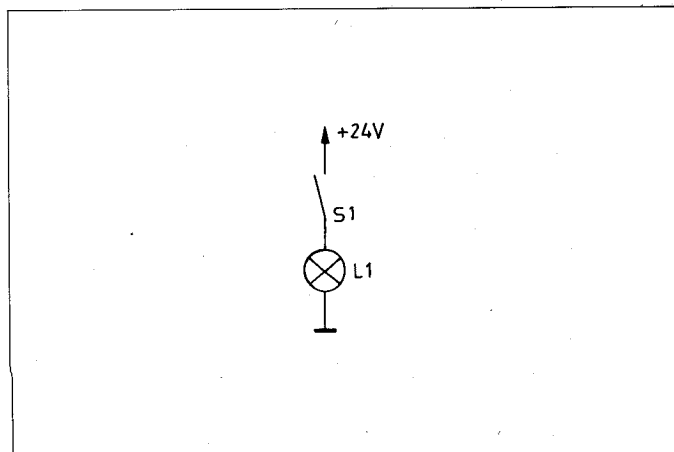

b)

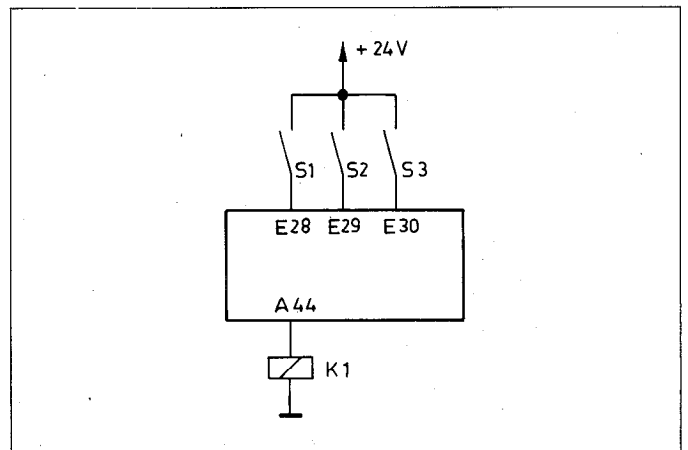

The relay K1 should energise, in the event of the contacts S1, S2 and S3 closing simultaneously.

PLC-Program: U E28
U E29
U E30
= A44

The PLC-program effects a series switching of the contacts S1, S2 and S3:

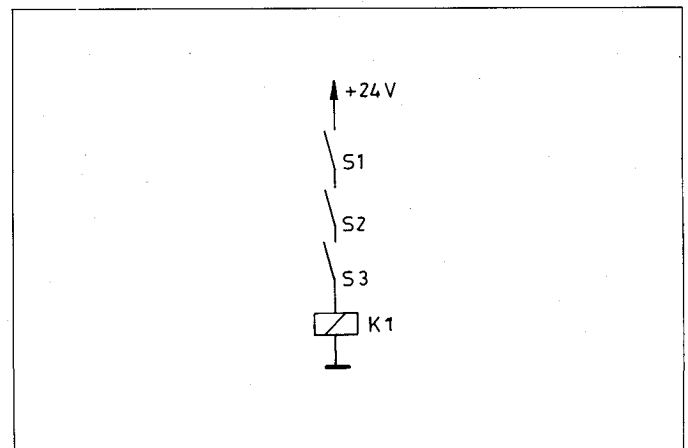

C 1.9.2) Logical sequences with UN-commands

A logical sequence with UN-commands effects a series switching of contacts. These contacts are normally closed. This corresponds to an AND gate with inverted operands.

PLC-Program	Gating-logic	Abbreviated symbol	Truth table			Contact example
			E1	E2	A1	
UN E1 UN E2 = A1			0	0	1	
			0	1	0	
			1	0	0	
			1	1	0	

It can be deduced from the truth table that this logic element is behaving as a NOR-function. This also follows the mathematical rules governing Boolean algebra:

$$\overline{E1} \cdot \overline{E2} = \overline{E1 + E2}$$

Examples:

a)

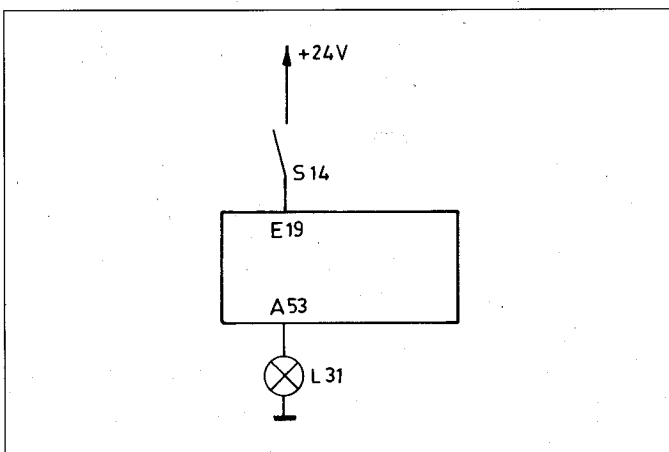

The lamp L31 should illuminate when the contact S14 is opened.

PLC-Program: UN E19
= A53

This PLC-program effects the following switching:

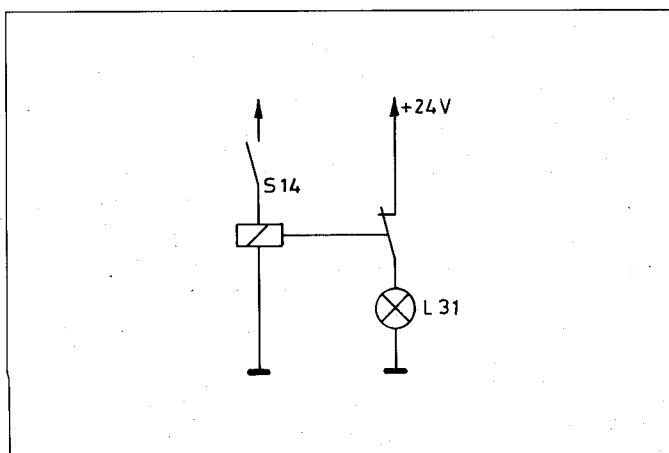

b)

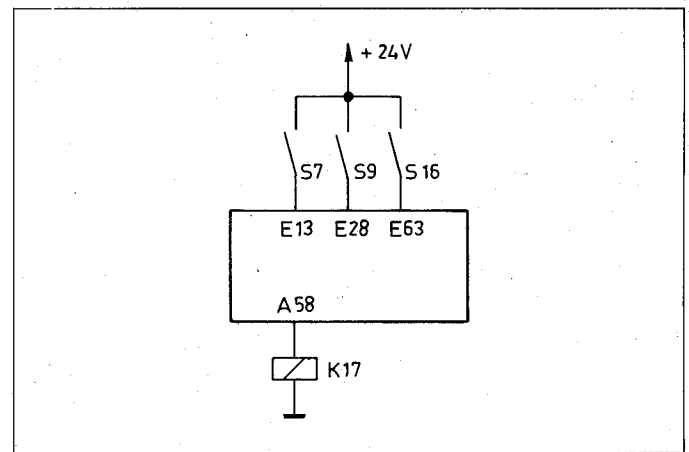

The relay K17 should only energise when all three contacts S7, S9 and S16 are open.

PLC-Program: UN E13
UN E28
UN E63
= A58

This PLC-program effects the following switching:

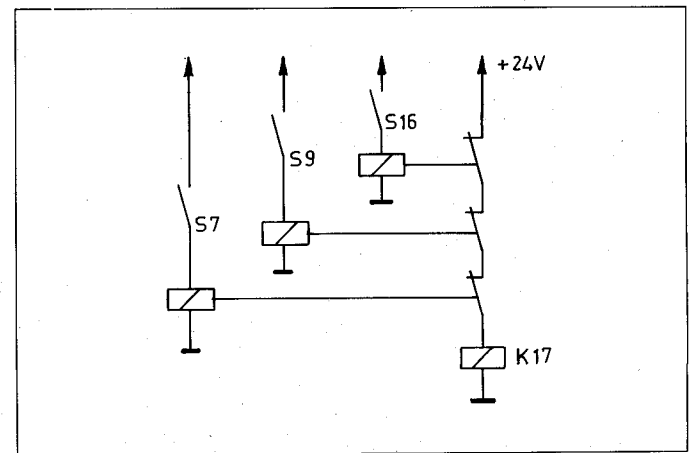

C 1.9.3) Logic sequences with O-commands

A logic sequence with O-commands effects a parallel switching of contacts. The contacts are normally open. This corresponds to an OR-gate.

PLC-Program	Gating logic	Abbreviated symbol	Truth table			Contact example
			E1	E2	A1	
O E1 O E2 = A1			0 0 0 0 1 1 1 0 1 1 1 1			

Examples:

a)

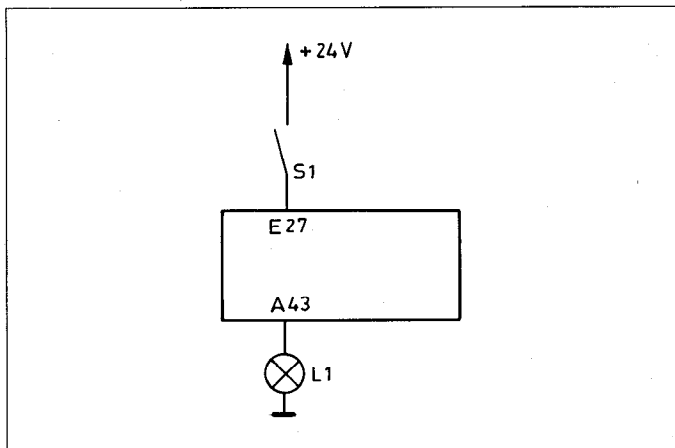

Lamp L1 is connected to output 43.
 The closing of contact S1 illuminates the lamp.
 The contact is connected to input E27 of the PLC

PLC-Program: O E27
 = A43

This PLC-program effects the following switching:

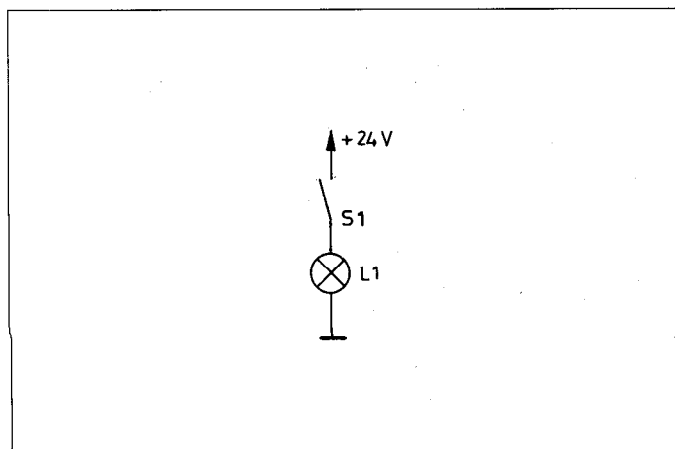

b)

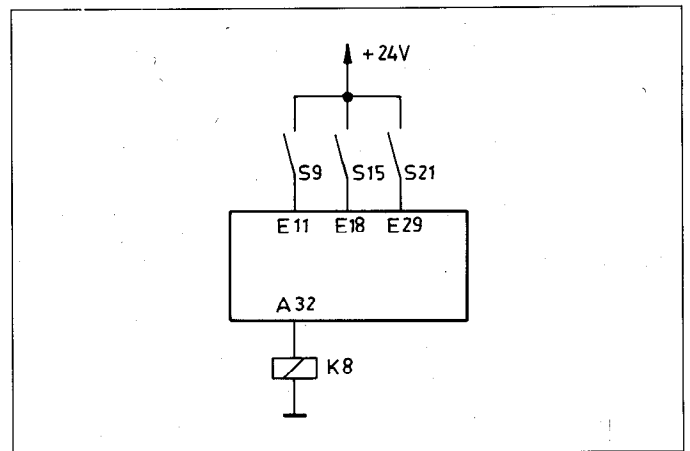

The relay K8 should energise when the contacts S9 or S15 or S21 of any combination therefore are simultaneously closed.

PLC-Program: O E11
 O E18
 O E 29
 = A32

This PLC-program effects a parallel switching of contacts S9, S15 and S21:

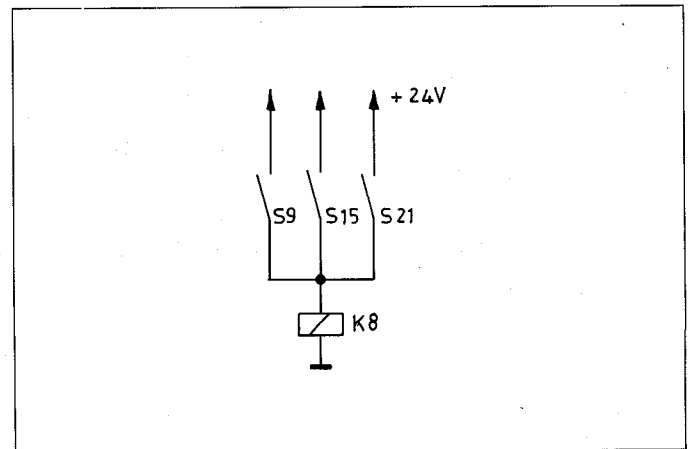

C 1.9.4) Logic sequence with ON-commands

A logic sequence with ON-commands effects a parallel switching of contacts. These contacts are normally closed. This corresponds to an OR-Gate with inverted operand.

PLC-Program	Gating-logic	Abbreviated symbol	Truth table			Contact example
			E1	E2	A1	
ON E1 ON E2 = A1			0	0	1	
			0	1	1	
			1	0	1	
			1	1	0	

It can be deduced from the truth table that this logic element is behaving as a NAND-function. This also follows the rules governing the Boolean Algebra:

$$\overline{E1} + \overline{E2} = \overline{E1 \times E2}$$

Examples:

a)

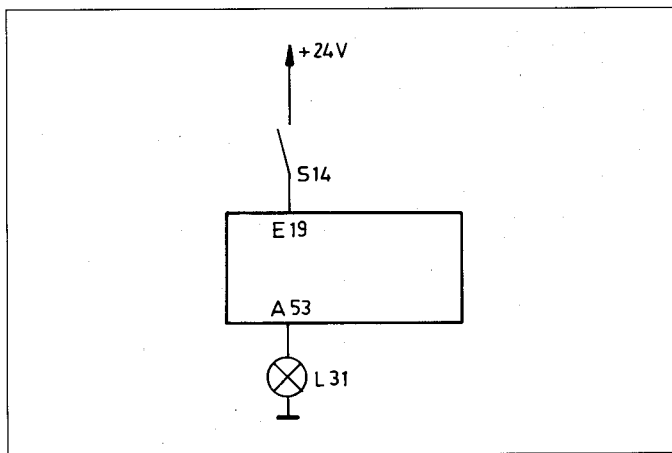

Lamp 31 should illuminate in the event of contact S14 being open.

PLC-Program: ON E19
= A53

This PLC-program effects the following switching:

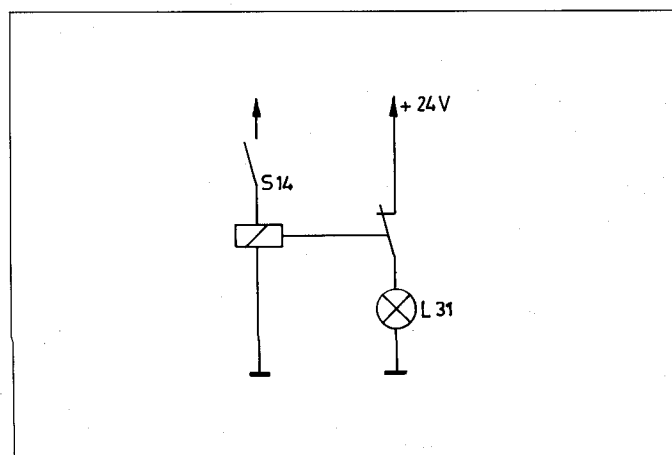

b)

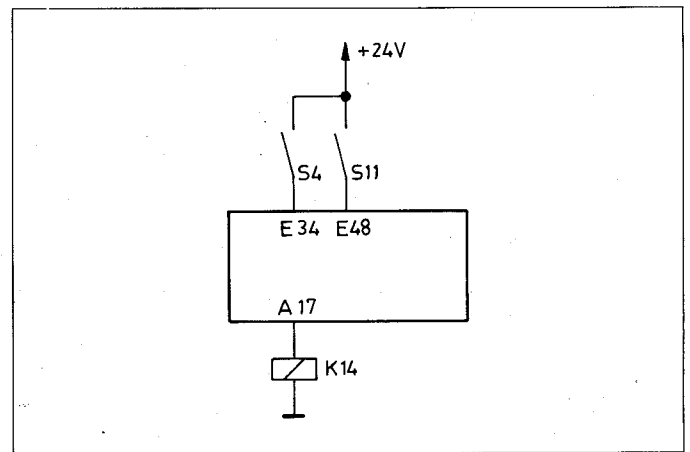

The relay K14 should energise when contact S4 or S11, or both, are open.

PLC-Program: ON E34
ON E48
= A17

This PLC-program effects the following switching:

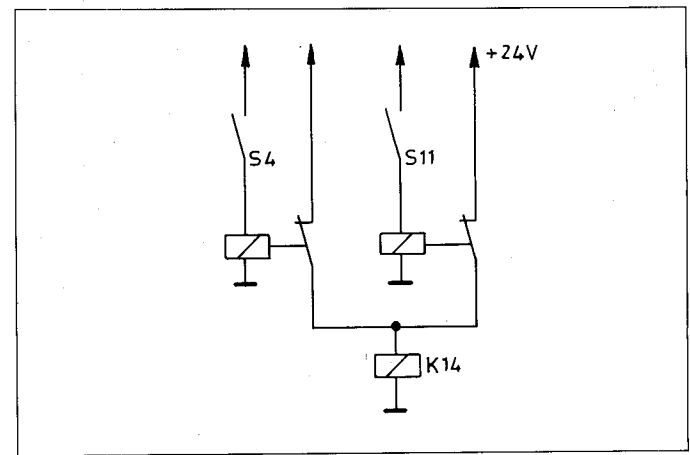

C 1.9.5) Logic sequence with XO/XON commands

A logic sequence with XO or XON-commands can, for example, be used for a parity-check.

Example:

A 3 bit binary number is to be checked for parity with the aid of a logic sequence consisting of XO-commands.

PLC-Program	Gating logic	Truth table																																				
<pre>XO E1 XO E2 XO E3 = A1</pre>		<table border="1"> <thead> <tr> <th>E1</th> <th>E2</th> <th>E3</th> <th>A1</th> </tr> </thead> <tbody> <tr><td>0</td><td>0</td><td>0</td><td>0</td></tr> <tr><td>0</td><td>0</td><td>1</td><td>1</td></tr> <tr><td>0</td><td>1</td><td>0</td><td>1</td></tr> <tr><td>0</td><td>1</td><td>1</td><td>0</td></tr> <tr><td>1</td><td>0</td><td>0</td><td>1</td></tr> <tr><td>1</td><td>0</td><td>1</td><td>0</td></tr> <tr><td>1</td><td>1</td><td>0</td><td>0</td></tr> <tr><td>1</td><td>1</td><td>1</td><td>1</td></tr> </tbody> </table>	E1	E2	E3	A1	0	0	0	0	0	0	1	1	0	1	0	1	0	1	1	0	1	0	0	1	1	0	1	0	1	1	0	0	1	1	1	1
E1	E2	E3	A1																																			
0	0	0	0																																			
0	0	1	1																																			
0	1	0	1																																			
0	1	1	0																																			
1	0	0	1																																			
1	0	1	0																																			
1	1	0	0																																			
1	1	1	1																																			

The logic sequence produces a logic "1" for odd parity and a logic "0" for even parity.

The parity-check can also be carried out using a logic sequence consisting of XON-commands.

PLC-Program	Gating logic	Truth table																																				
<pre>XON E1 XON E2 XON E3 = A1</pre>		<table border="1"> <thead> <tr> <th>E1</th> <th>E2</th> <th>E3</th> <th>A1</th> </tr> </thead> <tbody> <tr><td>0</td><td>0</td><td>0</td><td>1</td></tr> <tr><td>0</td><td>0</td><td>1</td><td>0</td></tr> <tr><td>0</td><td>1</td><td>0</td><td>0</td></tr> <tr><td>0</td><td>1</td><td>1</td><td>1</td></tr> <tr><td>1</td><td>0</td><td>0</td><td>0</td></tr> <tr><td>1</td><td>0</td><td>1</td><td>1</td></tr> <tr><td>1</td><td>1</td><td>0</td><td>1</td></tr> <tr><td>1</td><td>1</td><td>1</td><td>0</td></tr> </tbody> </table>	E1	E2	E3	A1	0	0	0	1	0	0	1	0	0	1	0	0	0	1	1	1	1	0	0	0	1	0	1	1	1	1	0	1	1	1	1	0
E1	E2	E3	A1																																			
0	0	0	1																																			
0	0	1	0																																			
0	1	0	0																																			
0	1	1	1																																			
1	0	0	0																																			
1	0	1	1																																			
1	1	0	1																																			
1	1	1	0																																			

The logic sequence produces a logic "0" for odd parity and a logic "1" for even parity.

C 1.9.6) Programming of an arbitrary logic sequence

Arbitrary logic sequences may be assembled from various logic commands.

Example:

```
U   E27
O   E13
ON  E23
XO  E18
=   A27
```

This programme effects the following switching:

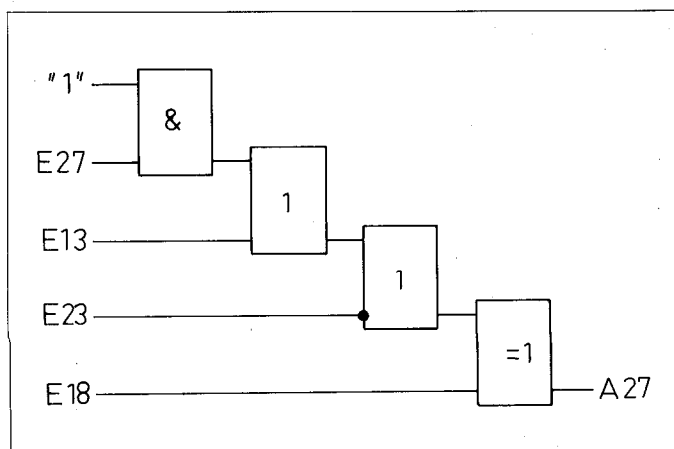

C 1.10) Setting and resetting of a marker

With the aid of the command S or SN, a marker can be set, dependent upon the preceding logic result.

With the aid of the command R or RN, a marker can be reset, dependent upon the preceding logic result.

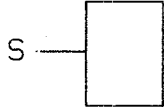
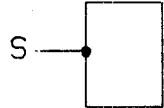
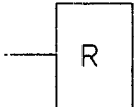
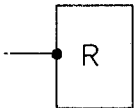
Function	Abbreviation	Symbol	PLC-Programme
Set marker or output if previous gating result is "1"	S		U E1 U M10 S M15
Set marker or output if previous gating result is "0"	SN		U E1 U M11 SN M16
Reset marker or output if previous gating result is "1"	R		U M10 R M16
Reset marker or output if previous gating result is "0"	RN		U M11 RN M15

Examples:

a)

Setting a marker

PLC-Program: U E25
 U M33
 U M61
 S M300

If input 25 and markers 33 and 61 are logic "1", then marker 300 will be set to "1". In contrast to the = - functions, marker 300 remains set even if the logic result in the next PLC-program cycle produces logic "0". Normally, the marker is reset by the command R or RN.

b)

Resetting of a memory location

PLC-Program: U E18
 U E39
 R M300

C 2) Address allocation for PLC-markers

C 2.1) User markers: Address letter M

Address	Description
M 0 – M 999	User markers which are available for use and are reset after powering up
M 1000 – M 1999	User markers which are available for use and remain unchanged in memory after a power interruption. These markers remain unaffected after powering up. These markers can be erased with the code number 531210

C 2.2) Markers for the signal exchanges between PLC and NC: Address letter M

Address	Description
M 2000 – M 2447	Markers for signals from the NC to the PLC (NC → PLC).
M 2448 – M 3023	Markers for signals from the PLC to the NC (PLC → NC).

C 2.2.1) Markers for axes: X, Y, Z, IV

C 2.2.1.1) Release of axes

Marker No.	Function	Signal direction
2000	Axis release X	NC → PLC
2001	Axis release Y	
2002	Axis release Z	
2003	Axis release IV	

The markers for the axis release are set by the NC-part as follows:

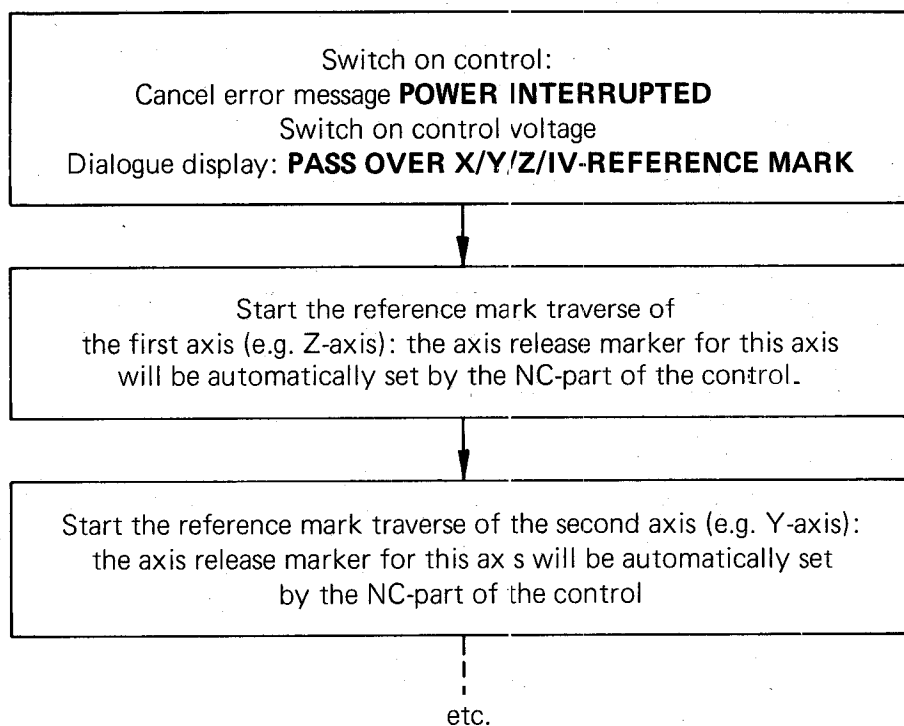

The axis release markers remain set to "1" after traversing over the reference marks, thus keeping the machine axes in closed positioning loop through the control.

Exception:

The axis release markers are reset should a position loop be inhibited by the PLC-part (e.g. in order to clamp an axis, see section C 2.2.1.3).

C 2.2.1.2) Axes in position: X, Y, Z, IV

Marker No.	Function	Signal direction
2008	X-Axis in Position	NC → PLC
2009	Y-Axis in Position	
2010	Z-Axis in Position	
2011	IV-Axis in Position	

When the axes X, Y, Z or IV have achieved the positioning tolerance (defined as a window in parameters 58 and 192) after a move, the corresponding markers are set to "1" by the NC-part of the control (this also applies to the condition after power switch-on).

When the axes X, Y, Z or IV are moving and are not within the positioning-window: the corresponding markers are reset to zero by the NC-part of the control (this also applies during the reference mark approach procedure).

Note:

The marker "axis in position" is not set for contours which can be machined at a constant contouring speed.

Setting only takes place:

.for discontinuous contours (e.g. internal corners)

.with an interruption of the programme run

C 2.2.1.3) Inhibiting the Servo loop

Marker No.	Function	Signal direction
2492 2493 2494 2495	Enable the servo loop for the X-axis Enable the servo loop for the Y-axis Enable the servo loop for the Z-axis Enable the servo loop for the IV-axis	PLC → NC
2544 2545 2546 2547	Open X-axis servo loop Open Y-axis servo loop Open Z-axis servo loop Open IV-axis servo loop	

Operation with open loop control (after a positioning procedure) generally implies a longer delay in switching axes over. Since these delays are unnecessary for machines with permanently activated live servo control loops, the marker **“Enable Servo loop” (markers 2492 to 2495)** has been made available. Only when these markers are set, does the NC-part of the control wait for the **PLC-signal “Open Servo loop” (markers 2544 to 2547)**, when the marker **“Axis in Position” (markers 2008 to 2011)** from the NC-part of the control has been set.

In operation without “Enable Opening of Control Loop”, the switching over from one axis to another takes place as quickly as possible.

Should a control loop be opened (e.g. for clamping of axes), the markers are set as follows:

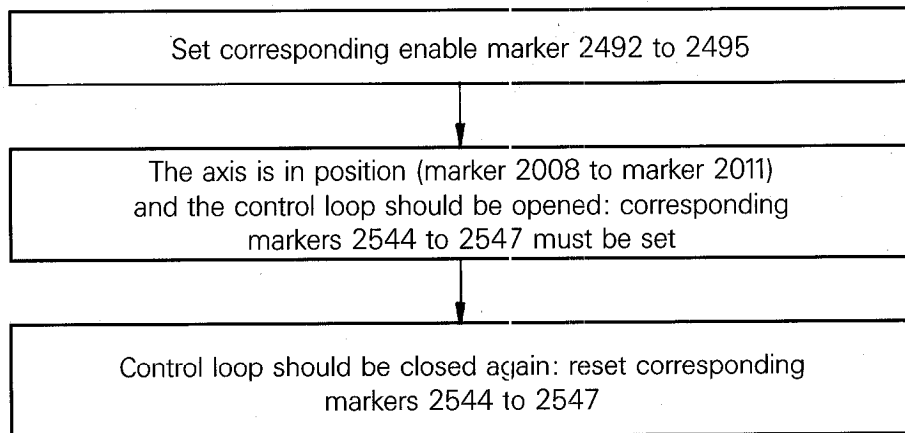

C 2.2.1.4) Markers for transfer of actual position values as nominal values (Teach-in)

Marker No.	Function	Signal direction
2552	Teach-in for position loop X-axis	PLC → NC
2553	Teach-in for position loop Y-axis	
2554	Teach-in for position loop Z-axis	
2555	Teach-in for position loop IV-axis	

If the appropriate markers 2552 to 2555 are set to logic "1", the momentary position value is transformed into a nominal value.

Note:

Teach-in, is only possible in the manual operating mode.

C 2.2.1.5) Current tool-axis

Marker No.	Function	Signal direction
2100	X-axis is tool axis	NC → PLC
2101	Y-axis is tool axis	
2102	Z-axis is tool axis	
2103	V th axis is tool axis	

C 2.2.1.6) Traverse-dependent lubrication impulses: X, Y, Z, IV

Marker No.	Function	Signal direction
2012	Lubrication impulse necessary X , when traverse limit exceeded	NC → PLC
2013	Lubrication impulse necessary Y , when traverse limit exceeded	
2014	Lubrication impulse necessary Z , when traverse limit exceeded	
2015	Lubrication impulse necessary IV , when traverse limit exceeded	

The traverse section, after which a lubrication-impulse-marker should be set, is specified for each axis as a machine parameter (Machine parameters 159 to 162).

Entry is in 65536 µm-units, i.e. to obtain the entry value, the required traversing distance in µm (microns) is to be divided by 65536 µm (microns).

Example:

Required traversing distance: 100000000 µm
 Entry value: $\frac{100000000 \text{ µm}}{65536 \text{ µm}} \approx 1526$

When the traverse limit for an axis is exceeded, the corresponding lubrication-impulse-marker is then set to "1" by the NC-part of the control.

The summation of the traverse sections covered can be reset to zero by the PLC-programme using the following markers.

Marker No.	Function	Signal direction
2548	The summation of the traverse – dependent lubrication to be reset in the X-axis	PLC → NC
2549	The summation of the traverse – dependent lubrication to be reset in the Y-axis	
2550	The summation of the traverse – dependent lubrication to be reset in the Z-axis	
2551	The summation of the traverse – dependent lubrication to be reset in the IV-axis	

C 2.2.1.7) PLC-Positioning

Marker No.	Function	Error message	Signal direction
2452	Start PLC-positioning X axis	E	PLC → NC
2453	Start PLC-positioning Y axis	F	
2454	Start PLC-positioning Z axis	G	
2455	Start PLC-positioning IV axis	H	
2468	Complemented* start PLC-positioning X axis		
2469	Complemented* start PLC-positioning Y axis		
2470	Complemented* start PLC-positioning Z-axis		
2471	Complemented* start PLC-positioning IV axis		
2560	PLC-positioning X axis (lsb)		
2561	PLC-positioning X axis		
2562	PLC-positioning X axis		
2563	PLC-positioning X axis		
2564	PLC-positioning X axis (msb)		
2565	PLC-positioning Y axis (lsb)		
2566	PLC-positioning Y axis		
2567	PLC-positioning Y axis		
2568	PLC-positioning Y axis		
2569	PLC-positioning Y axis (msb)		
2570	PLC-positioning Z axis (lsb)		
2571	PLC-positioning Z axis		
2572	PLC-positioning Z axis		
2573	PLC-positioning Z axis		
2574	PLC-positioning Z axis (msb)		
2575	PLC-positioning IV axis (lsb)		
2576	PLC-positioning IV axis		
2577	PLC-positioning IV axis		
2578	PLC-positioning IV axis		
2579	PLC-positioning IV axis (msb)		

Thirty-one position values can be programmed via machine parameters 126 to 156. These positions can be called up via the PLC-program, e.g. for the approach to a tool-change position. The markers for the PLC-positioning are only acted upon during the output of a G-M-S-T-strobe signal.

Note:

- .Software limit switches are not taken into account.
- .Tool compensations are not considered.
- .A PLC-positioning procedure automatically ends path compensation.

*For programming of the complement marker please refer to section C 2.2.6

The PLC-positions are coded as follows:

PLC-Code	calls-up the Position in Machine Parameter
0 0 0 0 0	126
0 0 0 0 1	127
0 0 0 1 0	128
0 0 0 1 1	129
0 0 1 0 0	130
0 0 1 0 1	131
0 0 1 1 0	132
0 0 1 1 1	133
0 1 0 0 0	134
0 1 0 0 1	135
0 1 0 1 0	136
0 1 0 1 1	137
0 1 1 0 0	138
0 1 1 0 1	139
0 1 1 1 0	140
0 1 1 1 1	141
1 0 0 0 0	142
1 0 0 0 1	143
1 0 0 1 0	144
1 0 0 1 1	145
1 0 1 0 0	146
1 0 1 0 1	147
1 0 1 1 0	148
1 0 1 1 1	149
1 1 0 0 0	150
1 1 0 0 1	151
1 1 0 1 0	152
1 1 0 1 1	153
1 1 1 0 0	154
1 1 1 0 1	155
1 1 1 1 0	156

Note:

PLC-code 11111 addresses the reference mark as PLC-position. This is not possible with distance-coded reference marks.

A PLC-positioning (e. g. for the X-axis) is programmed as follows:

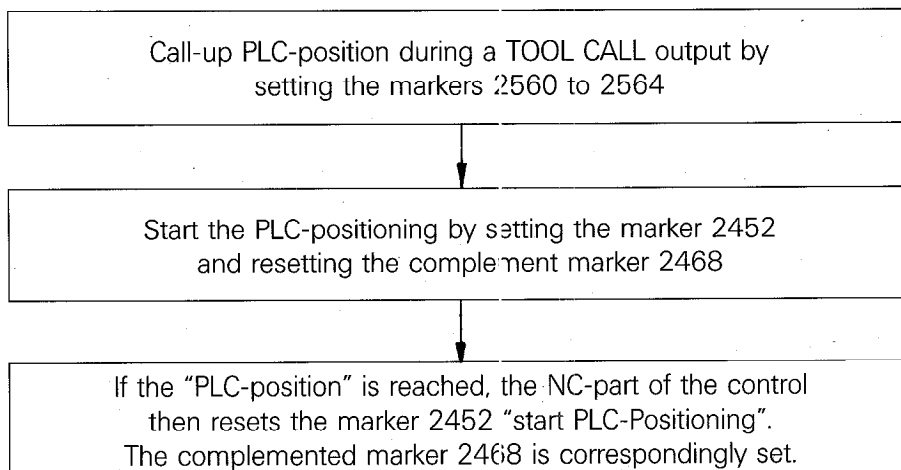

Termination of PLC-positioning:

When terminating a PLC-positioning the markers for "start PLC-positioning" (M 2452, M 2453, M 2454, M 2455) and "complemented start PLC-positioning" (M 2463, M 2469, M 2470, M 2471) are reset.

Note:

The feedrate for the PLC-positioning is specified in machine parameters 163 to 166. In the event of simultaneous PLC-positioning (up to 3 axes), the PLC-positions will be approached in a straight line at the lowest of the specified feedrates.

C 2.2.2) Markers for M-S-T-Code-Outputs

C 2.2.2.1) Coded M-S-T-Code Outputs

Marker No.	Function	Signal direction
2032	1. Bit T-Code (lsb)	NC → PLC
2033	2. Bit T-Code	
2034	3. Bit T-Code	
2035	4. Bit T-Code	
2036	5. Bit T-Code	
2037	6. Bit T-Code	
2038	7. Bit T-Code	
2039	8. Bit T-Code (msb)	
2044	Strobe signal for S-Code	
2045	Strobe signal for M-Code	
2046	Strobe signal for T-Code	
2047	Strobe signal for second T-Code (see machine parameter 157)	
2064	1. Bit S-Code (lsb)	
2065	2. Bit S-Code	
2066	3. Bit S-Code	
2067	4. Bit S-Code	
2068	5. Bit S-Code	
2069	6. Bit S-Code	
2070	7. Bit S-Code	
2071	8. Bit S-Code (msb)	
2072	1. Bit M-Code (lsb)	
2073	2. Bit M-Code	
2074	3. Bit M-Code	
2075	4. Bit M-Code	
2076	5. Bit M-Code	
2077	6. Bit M-Code	
2078	7. Bit M-Code	
2079	8. Bit M-Code (msb)	
2481	Feedback S-Code complete	PLC → NC
2482	Feedback M-Code complete	
2483	Feedback T-Code complete	
2484	Feedback 2nd T-Code complete	

The markers for the M-S-T outputs and the markers for the strobe signals are set by the NC part of the control when an auxiliary function (M), coded spindle R.P.M. (S), or tool number (T) is programmed.

Note:

The output of the S and T-functions can be suppressed by machine parameters 61 and 62.

The programmed and unsuppressed S and T-functions are, in the event of a tool call, output in the following sequence by the NC part of the control:

- .first the tool number T
- .finally the spindle RPM S

In the event that an automatic tool-changer with tool magazine is installed, it can be necessary, that after the changing of the current tool, a second tool number is output in addition for the next tool. The second T-code can be activated by machine parameter 157 and will be output after the feedback "first T-code completed" (i.e. first tool changed). A search can then be made in the tool magazine for the following tool prior to the next tool change.

The setting and resetting of the corresponding markers proceeds as follows:

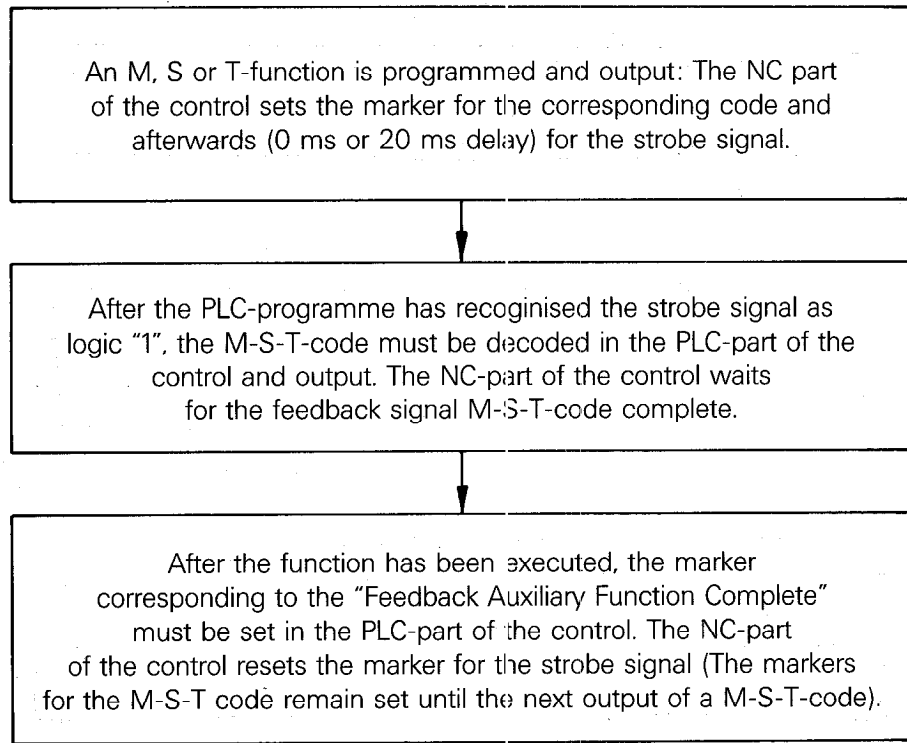

Note:

The timing for the code output must be implemented via the PLC.

For an example of the M-S-T-code output, please refer to section D 3.

C 2.2.2.2) Decoded M-Code output

Marker No.	Function	Signal direction
1900	Auxiliary function M00	NC → PLC
1901	Auxiliary function M01	
1902	Auxiliary function M02	
1903	Auxiliary function M03	
1904	Auxiliary function M04	
1905	Auxiliary function M05	
1906	Auxiliary function M06	
1907	Auxiliary function M07	
1908	Auxiliary function M08	
1909	Auxiliary function M09	
1910	Auxiliary function M10	
1911	Auxiliary function M11	
1912	Auxiliary function M12	
1913	Auxiliary function M13	
1914	Auxiliary function M14	
1915	Auxiliary function M15	
1916	Auxiliary function M16	
1917	Auxiliary function M17	
1918	Auxiliary function M18	
1919	Auxiliary function M19	
1920	Auxiliary function M20	
1921	Auxiliary function M21	
1922	Auxiliary function M22	
1923	Auxiliary function M23	
1924	Auxiliary function M24	
1925	Auxiliary function M25	
1926	Auxiliary function M26	
1927	Auxiliary function M27	
1928	Auxiliary function M28	
1929	Auxiliary function M29	
1930	Auxiliary function M30	
1931	Auxiliary function M31	
1932	Auxiliary function M32	
1933	Auxiliary function M33	
1934	Auxiliary function M34	
1935	Auxiliary function M35	
1936	Auxiliary function M36	
1937	Auxiliary function M37	
1938	Auxiliary function M38	
1939	Auxiliary function M39	
1940	Auxiliary function M40	
1941	Auxiliary function M41	
1942	Auxiliary function M42	
1943	Auxiliary function M43	
1944	Auxiliary function M44	
1945	Auxiliary function M45	
1946	Auxiliary function M46	
1947	Auxiliary function M47	
1948	Auxiliary function M48	
1949	Auxiliary function M49	
1950	Auxiliary function M50	
1951	Auxiliary function M51	
1952	Auxiliary function M52	

Marker No.	Function	Signal direction
1953	Auxiliary function M53	NC → PLC
1954	Auxiliary function M54	
1955	Auxiliary function M55	
1956	Auxiliary function M56	
1957	Auxiliary function M57	
1958	Auxiliary function M58	
1959	Auxiliary function M59	
1960	Auxiliary function M60	
1961	Auxiliary function M61	
1962	Auxiliary function M62	
1963	Auxiliary function M63	
1964	Auxiliary function M64	
1965	Auxiliary function M65	
1966	Auxiliary function M66	
1967	Auxiliary function M67	
1968	Auxiliary function M68	
1969	Auxiliary function M69	
1970	Auxiliary function M70	
1971	Auxiliary function M71	
1972	Auxiliary function M72	
1973	Auxiliary function M73	
1974	Auxiliary function M74	
1975	Auxiliary function M75	
1976	Auxiliary function M76	
1977	Auxiliary function M77	
1978	Auxiliary function M78	
1979	Auxiliary function M79	
1980	Auxiliary function M80	
1981	Auxiliary function M81	
1982	Auxiliary function M82	
1983	Auxiliary function M83	
1984	Auxiliary function M84	
1985	Auxiliary function M85	
1986	Auxiliary function M86	
1987	Auxiliary function M87	
1988	Auxiliary function M88	
1989	Auxiliary function M89	
2496	Release marker for decoded M-Code output	

If the marker 2496 is set, the programmed M-functions are output in decoded form via markers 1900 to 1989. The release marker 2496 is necessary since the markers 1900 to 1989 are located within the range of user markers. If markers 1900 – 1989 are required for other functions, marker 2496 must be reset.

Please note:

There is no output with markers M90 to M99.

C 2.2.2.3) Transfer of machine parameter for rpm-limitation into the PLC-programme

Marker No.	Function	Signal direction
2080	1. Bit for min. rpm (lsb)	PLC → NC
2081	2. Bit for min. rpm	
2082	3. Bit for min. rpm	
2083	4. Bit for min. rpm	
2084	5. Bit for min. rpm	
2085	6. Bit for min. rpm	
2086	7. Bit for min. rpm	
2087	8. Bit for min. rpm (msb)	
2088	1. Bit for step width (lsb)	
2089	2. Bit for step width	
2090	3. Bit for step width	
2091	4. Bit for step width (msb)	

The minimum rpm and the step width from the machine parameter "limitation of rpm-code" (machine parameter 63) is transferred into the markers 2080 to 2091.

C 2.2.3) Markers for analogue output of the spindle speed

Marker No.	Function	Signal direction	
2004	"0" means: The analogue voltage for the spindle drive is located in the ramp. With a change of the S-override potentiometer of > 2%, the marker 2004 is also reset	NC → PLC	
2005	"1" means: The analogue voltage for the spindle drive is 0 V		
2042	"1" means: The control operates with S-analogue "0" means: The control operates with coded output of spindle rpm.		
2043	Strobe signal gear range code (G-Code) for S-Analogue output		
2104	1. Bit gear range code for S Analogue (lsb)		
2105	2. Bit gear range code for S Analogue		
2106	3. Bit gear range code for S Analogue (msb)		
2480	Feedback signal gear range code for S analogue complete		PLC → NC
2485	Status display and output of analogue voltage for M 03		
2486	Status display and output of analogue voltage for M 04		
2487	Status display M 05		
2489	Inversion of analogue voltage. The polarity which has been determined by MP 172 is reversed.		
2490	Spindle CW for gearchange		
2491	Spindle CW for gearchange		

The spindle speed gear ranges are specified via machine parameters (MP78 – 85) when an analogue output for the spindle speed is selected (S-analogue is activated via machine parameter 62).

Please note:

With controls TNC 155, software versions 01 and 02 and TNC 150, the PLC-markers 2490 and 2491 are only referred to by the NC part of the control during output of a G-strobe signal.

With controls TNC 155, as of software versions 03, and with TNC 151, the PLC markers 2490 and 2491 are constantly active with stationary spindle (M 05).

When a spindle speed requiring a new gear range, is programmed, the markers will be set as follows:

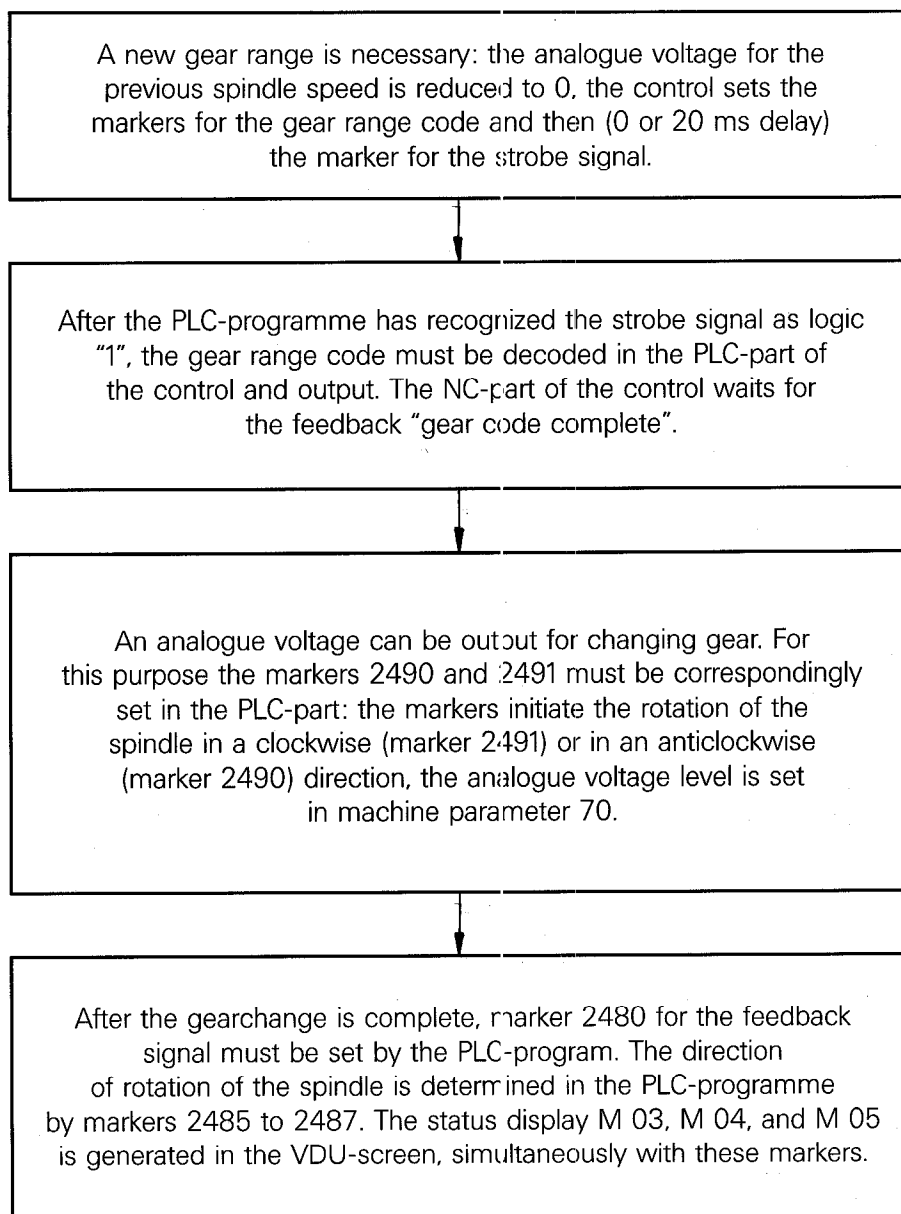

After the gearchange is complete, the control outputs the relevant analogue voltage (determined by machine parameters 86, 87, 88, 89).

For an example of the programming of the analogue spindle speed, please refer to section D 3.

C 2.2.4) Markers for the Vth axis for spindle orientation (option)

The fifth axis is preferably used for the orientation of the main working spindle. Spindle positioning is effected via the PLC-program with a PLC-positioning routine.

Marker No.	Function	Signal direction
2499	Inhibit positioning loop for fifth axis. A pre-marker is not required for inhibiting the positioning loop.	PLC → NC
2527	Start PLC-positioning of fifth axis	
2543	Complementary start of PLC-positioning for fifth axis	
2580	PLC-positioning of fifth axis (lsb)	
2581	PLC-positioning of fifth axis	
2582	PLC-positioning of fifth axis	
2583	PLC-positioning of fifth axis	
2584	PLC-positioning of fifth axis (msb)	

Markers 2580 to 2584 call-up the following PLC-positions:

PLC-code	calls position in machine parameter
0 0 0 0 0	126
0 0 0 0 1	127
0 0 0 1 0	128
0 0 0 1 1	129
0 0 1 0 0	130
0 0 1 0 1	131
0 0 1 1 0	132
0 0 1 1 1	133
0 1 0 0 0	134
0 1 0 0 1	135
0 1 0 1 0	136
0 1 0 1 1	137
0 1 1 0 0	138
0 1 1 0 1	139
0 1 1 1 0	140
0 1 1 1 1	141
1 0 0 0 0	142
1 0 0 0 1	143
1 0 0 1 0	144
1 0 0 1 1	145
1 0 1 0 0	146
1 0 1 0 1	147
1 0 1 1 0	148
1 0 1 1 1	149
1 1 0 0 0	150
1 1 0 0 1	151
1 1 0 1 0	152
1 1 0 1 1	153
1 1 1 0 0	154
1 1 1 0 1	155
1 1 1 1 0	156

If markers 2580 to 2584 are all set to logical 1, then the position of the fifth axis as per cycle definition "orientation" is transferred.

If the cycle "orientation" was not processed in the program run, then the spindle positions on the reference mark.

Spindle orientation is effected with the rotation direction (M03 or M04) last programmed. If the spindle is at standstill, then orientation is in the clockwise direction (M03).

C 2.2.5) Markers for TNC-buttons

C 2.2.5.1) Operating mode-code

Marker No.	Function	Signal direction
2176	1. Bit for the operating mode-code (lsb)	NC → PLC
2177	2. Bit for the operating mode-code	
2178	3. Bit for the operating mode-code	
2179	4. Bit for the operating mode-code (msb)	

The operating mode code is determined by the selected operating mode. The operating modes are coded as follows:

0000 =	Programme entry and editing
0001 =	Manual operation
0010 =	Electronic handwheel
0011 =	Single block positioning with MDI
0100 =	Program run, single block
0101 =	Automatic programme run
0110 =	Programme test

C 2.2.5.2) Markers for the decoded operating mode-code

Marker No.	Function	Signal direction
2049	Programming during programme run	NC → PLC
2050	Programme entry and editing	
2051	Manual operation	
2052	Electronic handwheel	
2053	Single block positioning with MDI	
2054	Programme run, single block	
2055	Automatic programme run	
2056	Programme test	
2057	Approach to reference point	

With TNC 150, as of software version 05.

Markers 2049 to 2057 depend on the operating mode which has been selected.

C 2.2.5.3) Currently activated axis button: X, Y, Z, IV

Marker No.	Function	Signal direction
2096	Currently activated TNC-axis button X	NC → PLC
2097	Currently activated TNC-axis button Y	
2098	Currently activated TNC-axis button Z	
2099	Currently activated TNC-axis button IV	

These markers identify the currently activated TNC-axis button: The corresponding symbol will be displayed on the VDU-screen in reverse image (e.g. **X**).

These markers can, for example, be employed for an external handwheel display. An external handwheel control panel can be implemented by using these markers in conjunction with the markers for external operation of the TNC-buttons. (see section C 2.2.5.4).

C 2.2.5.4) Code for the external selection of TNC-buttons

Marker No.	Function	Signal direction
2800	1. Bit TNC-button code (lsb)	PLC → NC
2801	2. Bit TNC-button-code	
2802	3. Bit TNC-button-code	
2803	4. Bit TNC-button-code	
2804	5. Bit TNC-button-code	
2805	6. Bit TNC-button-code	
2806	7. Bit TNC-button-code	
2807	8. Bit TNC-button-code (msb)	
2808	Strobe for button-code	

Each button operation on the front panel of the TNC can be simulated by an external signal via the markers for the TNC-button-code.

However, the following should be noted:

.The TNC-button code must be reset by a pulse

.for the strobe of a button code, only one PLC-cycle may be set, otherwise the same button will be simulated several times

































.After execution of the function the control resets the button code After reset of the TNC-button code, a new press of the button can be simulated.

































The buttons are coded as follows:

Button	Code	
	msb	lsb
	0011	1011
	0011	1100
	0011	1101
	0011	1110
	0011	1111
	0100	0000
	0100	0001
MOD	0100	0010
P	0100	0011
I	0100	0100
PGM CALL	0100	0101
Button to right of		
	0100	0110
	0100	0111
	0100	1000
	0100	1001
	0100	1010
	0100	1011
	0100	1100
	0100	1101
TOUCH PROBE	0100	1110
TOOL DEF	0101	0100
TOOL CALL	0101	0101
R ^L	0101	0110
R ^R	0101	0111
	0101	1000
	0101	1001
	0101	1010
CYCL DEF	0101	1011
CYCL CALL	0101	1100
LBL SET	0101	1101
LBL CALL	0101	1110
NO ENT	0101	1111

Button	Code	
	msb	lsb
	0110	0000
	0110	0001
CL PGM	0110	0010
DEL C	0110	0011
	0110	0100
ENT	0110	0101
GO TO C	0110	0110
	0110	0111
Q DE=	0110	1000
CE	0110	1001
IV	0110	1010
Z	0110	1011
Y	0110	1100
X	0110	1101
Q	0110	1110
0	0110	1111
1	0111	0000
4	0111	0001
7	0111	0010
.	0111	0011
2	0111	0100
5	0111	0101
8	0111	0110
END C	0111	0111
GRAPHICS		
MCD	0111	1000 (for TNC 155)
BLK FORM	0111	1001 (for TNC 155)
MAGN	0111	1010 (for TNC 155)
START	0111	1011 (for TNC 155)
	0111	1100
3	0111	1101
6	0111	1110
9	0111	1111

C 2.2.5.5) Markers for inhibiting buttons

Marker No.	Function	Signal direction
2182	Inhibited TNC-button pressed	NC → PLC
2855	 Inhibit button	PLC → NC
2856	 Inhibit button	
2857	 Inhibit button	
2858	 Inhibit button	
2859	 Inhibit button	
2860	 Inhibit button	
2861	 Inhibit button	
2862	 Inhibit button	
2863	 Inhibit button	
2864	 Inhibit button	
2865	 Inhibit button	
2866	Button to right of  inhibit	
2867	 Inhibit button	
2868	 Inhibit button	
2869	 Inhibit button	
2870	 Inhibit button	
2871	 Inhibit button	
2872	 Inhibit button	
2873	 Inhibit button	
2874	 Inhibit button	
2880	 Inhibit button	
2881	 Inhibit button	
2882	 Inhibit button	
2883	 Inhibit button	
2884	 Inhibit button	
2885	 Inhibit button	
2886	 Inhibit button	
2887	 Inhibit button	
2888	 Inhibit button	
2889	 Inhibit button	
2890	 Inhibit button	
2891	 Inhibit button	

Marker No.	Function	Signal direction
2892	 Inhibit button	PLC → NC
2893	 Inhibit button	
2894	 Inhibit button	
2895	 Inhibit button	
2896	 Inhibit button	
2897	 Inhibit button	
2898	 Inhibit button	
2899	 Inhibit button	
2900	 Inhibit button	
2901	 Inhibit button	
2902	 Inhibit button	
2903	 Inhibit button	
2904	 Inhibit button	
2905	 Inhibit button	
2906	 Inhibit button	
2907	 Inhibit button	
2908	 Inhibit button	
2909	 Inhibit button	
2910	 Inhibit button	
2911	 Inhibit button	
2912	 Inhibit button	
2913	 Inhibit button	
2914	 Inhibit button	
2915	 Inhibit button	
2916	 Inhibit button (for TNC 155)	
2917	 Inhibit button (for TNC 155)	GRAPHICS
2918	 Inhibit button (for TNC 155)	
2919	 Inhibit button (for TNC 155)	
2920	 Inhibit button	
2921	 Inhibit button	
2922	 Inhibit button	
2923	 Inhibit button	

The buttons on the TNC front panel can be inhibited by setting the corresponding markers. When an inhibited TNC-button is pressed, the NC-part signals this by setting the marker 2182

This marker must be reset again by the PLC-programme.

C 2.2.6) Markers for external buttons and switches

Marker No.	Function	Error message	Signal direction
2448	NC-Start	A	PLC → NC
2449	NC-Rapid	B	
2450	Latching function for Manual traverse	C	
2451	Feed release	D	
2456	Manual traverse X+	I	
2457	Manual traverse X-	J	
2458	Manual traverse Y+	K	
2459	Manual traverse Y-	L	
2460	Manual traverse Z+	M	
2461	Manual traverse Z-	N	
2462	Manual traverse IV+	C	
2463	Manual traverse IV-	P	
2464	Complemented NC-Start		
2465	Complemented NC-Rapid Override		
2466	Complement latching Function for manual traverse		
2467	Complemented feed release		
2472	Complemented manual traverse X+		
2473	Complemented manual traverse X-		
2474	Complemented manual traverse Y+		
2475	Complemented manual traverse Y-		
2476	Complemented manual traverse Z+		
2477	Complemented manual traverse Z-		
2478	Complemented manual traverse IV+		
2479	Complemented manual traverse IV-		
2488	NC-Stop ("0" corresponds to Stop)		
2556	Reference end position for the X-axis		
2557	Reference end position for the Y-axis		
2558	Reference end position for the Z-axis		
2559	Reference end position for the IV-axis		

Important functions are controlled via marker and complementary markers.

The signals from external buttons and switches must set the corresponding markers in the PLC-program and generate the complemented markers with the inverted information in the same PLC-cycle. Should both markers not be correctly set or reset, then the flashing message

ERROR IN PC-PROGRAM A/B/C ...

is displayed.

The displayed letter A, B, C etc, indicates at which marker the fault lies (see list above).

Example:

The NC-start button is provided with two normally open contacts. The markers are then set as follows:

U E18 (first contact of the NC-start-button)
= M2448

UN E19 (second contact of the NC-start-button)
= M2464

If only one NC-Start contact exists, the program may be written in the following way:

U E18 (NC-Start button)
= M2448

UN E18 (NC-Start button)
= M2464

The following program is wrong and should not be implemented

U E18 (NC-start button)
= M2448

UN M2448
= M2464

A defect in the memory cell M 2448 cannot be recognized with this method of programming!

C 2.2.7) Markers for ascending and descending edges of PLC-inputs

For ascending edges of PLC-inputs,
markers M1500 to M1627 (E0 to E127)

and for descending edges of PLC-inputs,
markers M1700 to M1827 (E0 to E127)

are set for a PLC-cycle, if marker M2497 has been activated for this function.

C 2.2.8) Markers for control status and error messages/User parameters

Marker No.	Function	Signal direction
2183	Program interruption (Display: "Control in operation" flashing)	NC → PLC
2184	Control in operation (Display: "Control in operation" either on or flashing)	
2190	Eraseable error message is displayed	
2191	Error message: "External emergency stop" is displayed	
2815	Flashing error message from PLC	PLC → NC
2924	Error message 0 from PLC to be displayed in VD J-screen	
2925	Error message 1	
2926	Error message 2	
2927	Error message 3	
2928	Error message 4	
2929	Error message 5	
2930	Error message 6	
2931	Error message 7	
2932	Error message 8	
2933	Error message 9	
2934	Error message 10	
2935	Error message 11	
2936	Error message 12	
2937	Error message 13	
2938	Error message 14	
2939	Error message 15	
2940	Error message 16	
2941	Error message 17	
2942	Error message 18	
2943	Error message 19	
2944	Error message 20	
2945	Error message 21	
2946	Error message 22	
2947	Error message 23	
2948	Error message 24	
2949	Error message 25	
2950	Error message 26	
2951	Error message 27	
2952	Error message 28	
2953	Error message 29	
2954	Error message 30	
2955	Error message 31	
2956	Error message 32	
2957	Error message 33	
2958	Error message 34	
2959	Error message 35	
2960	Error message 36	
2961	Error message 37	
2962	Error message 38	
2963	Error message 39	
2964	Error message 40	
2965	Error message 41	
2966	Error message 42	
2967	Error message 43	
2968	Error message 44	
2969	Error message 45	
2970	Error message 46	
2971	Error message 47	

Marker No.	Function	Signal direction
2972	Error message 48	PLC → NC
2973	Error message 49	
2974	Error message 50	
2975	Error message 51	
2976	Error message 52	
2977	Error message 53	
2978	Error message 54	
2979	Error message 55	
2980	Error message 56	
2981	Error message 57	
2982	Error message 58	
2983	Error message 59	
2984	Error message 60	
2985	Error message 61	
2986	Error message 62	
2987	Error message 63	
2988	Error message 64	
2989	Error message 65	
2990	Error message 66	
2991	Error message 67	
2992	Error message 68	
2993	Error message 69	
2994	Error message 70	
2995	Error message 71	
2996	Error message 72	
2997	Error message 73	
2998	Error message 74	
2999	Error message 75	
3000	Error message 76	
3001	Error message 77	
3002	Error message 78	
3003	Error message 79	
3004	Error message 80	
3005	Error message 81	
3006	Error message 82	
3007	Error message 83	
3008	User parameter 16	
3009	User parameter 15	
3010	User parameter 14	
3011	User parameter 13	
3012	User parameter 12	
3013	User parameter 11	
3014	User parameter 10	
3015	User parameter 9	
3016	User parameter 8	
3017	User parameter 7	
3018	User parameter 6	
3019	User parameter 5	
3020	User parameter 4	
3021	User parameter 3	
3022	User parameter 2	
3023	User parameter 1	

Display: Control in operation

The initial program status is displayed in the VDU-screen of the TNC via the symbol * (see illustration).

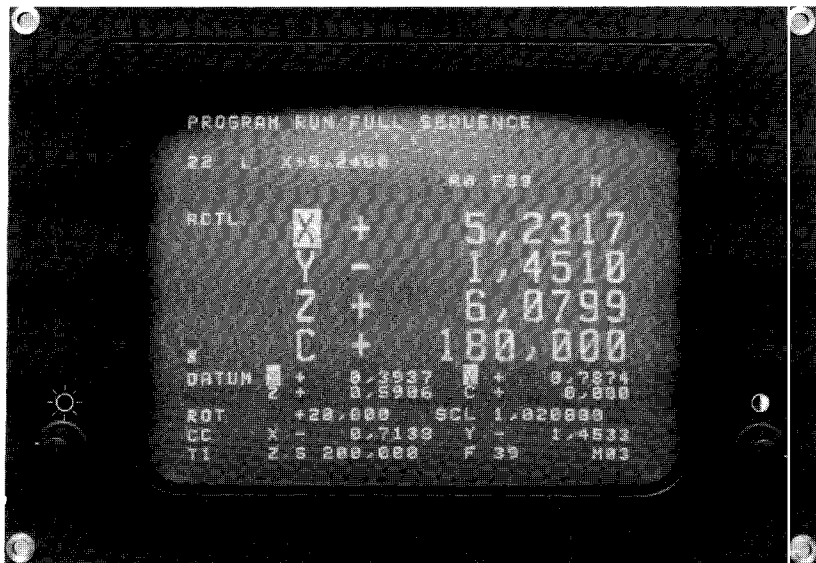

The NC-part of the control signals a program interruption to the PLC via marker 2183 (display flashes). The initial status is signalled via the marker 2184 (display on or flashing). When both markers are reset, the program run has been terminated.

Error message NC → PLC

When an erasable **error message** is displayed in the VDU, the NC-part of the control sets the marker **2190**. When the **error message EXTERNAL EMERGENCY STOP** is displayed, the NC-part of the control sets the marker **2190 and 2191**. With flashing error messages from the NC, the program run of the PLC is halted and the PLC-outputs set to "0".

Error messages PLC → NC

The NC-part of the control can display error messages from the PLC-part. The PLC-error messages are selected via markers **2924 to 3023**.

The error messages are coded from 0 – 99. When a marker for a PLC error message is set, the following error message is displayed, e.g.

PLC: ERROR 58

on the VDU-screen of the control.

Plain language error messages can also be displayed instead of the coded error messages (e.g. Oil pressure too low). The error messages 0 – 34 may have max. 32 characters; the error messages 35 – 83 max. 16 characters and the user parameters 1 – 16.

Should you require specific plain language error messages, please contact your nearest HEIDENHAIN agency.

The setting of the marker 2815 results in the markers 2924 to 3023 being checked. If one of these markers is set, then the error message will be shown as a flashing display. Should none of the markers for the PLC-error messages be set, then

EMERGENCY STOP PLC

is shown as a flashing display.

User parameters

Up to 16 machine parameters can be made accessible to the machine operator via the MOD-function. These user parameters can be assigned by the machine tool builder at his own discretion (refer to Interface manual TNC 151/TNC 155).

The following dialogue texts are contained in the PLC-EPROM for the dialogue display of user parameters.

Dialog-display	Machine parameter
USER PAR. 1	Machine parameter with lowest parameter number
⋮	
USER PAR. 8	Machine parameters allocated according to increasing parameter numbers
⋮	
USER PAR. 16	Machine parameter with the highest parameter number.

Any dialogue text with a max. of 16 characters may be displayed instead of USER PAR. 1 etc. This requires an amendment of the standard PLC-EPROM which can only be performed at the HEIDENHAIN factory in Traunreut, West Germany. Please contact your local HEIDENHAIN-agency or our factory in Traunreut, West Germany.

Please note:

The dialogue texts USER PAR. 1 to USER PAR. 16 are stored in the EPROM under the address of the PLC: ERROR 84 to PLC: ERROR 99. If, however, error messages are required instead of dialogues, the corresponding dialogue texts within the PLC-EPROM must be revised (Address of USER PAR. 1 = Address of PLC: ERROR 84 etc.).

Out of the ASCII signs, the signs from HEX 20 to HEX 5 F are permissible for error messages and dialogs.

C 2.2.9) Transfer of numerical values from the PLC to the NC

Marker No.	Function	Signal direction
2560 2576	Marker for the numerical value which is to be transferred from the PLC to the NC.	PLC → NC
2809	Strobe for transfer of the numerical value	
2810 2811 2812	Data format of numerical value in markers 2560 to 2576	
2816 2817 2818	Assignment of numerical value to Q-parameters Q 100 to Q 107	

Please note:

Markers 2560 to 2576 have now been assigned double functions!
These markers are already being used for PLC-positioning.

Markers 2810, 2811 and 2812 determine the data format of the numerical value which is to be transferred.
At present, the following data format can be defined:

- M 2810 = 0
- M 2811 = 0
- M 2812 = 0

By resetting the markers 2810, 2811 and 2812 it can be determined that the information of markers 2560 to 2576 corresponds to a numerical value with 4 decades, BCD-code with sign.

Marker No.	Function	Signal direction
M 2560 M 2561 M 2562 M 2563	1 st decade (lsb) 1 st decade 1 st decade 1 st decade (msb)	PLC → NC
M 2564 M 2565 M 2566 M 2567	2 nd decade (lsb) 2 nd decade 2 nd decade 2 nd decade (msb)	
M 2568 M 2569 M 2570 M 2571	3 rd decade (lsb) 3 rd decade 3 rd decade 3 rd decade (msb)	
M 2572 M 2573 M 2574 M 2575	4 th decade (lsb) 4 th decade 4 th decade 4 th decade (msb)	
M 2576	Sign	

Markers 2816, 2817 and 2818 determine to which Q-parameter (Q 100 to Q 107) the numerical value should be assigned.

2816	0	1	0	1	0	1	0	1
2817	0	0	1	1	0	0	1	1
2818	0	0	0	0	1	1	1	1
Parameter	Q 100	Q 101	Q 102	Q 103	Q 104	Q 105	Q 106	Q 107

Transfer of the numerical value is effected by setting the marker 2809 if an M, S or T-function has been output.

C 2.2.10) Markers for touch probe system

Marker No.	Function	Signal direction
2503	Release marker for touch probe system	PLC → NC

As of software version 02

Marker No.	Function	Signal direction
2023	Stylus already deflected when starting probing cycle	NC → PLC
2024	Touch probe system ready (TS 511)	
2025	Stylus was deflected	
2026	Probing function executed	
2027	Battery voltage too low (TS 511)	

Marker 2503 is reset by the NC-part of the control, if a probing function has been started. The control waits before execution of the probing function until the PLC has reset the marker 2503.

For instance, this marker can suppress the beginning of a measuring procedure if the spindle has not been cleaned with compressed air prior to insertion of the touch probe.

If the touch probe stylus is deflected prior to starting a probing cycle, marker 2023 is set by the NC-part of the control.

If the stylus is deflected during a probing procedure, marker 2025 is set. If the probing procedure is completed (touch probe has returned to the safety clearance), marker 2026 is set. Marker 2026 is also set if

.an error message has interrupted the probing procedure or
 .the probing procedure has been interrupted by pressing the external STOP-button.

For TS 511 there is an additional markers 2024 for the message "Touch probe system ready" and 2027 in the event of insufficient battery power. The marker 2024 is logically "1" if the touch probe is not ready after starting a probe cycle. The marker 2027 is logically "1" if the battery voltage is too low.

C 2.2.11) Macro-programs

The TNC 151/TNC 155 can be equipped for customer-specific macro-programs e.g. for aiding a toolchanger with random selection code. If the present PLC-memory capacity is insufficient, up to 300 PLC-commands can also be accommodated in a macro.

The following markers are available for the call-up of macro-programs:

Marker No.	Function	Signal direction
3264	Customer-specific macro 1	PLC → NC
3265	Customer-specific macro 2	
3266	Customer-specific macro 3	
3267	Customer-specific macro 4	
3268	Customer-specific macro 5	
3269	Customer-specific macro 6	
3270	Customer-specific macro 7	
3271	Customer-specific macro 8	
3272	Customer-specific macro 9	
3273	Customer-specific macro 10	
3274	Customer-specific macro 11	
3275	Customer-specific macro 12	
3276	Customer-specific macro 13	
3277	Customer-specific macro 14	
3278	Customer-specific macro 15	
3279	Customer-specific macro 16	
2189	Undefined macro called-up	NC → PLC

Markers 3024 – 3199 are used for messages from the macro-programs to the PLC or vice versa. Entry values in the machine parameters 209 to 212 are transferred to the macros via the **markers 3200 – 3263**.

If PLC-functions are to be stored as macros, contact your nearest HEIDENHAIN sales office.

C 2.2.11.1) Macro-programs for supporting a toolchanger with pocket coding

C 2.2.11.1.1) Description of markers

Four macro-programs support the control of a toolchanger via special markers.

Macros are activated via the following markers:

M 3264	BCD-Dual conversion of tool number or pocket number
M 3265	Increase the actual value of pocket number
M 3266	Decrease the actual value of pocket number
M 3267	Actual/nominal value comparison of pocket number

If a macro is called which is not defined, the error message:

“error in PLC program Q” appears.

The following additional markers are also required:

Markers for nominal values of pocket numbers:

M 3024	1 st bit (lsb)
M 3025	2 nd bit
M 3026	3 rd bit
M 3027	4 th bit
M 3028	5 th bit
M 3029	6 th bit
M 3030	7 th bit
M 3031	8 th bit (msb)

Markers for actual values of pocket numbers:

M 3032	1 st bit (lsb)
M 3033	2 nd bit
M 3034	3 rd bit
M 3035	4 th bit
M 3036	5 th bit
M 3037	6 th bit
M 3038	7 th bit
M 3039	8 th bit (msb)

Interrogation markers

M 3040	"1" if actual value = nominal value
M 3041	"1" if distance between pocket number actual/nominal value is less or equal to distance for speed reduction (machine parameter 209)
M 3042	"1" if the shortest distance from pocket number actual value to nominal value is positive (direction 1-2-3-4 etc.)
M 3043	"1" if T-code (M 2032 – M 2039) = 0
M 3044	"1" if T-code is greater than the max. pocket number (machine parameter 209)

C 2.2.11.1.2) Machine parameter 209

With machine parameter 209, the maximum number of tool magazine pockets and the distance to the speed reduction is determined.

The entry value is calculated as follows:

(Distance to speed reduction x 256) + max. number of magazine pockets = machine parameter 209

Example:

Number of magazine pockets = 36

Distance to speed reduction = 2 (places)

$$(2 \times 256) + 36 = 548$$

548 must be entered for machine parameter 209

C 2.2.11.1.3) Mechanical design of toolchanger magazine and functioning

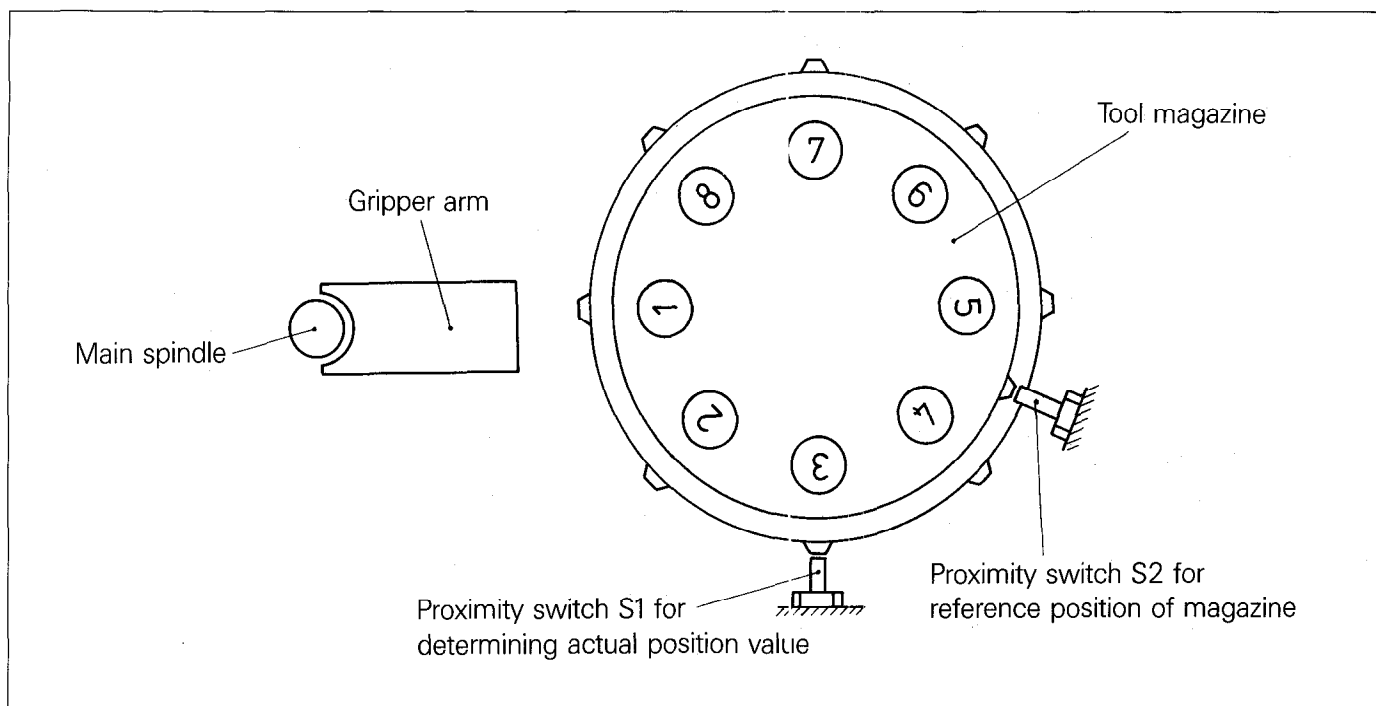

.With the first tool call, the tool magazine is rotated to the reference position (proximity switch S2). On reaching the proximity switch, the markers for the actual value of the pocket number (M 3032 to M 3039) is set.

.The tool number (T-code) in the markers M 2032 to M 2039 is converted BCD-to-dual by setting the marker M 3264 and transferred to the markers for the nominal value of the pocket number (M 3024 to M 3031). If marker M 3264 is set, the nominal and actual values are compared and the interrogation markers M 3043 and M 3044 are automatically set by the PLC.

If the T-code = 0, M 3043 is set to "1"

If the T-code is greater than the maximum value, M 3044 is set to "1".

Interrogation markers can be further linked within the PLC-program.

T-code = 0 means that no tool is to be searched for, since the tool call with number 0 only eliminates **tool compensation**.

If the T-code is greater than the maximum value, an error message can e.g. be displayed.

Please note:

Markers M 3043 and M 3044 are **not automatically reset**.

Reset must take place within the PLC-program.

.By setting the marker M 3267, the actual value (M 3032 to M 3039) of the tool position is compared with the nominal value (M 3024 to M 3031).

.If the actual value = nominal value, M 3040 is set to "1".

.If the distance actual/nominal value is less than or equal to the distance to the speed reduction, marker M 3041 is set to "1".

.If the shorter distance from actual-to-nominal value is positive (direction 1 – 2), marker M 3042 is set to "1".

.If the direction of rotation is defined (marker M 3042), the tool which is called-up can be searched for via the shortest distance.

The actual value of the magazine position can assume the values 1, 2, 3, 4 ... maximum value.

Depending on the rotation direction of the magazine, the actual value of the magazine position after every signal of the proximity switch S1 must be either increased by one value or reduced by one value.

Increase actual value: set marker M 3265!

New actual value = old actual value + 1, if the actual value is less than the maximum value.

New actual value = 1, if the actual value is greater or equal to the maximum value.

Decrease actual value: Set marker M 3266!

New actual value = old actual value - 1, if the actual value is greater than 1.

New actual value = Maximum value, if actual value = 1.

Please note:

Markers M 3265 and M 3266 may only be set for the duration of one PLC-cycle.

If several PLC-cycles have been set to the markers M 3265 or M 3266, each cycle will be increased or decreased.

.If the distance actual value/nominal value is less than or equal to the distance to the speed reduction (i. e. marker M 3041 = 1), the rotation speed of the magazine must be reduced.

.If the actual value = nominal value of the magazine position (i. e. marker M 3040 = 1), the magazine has to be stopped. The tool called-up, is in the changing position.

C 2.2.11.1.4) Overview of markers for supporting a toolchanger

Marker No. for macro- activation	Description	Function
M 3264	Tool-No. or pocket No. BCD-dual conversion	Tool No. (Pocket No.) (T-code) in M 2032 ... M 2039 Nominal value in M 3024 ... M 3031 the tool No. (Pocket No.) (BCD) is converted BCD-dual and transferred to the nominal value – if T-code = 0, M 3043 set to "1" – if T-code greater than max. value, M 3044 is set to "1"
M 3265	Increase actual value	The actual value (M 3032 ... M 3039) can assume the values 1, 2 ... max. value. – actual value + 1, if actual value is less than maximal value – actual value = 1, if actual value greater than or equal to max. value
M 3266	Decrease actual value	The actual value (M 3032 ... M 3039) can assume the values 1, 2 ... max. value. – actual value – 1, if actual value greater than 1 – actual value = max. value, if actual value = 1
M 3267	Actual/Nominal value comparison	Actual value in M 3032 ... M 3039 Nominal value in M 3024 ... M 3031 – if actual value = nominal value, M 3040 is set to "1" – if distance actual/nominal value less than or equal to distance to speed reduction, M 3041 is set to "1" – if the shorter distance from actual-to-nominal distance is positive, (direction 1-2), M 3042 is set to "1"

C 2.2.12) Marker for switching from X, Y or Z axis to the 4th axis

Marker No.	Function	Signal direction
2526	Changing the X-, Y- or Z axis onto the fourth axis. Markers 2590 and 2591 determine the changed axis.	PLC → NC
2542	Complement marker for marker 2526	
2590 2591	Determination of the axis that is to be changed onto the fourth axis	PLC → NC

With the markers 2526, 2542, 2590 and 2591 the axes X, Y and Z can be changed for processing onto the fourth axis.

The axis that is to be changed is determined via markers 2590 and 2591 as follows

2590	2591	Axis
0	0	X- axis
0	1	Y- axis
1	0	Z- axis
1	1	4 th axis

After the markers 2590 and 2591 are set the change is executed with markers 2526 and 2542 (complement). If for example in a program the position nominal values for the Y-axis are to be processed with the fourth axis, then the markers are to be set as follows:

Marker 2590 = 0 and
Marker 2591 = 1.

The change is activated through

Marker 2526 = 1 and
Marker 2542 = 0.

The NC part of the control after a PLC run automatically sets

Marker 2526 = 0 and
Marker 2542 = 1,
but the change is retained.

If the change is to be reserved, then set

Marker 2590 = 1 and
Marker 2591 = 1.

The change can be reactivated through

Marker 2526 = 1 and
Marker 2542 = 0.

C 2.2.13) Markers for activating the jog positioning

The jog positioning can be activated via the integrated PLC. In this way it is possible to additionally enter a step measure in the operating mode "electronic handwheel". When an axis direction key is pressed the corresponding axis moves by the distance entered.

(See also Operator's Handbook TNC 151/TNC 155 from December '87)

Marker No.	Function	Signal direction
2498	Activating jog positioning	PLC → NC
2512	X + Start marker	PLC → NC
2513	X - Start marker	
2514	Y + Start marker	
2515	Y - Start marker	
2516	Z + Start marker	
2517	Z - Start marker	
2518	IV + Start marker	
2519	IV - Start marker	
2528	X + Complement marker	PLC → NC
2529	X - Complement marker	
2530	Y + Complement marker	
2531	Y - Complement marker	
2532	Z + Complement marker	
2533	Z - Complement marker	
2534	IV + Complement marker	
2535	IV - Complement marker	

C 2.2.14) Markers for determining axis sequence upon approaching the reference marks

Marker No.	Function	Signal direction
2602	If the marker is set, the reference marks will be approached in the sequence set by markers 2603–2607. If it is reset, the sequence is as defined in MP 59.	PLC → NC
2603	Axis sequence for approaching the reference marks (lsb)	PLC → NC
2604	Axis sequence for approaching the reference marks	
2605	Axis sequence for approaching the reference marks	
2606	Axis sequence for approaching the reference marks	
2607	Axis sequence for approaching the reference marks (msb)	

The markers 2603 to 2607 determine the axis sequence upon approaching the reference marks:

2607	2606	2605	2604	2603	Axis sequence	Signal direction
0	0	0	0	0	X Y Z IV	PLC → NC
0	0	0	0	1	X Y IV Z	
0	0	0	1	0	X Z Y IV	
0	0	0	1	1	X Z IV Y	
0	0	1	0	0	X IV Y Z	
0	0	1	0	1	X IV Z Y	
0	0	1	1	0	Y X Z IV	PLC → NC
0	0	1	1	1	Y X IV Z	
0	1	0	0	0	Y Z X IV	
0	1	0	0	1	Y Z IV X	
0	1	0	1	0	Y IV X Z	
0	1	0	1	1	Y IV Z X	
0	1	1	0	0	Z X Y IV	PLC → NC
0	1	1	0	1	Z X IV Y	
0	1	1	1	0	Z Y X IV	
0	1	1	1	1	Z Y IV X	
1	0	0	0	0	Z IV X Y	
1	0	0	0	1	Z IV Y X	
1	0	0	1	0	IV X Y Z	PLC → NC
1	0	0	1	1	IV X Z Y	
1	0	1	0	0	IV Y X Z	
1	0	1	0	1	IV Y Z X	
1	0	1	1	0	IV Z X Y	
1	0	1	1	1	IV Z Y X	

C 2.2.15) Other markers

C 2.2.15.1) Markers for the first PLC-program cycle after power on and after interruption of PLC-program

Marker No.	Function	Signal direction
2180	1. PLC-program cycle after a power on (after cancellation of the error message "Power interrupted" by pressing CE)	NC → PLC
2185	1. PLC-program cycle after interruption of PLC-program (if MP 77 = 0 and the "PLC editing function" is left)	

Marker 2180 is set at logic "1" only during the first PLC-program-cycle after a power on. This also applies to Marker 2185 during the first PLC-program-cycle after an interruption of the PLC-program.

Marker No.	Function	Signal direction
2006	When output of spindle slewing speed is analog, this marker is set if a certain slewing speed is exceeded or not attained 1 = given slewing speed not attained 0 = given slewing speed exceeded	NC → PLC

If the marker 2006 is to be used, then there are only four gear train levels available for the analog output of the spindle slewing speed. The gear train levels are defined via machine parameter 78...81.

The entry values in machine parameters 82...85 must be smaller than the entry values in machine parameters 78...81. If within one gear train level (machine parameters 78...81) the associated value in machine parameters 82...85 is not reached, then marker 2006 is set.

If the entry values in machine parameters 82...85 are greater than the entry values in machine parameters 78...81, then these entry values are considered gear train levels and marker 2006 is not set.

Merker No.	Function	Signal direction
2062	If the dialog "key number" is displayed, the marker is set.	NC → PLC
2063	If the program No. 0 (central tool memory) is addressed, the marker will be set.	
2092	If the dialog "wrong speed" is displayed, the marker is set.	
2504	When operating with axis clamping with continuous contour transition in the subsequent block, a stationary axis will be clamped, if the marker is set.	PLC → NC
2508	"1" ≙ Status display M08 "0" ≙ Status display M09 Example for the status display of the auxiliary functions: M5/9	NC → PLC PLC → NC
2501	With analog output of the spindle slewing speed, the slewing speed determined in machine parameter 258 is issued if the marker is set.	PLC → NC
2511	Feed rate override is not effective if the marker is set.	PLC → NC

C 2.2.15.2) Markers affected by machine parameters

Markers can be set or reset via machine parameters 158, 249 and 250. The contents of these markers are utilised to activate various PLC-program routines. It is therefore possible to employ one PLC-program for various machines. In the event, for example, that machines of a particular series are fitted with different gear ranges, a common PLC-program can be employed for these machines. The different PLC-program routines for the decoding the gear ranges are selected by appropriate entry values in the machine parameters.

The values of the markers which are to be set for a machine are simply added and the resultant numerical value is entered as a machine parameter.

Machine parameter 158

Marker No.	Function	Signal direction
2192	Value 1	NC → PLC
2193	Value 2	
2194	Value 4	
2195	Value 8	
2196	Value 16	
2197	Value 32	
2198	Value 64	
2199	Value 128	
2200	Value 256	
2201	Value 512	
2202	Value 1024	
2203	Value 2048	
2204	Value 4096	
2205	Value 8192	
2206	Value 16384	
2207	Value 32768	

Machine parameter 249

Marker No.	Function	Signal direction
2208	Value 1	NC → PLC
2209	Value 2	
2210	Value 4	
2211	Value 8	
2212	Value 16	
2213	Value 32	
2214	Value 64	
2215	Value 128	
2216	Value 256	
2217	Value 512	
2218	Value 1024	
2219	Value 2048	
2220	Value 4096	
2221	Value 8192	
2222	Value 16384	
2223	Value 32768	

Machine parameter 250

Marker No.	Function	Signal direction
2224	Value 1	NC → PLC
2225	Value 2	
2226	Value 4	
2227	Value 8	
2228	Value 16	
2229	Value 32	
2230	Value 64	
2231	Value 128	
2232	Value 256	
2233	Value 512	
2234	Value 1024	
2235	Value 2048	
2236	Value 4096	
2237	Value 8192	
2238	Value 16384	
2239	Value 32768	

Example:

The marker 2193, 2199 and 2206 should be set. The entry value for machine parameter 158 is established as follows:

Marker No. 2193: Value 2
Marker No. 2199: Value 128
Marker No. 2206: Value 16384
Entry value 16514

Note:

These markers should not be set in the PLC-program. Setting and resetting should, without exception, take place via machine parameter 158.

C 2.2.15.3) Dialogue language selectable via machine parameter 92

Via machine parameter 92 it can be selected whether the first dialog language (German, French, Italian, Spanish, Swedish, Finnish, or Dutch) or the second dialog language (English) should be active. If the English dialog language is addressed then marker 2041 is set.

Marker No.	Function	Signal direction
2041	English dialogue language is addressed	NC → PLC

C 2.2.15.4) Release of user-cycles

User-cycles can be activated or inhibited via markers 2240 to 2271.

Marker No.	Function	Signal direction
2240	User cycle 68	PLC → NC
2241	User cycle 69	
2242	User cycle 70	
2243	User cycle 71	
2244	User cycle 72	
2245	User cycle 73	
2246	User cycle 74	
2247	User cycle 75	
2248	User cycle 76	
2249	User cycle 77	
2250	User cycle 78	
2251	User cycle 79	
2252	User cycle 80	
2253	User cycle 81	
2254	User cycle 82	
2255	User cycle 83	
2256	User cycle 84	
2257	User cycle 85	
2258	User cycle 86	
2259	User cycle 87	
2260	User cycle 88	
2261	User cycle 89	
2262	User cycle 90	
2263	User cycle 91	
2264	User cycle 92	
2265	User cycle 93	
2266	User cycle 94	
2267	User cycle 95	
2268	User cycle 96	
2269	User cycle 97	
2270	User cycle 98	
2271	User cycle 99	

User-cycles are inhibited by setting the appropriate markers.

C 2.2.15.5) Marker for tapping cycle

Marker No.	Function	Signal direction
2048	Tapping cycle is called-up	NC → PLC

If the tapping cycle is called, "1" is set for marker 2048.

C 2.3) PLC-Inputs and PLC-Outputs: Address letters E, A

Note:

Before each PLC-cycle, all inputs are read-in and stored for further processing; the outputs are outputted after the complete program run. Refer to section B 2.3 for technical data on in- and outputs.

Technical data of inputs and outputs, see section B 2.3.

C 2.3.1) Overview

The following inputs and outputs are available:

Address	Meaning
E0 – E62 E63	PLC-inputs on the first PLC-board, internally wired on the first PLC-board
E64 – E126 E127	PLC-inputs on the second PLC-board, internally wired on the second PLC-board
PL 100 B	
A0 – A30 A31	PLC-outputs for first PLC-board, internally wired on the first PLC-board
A32 – A62 A63	PLC-outputs for second PLC-board, internally wired on the second PLC-board
PL 110 B	
A0 – A24 A25 – A30 A31	PLC-outputs on the first PLC-board, bipolar outputs on the first PLC-board internally wired on the first PLC-board
A32 – A56 A57 – A62 A63	PLC-outputs on the second PLC-board, bipolar outputs on the second PLC-board internally wired on the second PLC-board

The following inputs and outputs are reserved and cannot be freely allocated:

Input	Function
E0 E1 E2 E3	Reference End Position X Reference End Position Y Reference End Position Z Reference End Position IV
E4 E5 E6 E7	Reference Pulse Inhibit X Reference Pulse Inhibit Y Reference Pulse Inhibit Z Reference Pulse Inhibit IV
E8	Feedback Emergency Stop
E63	Overload of a PLC-output stage on the first PLC-board (internally wired)
E127	Overload of a PLC-output stage on the second PLC-board (internally wired)
Output	
A31 A63	Cancellation of the "overload-condition" on the first PLC-board (internally wired) Cancellation of the "overload-condition" on the second PLC-board (internally wired)

Note:

Input E8 "Feedback Emergency Stop"!

The NC-part of the TNC receives this signal direct from input E8, it is not processed by the PLC.

Nevertheless, the status of the feedback can be interrogated in the PLC-program.

C 2.3.2) Bipolar PLC-outputs for PL 110 B

The PLC-input/output board PL 110 B is equipped with bipolar output stages for the control of D.C. motors. The following output pairs are on the first PLC-board:

A25, A26
A27, A28
A29, A30

On the second PLC-board:

A57, A58
A59, A60
A61, A62

The programming is achieved as follows:
for the output stages A25, A26

Output A25 set	→	Output A25 + 15 V
Output A26 reset	→	Output A26 0 V
Output A25 reset	→	Output A25 0 V
Output A26 set	→	Output A26 + 15 V

Circuit example:

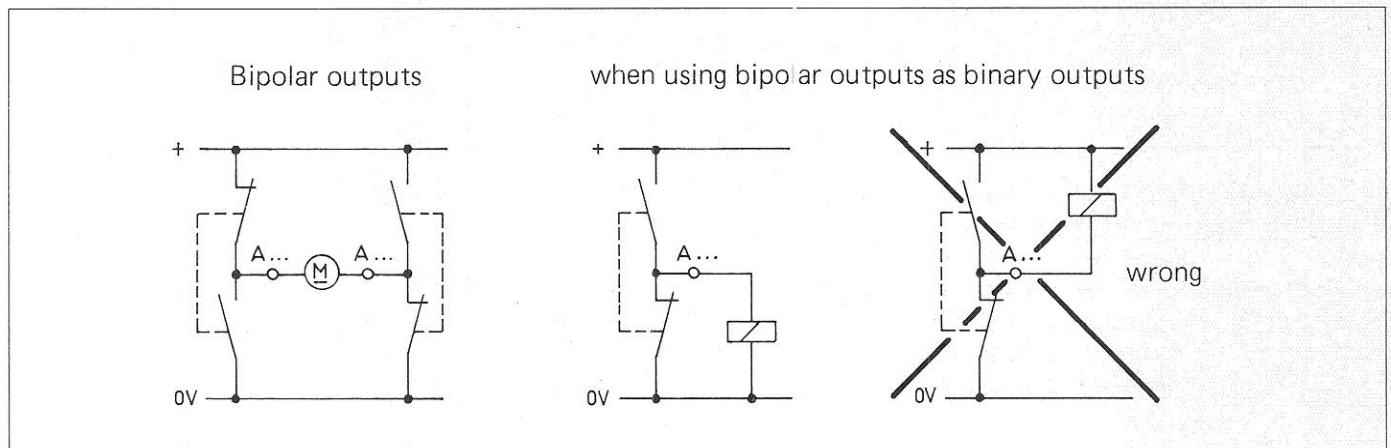

Output overcurrent protection for the bipolar outputs

The output for the overcurrent protection is set to logic "1" if the summation of the three bipolar output currents exceeds 0.8 – 0.9 A. This signal cannot be directly interrogated via the PLC. For the overcurrent protection to be evaluated, this output should be connected to a PLC-input.

Note:

Reaching the current limit of 0.8 – 0.9 A indicates no error message! This signal must be processed according to requirements.

C 2.3.3) Output "Emergency Stop"

The internal "Emergency Stop" signal is not processed by the PLC. The output is set directly by the NC-part of the control in order to minimise any delay.

The sequence of the emergency stop routine on powering up the control (i.e. checking the emergency stop contact with the aid of the input E8 "Feedback Emergency Stop") is described in the interface description. These monitoring routines must not be implemented in the PLC-programme, as the signal from the input E8 is interrogated directly by the NC-part of the control.

Note:

If two PLC-boards are connected to a control, it is sufficient when the "emergency stop" output and the "Feedback signal emergency stop" input are wired on board.

C 3) Counters

The PLC has 16 counters at its disposal, each of the 16 counters being controlled through two special markers with the identification Z. Whether or not the counter status has reached "0" can be interrogated by the use of an additional marker, also represented by the identification Z. The counter is set to the entry value programmed in the corresponding machine parameter (max. 65535) and counts backwards to the counter status "0". The counter is decremented by 1 with every cycle of the PLC-programme (20 ms).

Function	Marker identification	Remarks
Set Counter	Z0 – Z15	Through the assignment of a logic "1", the corresponding counter will be set to the preset value in the machine parameter. The assignment of the logic "1" must only exist for one PLC cycle, otherwise the setting will be repeated at each subsequent cycle.
Counter not equal to "0"	Z48 – Z63	The marker Z48 – Z63 corresponding to the counter Z0 to Z15 is at logic "1" when a counter has been set. The counter has been set. The counter status can be interrogated via Z48 to Z63. On reaching the counter status "0" the marker for the counter status is set again to logic "0". Note: For the duration of the first program cycle after the setting of the counter, the corresponding marker Z48 to Z63 remains at logic "0".
Counter impulse-release	Z96 – Z111	The counter will be decremented by "1" if the corresponding marker has a logic state "1" at the end of a PLC-cycle. In the event of the corresponding marker having a logic state "0" at the end of a PLC-cycle, no decrement occurs.

Impulse diagram

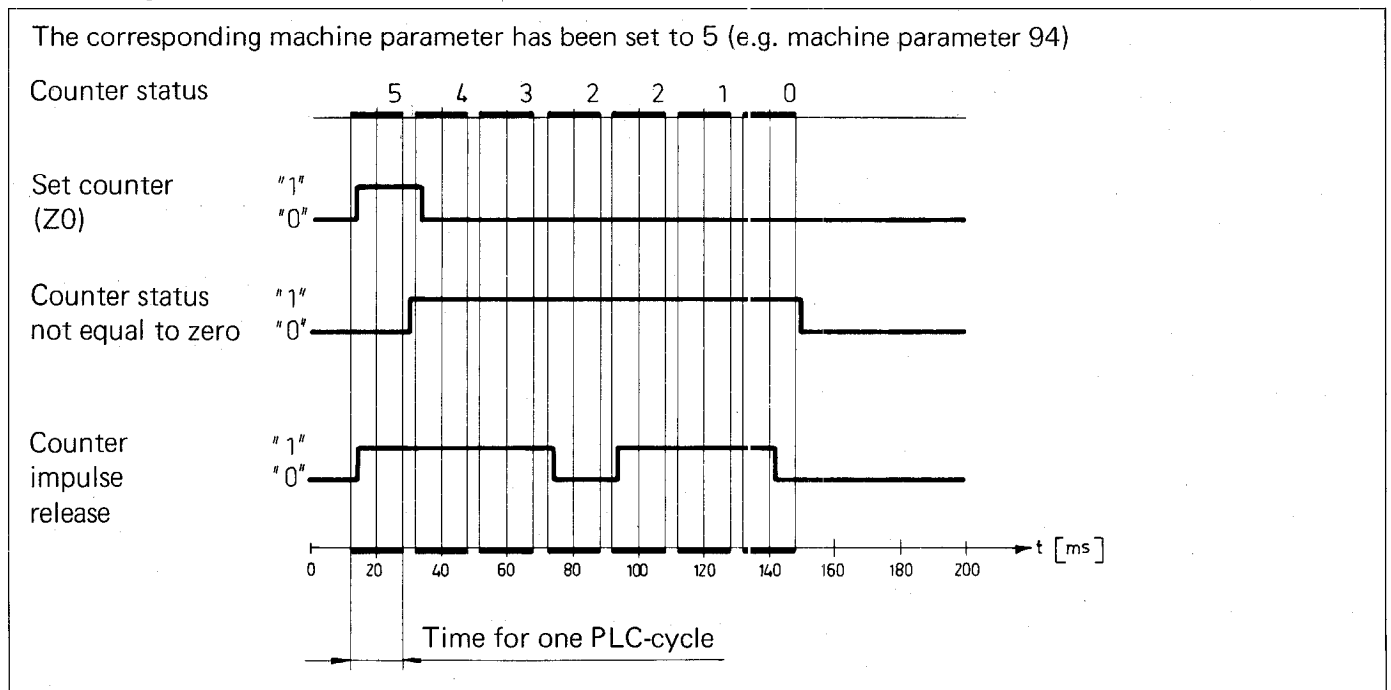

Relationship of the counter-markers to the machine parameters

Set counter	Z0	Z1	Z2	Z3	Z4	Z5	Z6	Z7	Z8	Z9	Z10	Z11	Z12	Z13	Z14	Z15
Counterstatus not equal to "0"	Z48	Z49	Z50	Z51	Z52	Z53	Z54	Z55	Z56	Z57	Z58	Z59	Z60	Z61	Z62	Z63
Counter impulse release	Z96	Z97	Z98	Z99	Z100	Z101	Z102	Z103	Z104	Z105	Z106	Z107	Z108	Z109	Z110	Z111
Machine parameter for preset value	94	95	96	97	98	99	100	101	102	103	104	105	106	107	108	109

C 4) Timers

The PLC has 32 timers at its disposal. The start of each of the 32 timers is controlled by a special marker with the identification T. The timers time out from the times programmed in the corresponding machine parameters. The unit of time is 20 ms (max. 65535 units programmable). An additional special marker with the identification T enables "Timer running" to be interrogated.

Function	Marker identification	Remarks
Timer start	T0 to T31	Through the assignment of a logic "1", the corresponding timer will be set to the preset value in the associated machine parameter and started. The assignment of the logic "1" must only exist for one PLC cycle, otherwise the setting will be repeated on each subsequent program cycle.
Timer running	T48 to T79	The marker T48 to T79 corresponding to the timer T0 to T31 is at logic "1", when a Timer has been set. The status "Timer running" can be interrogated via T48 to T79. On the timing out of the timer, the marker "Timer running" is set again to logic "0". Note: For the duration of the first program cycle after the setting of the timer, the corresponding marker T48 to T79 remains at logic "0".

Impuls diagram

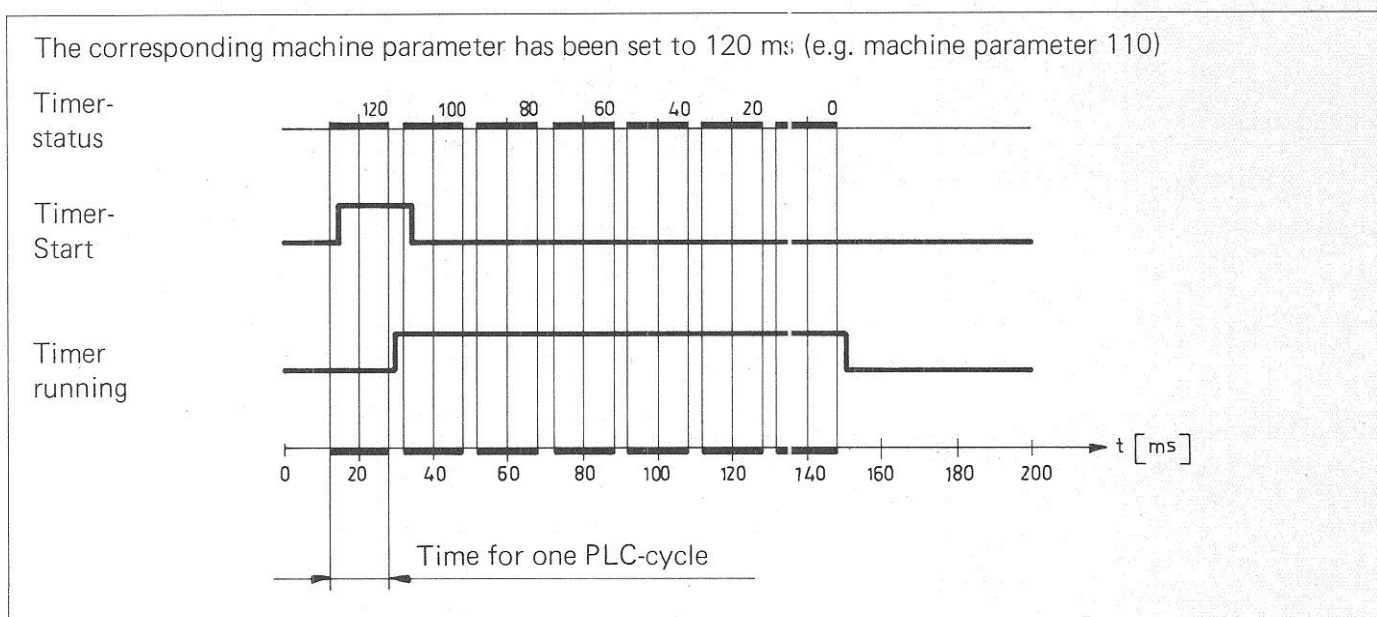

Relationship of the markers:

Timer start	T0	T1	T2	T3	T4	T5	T6	T7	T8	T9	T10	T11	T12	T13	T14	T15
Timer running	T48	T49	T50	T51	T52	T53	T54	T55	T56	T57	T58	T59	T60	T61	T62	T63
Machine parameter	110	111	112	113	114	115	116	117	118	119	120	121	122	123	124	125
Timer start	T16	T17	T18	T19	T20	T21	T22	T23	T24	T25	T26	T27	T28	T29	T30	T31
Timer running	T64	T65	T66	T67	T68	T69	T70	T71	T72	T73	T74	T75	T76	T77	T78	T79
Machine parameter	193	194	195	196	197	198	199	200	201	202	203	204	205	206	207	208

C 5) Selecting and exiting from the PLC-modes

The control offers the possibility of programming and the subsequent testing of the PLC program.

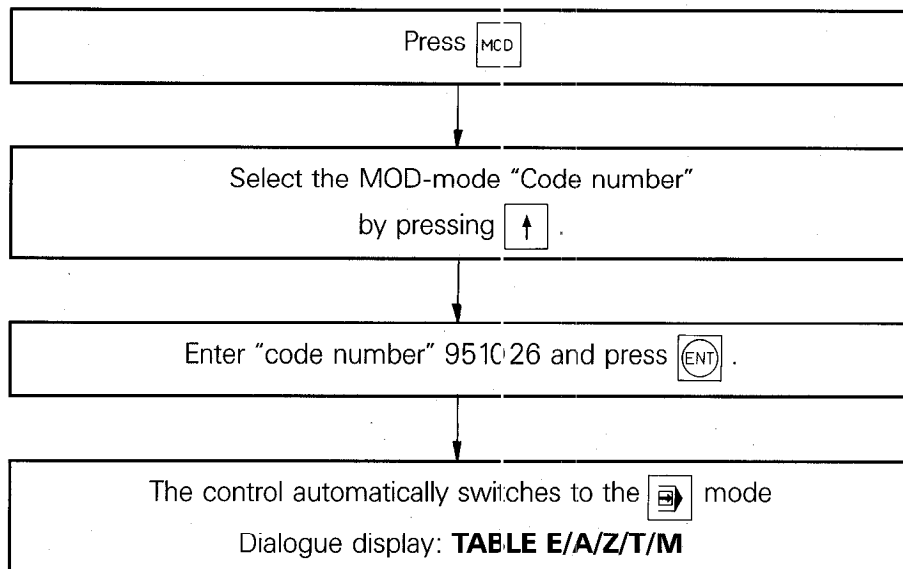

The modes buttons select the following PLC modes:

Button	Mode
≙ TAB	Table E/A/Z/T/M (see section C 5.3)
≙ PCT	PLC-Program "Trace" (see section C 5.2)
≙ PCE	PLC-Program "Editor" (see section C.5.1)

The PLC modes are exited by pressing

C 5.1) "PLC Program editor": button

Select the "PLC Program editor" mode with the button.

The VDU displays the following:

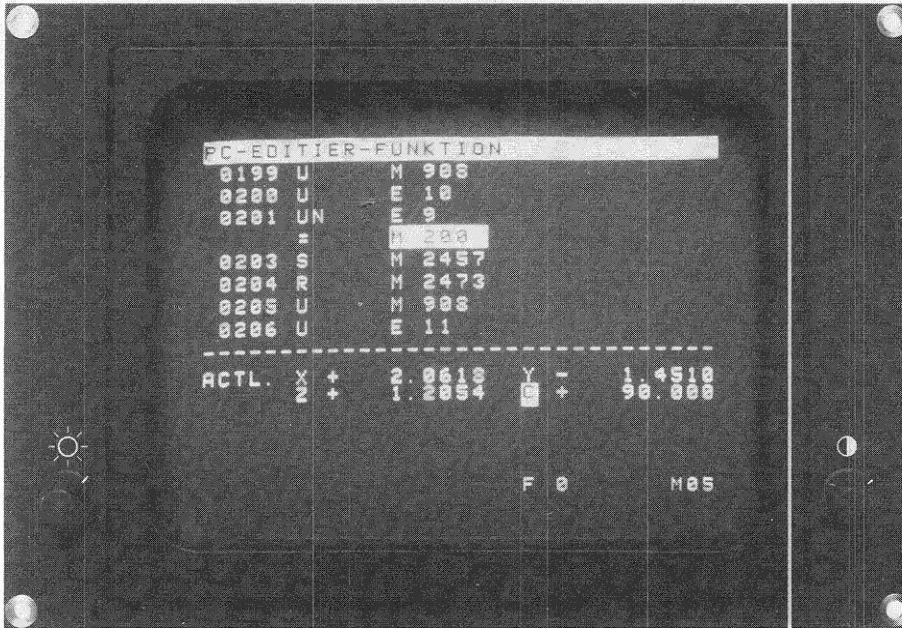

In this mode, the PLC-program can be compiled and edited. When compiling the PLC-program at the control, the PLC-program is stored internally in RAM (Random Access Memory).

A PLC-program can be copied from the control onto a ME 101/102 cassette, FE 401-floppy disc or directly into an EPROM programming unit. A master EPROM with the PLC-program is compiled by HEIDENHAIN from the magnetic tape containing the PLC-program.

Program administration is also carried out by HEIDENHAIN.

In the control, there is a socket provided for the EPROM. Machine parameter 77 selects whether the machine should utilise the PLC-program in RAM or EPROM.

For editing purposes, a program can be copied from EPROM into RAM.

Machine Parameter 77

Entered value 1: The PLC-program is stored in the EPROM area

Entered value 0: The PLC-program is stored in the RAM area.

Note:

The PLC-program in the RAM-memory is checked after control switch-on. An erroneous program is erased and the following error message is displayed:

PLC: PROGRAM MEMORY ERASED

C 5.1.1) Keyboard layout for PLC-programming

If the control mode "PLC program editor" is selected, some of the buttons on the front panel are assigned as PLC programming functions. A PLC-programming keyboard foil showing the appropriate button designations forms part of this manual.

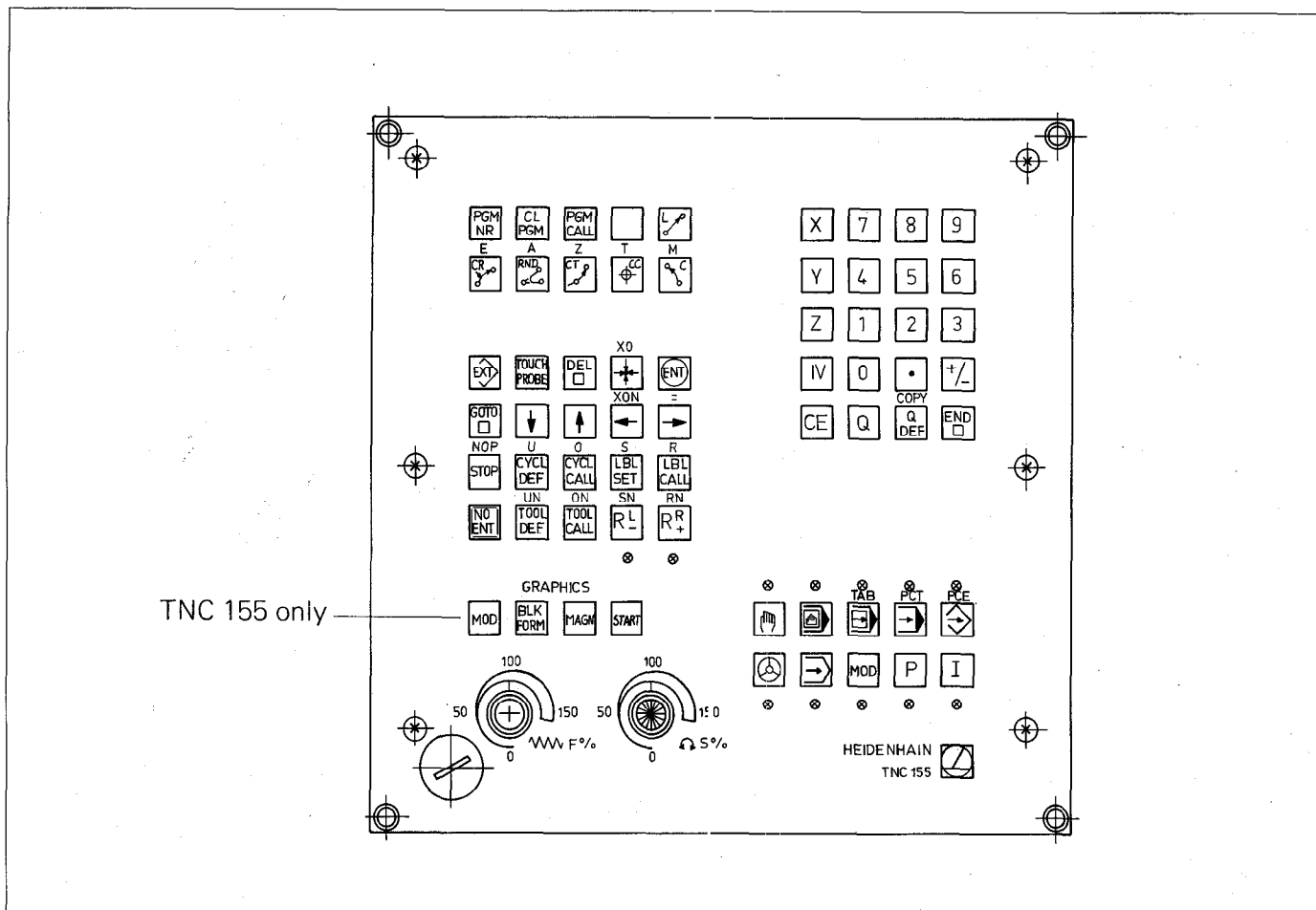

C 5.1.2) Button functions

TNC-Symbol	PLC-Symbol	PLC-Function	
		When is also pressed, the PLC-program is erased	
		Clears the actual PLC-command (VDU blank)	
		If an additional numeric value (0 ... 2047) and is pressed, the respective PLC-command is selected	
		Selects the following PLC-command	
		Selects the previous PLC-command	
		Transfers as necessary and available PLC-program (EPROM) into RAM after additional press of the -key.	
		Input/Output of PLC-programs to Cassette (ME) or printer	
		Exits from the PLC-editor into normal NC operation	
		Enters the PLC-command NOP.	
		The description of the PLC-commands can be found in section C 1	
			The following buttons provide the PLC commands with the operands. Terminate operand input with the button or by entering the next PLC-command.
			Input; plus the necessary numeric value (0 ... 125)
		Output; plus the necessary numeric value (0 ... 63)	
		Counter; plus the necessary numeric value (0 ... 15)	
		Timer; plus the necessary numeric value (0 ... 31)	
		Marker; plus the necessary numeric value (0 ... 3023)	

C 5.1.3) Programming PLC-commands

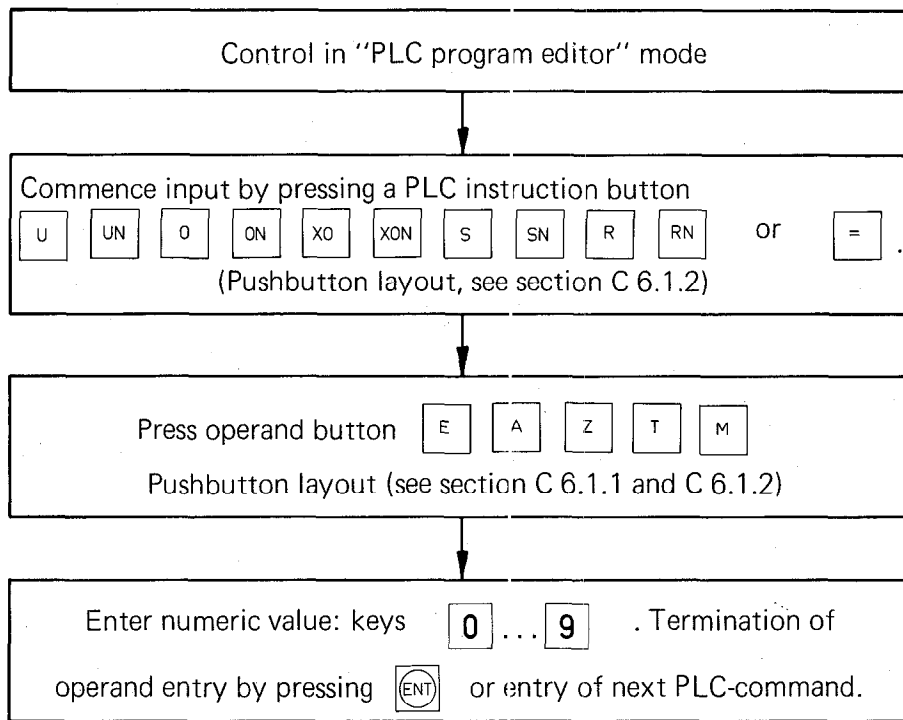

Programming the NOP PLC-command:  Press .

Note:

Free command lines are displayed on the VDU as NOP's.

C 5.1.4) Call-up of a specific PLC-command

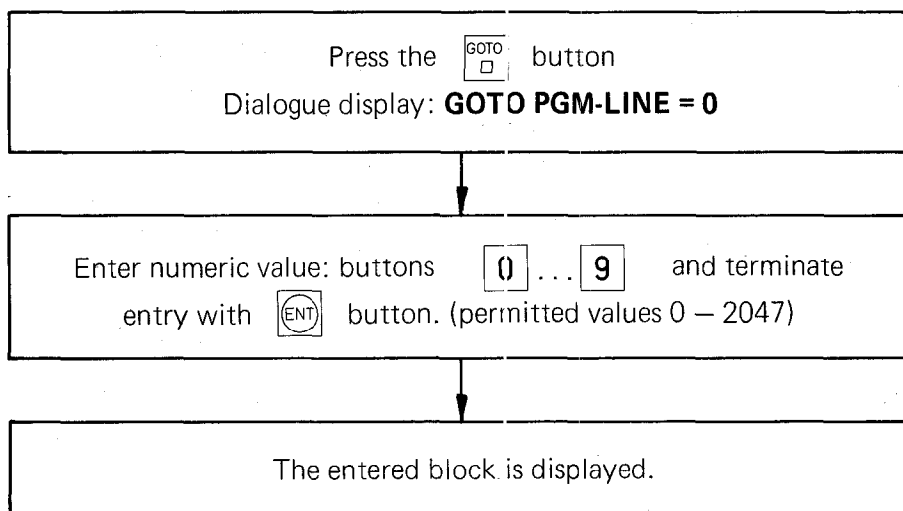

C 5.1.5) Sequential checking of PLC commands

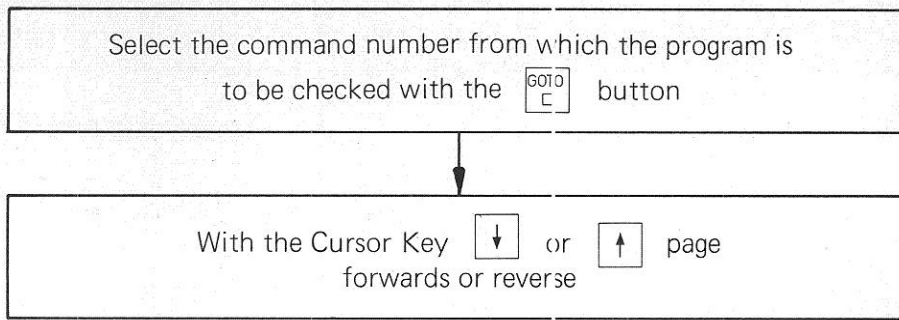

C 5.1.6) Deleting PLC-commands

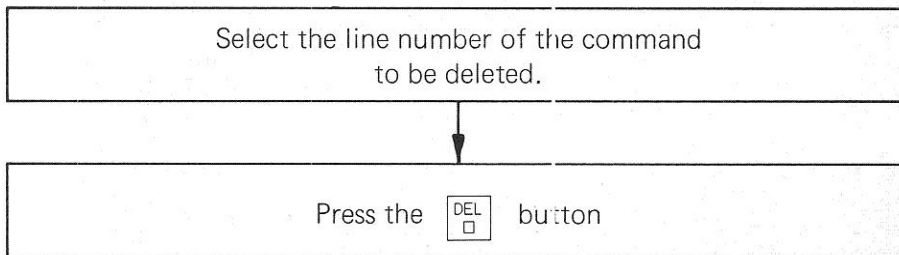

C 5.1.7) Entering PLC-commands into an existing program

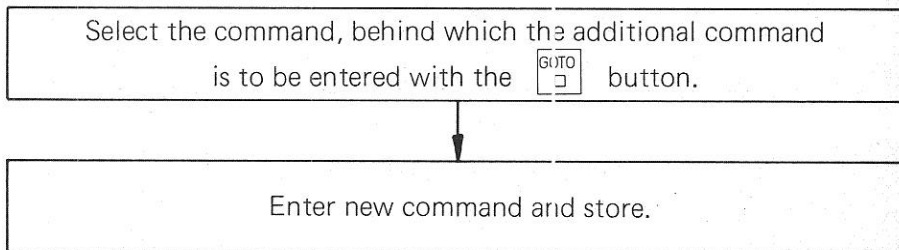

C 5.1.8) Deleting a PLC-Program

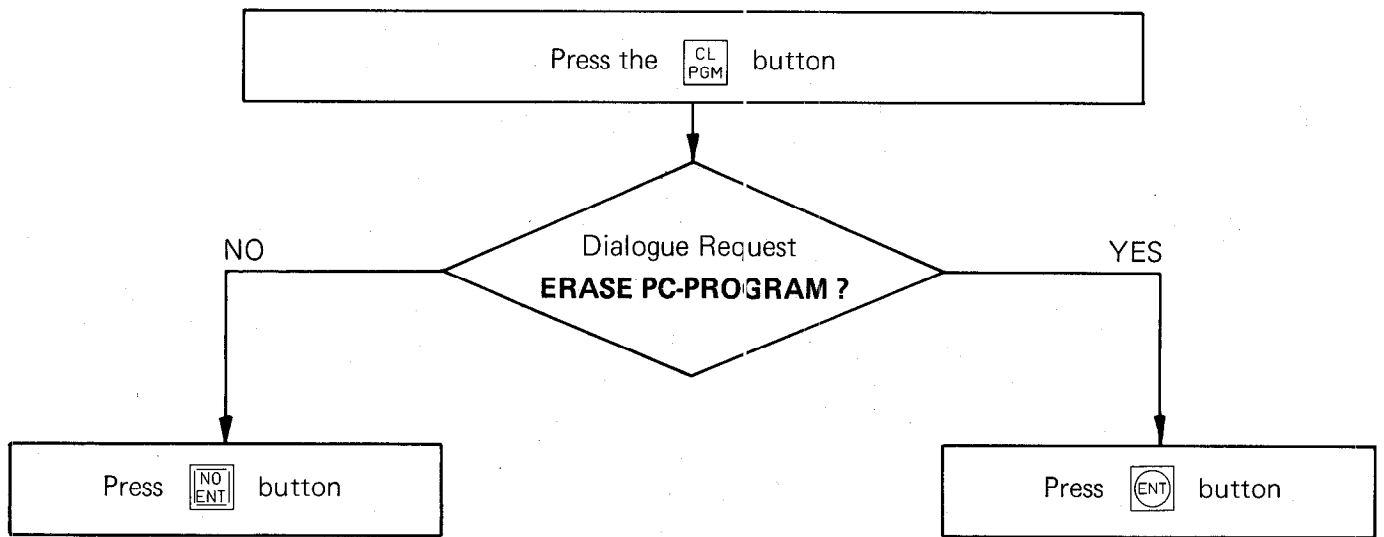

C 5.1.9) Transfer of a program from the main memory into the read/write-store

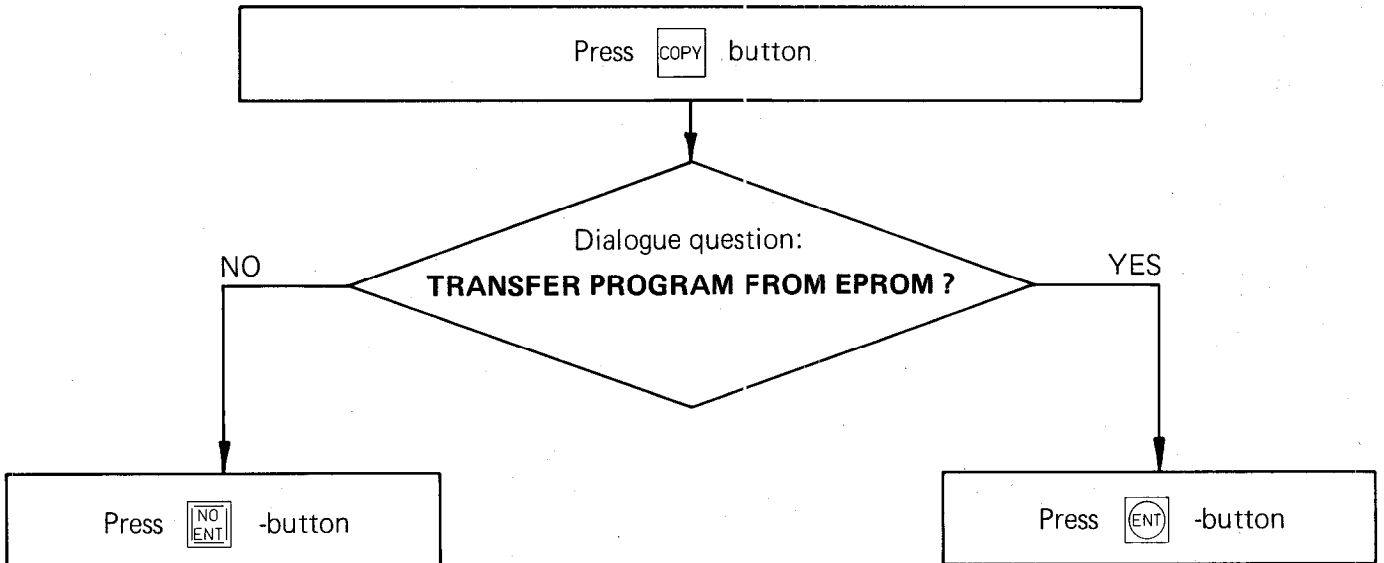

C 5.1.10) Input/Output of PLC-programs on magnetic tape or printer

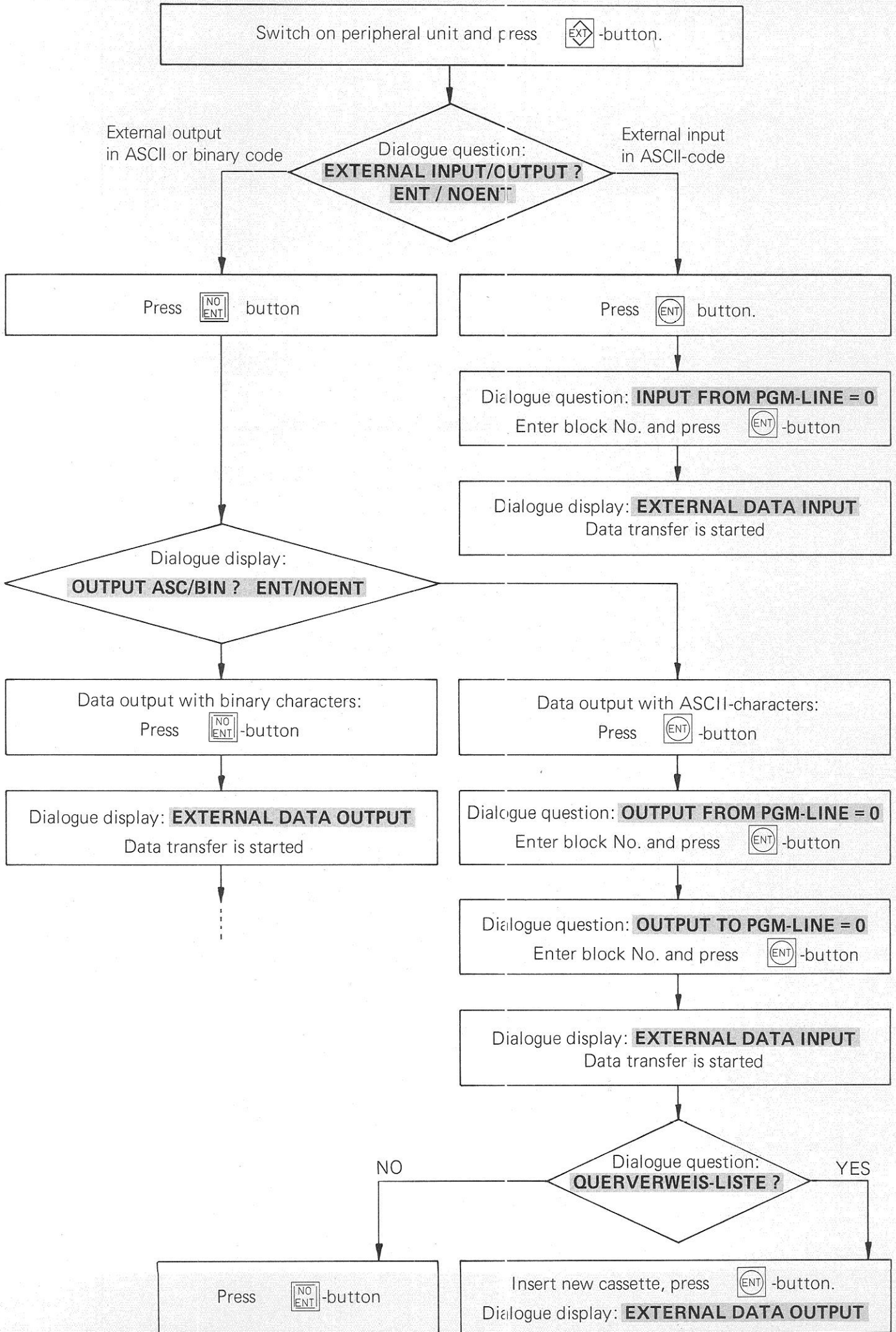

Binary output of user-cycles for compiling a PLC-EEPROM

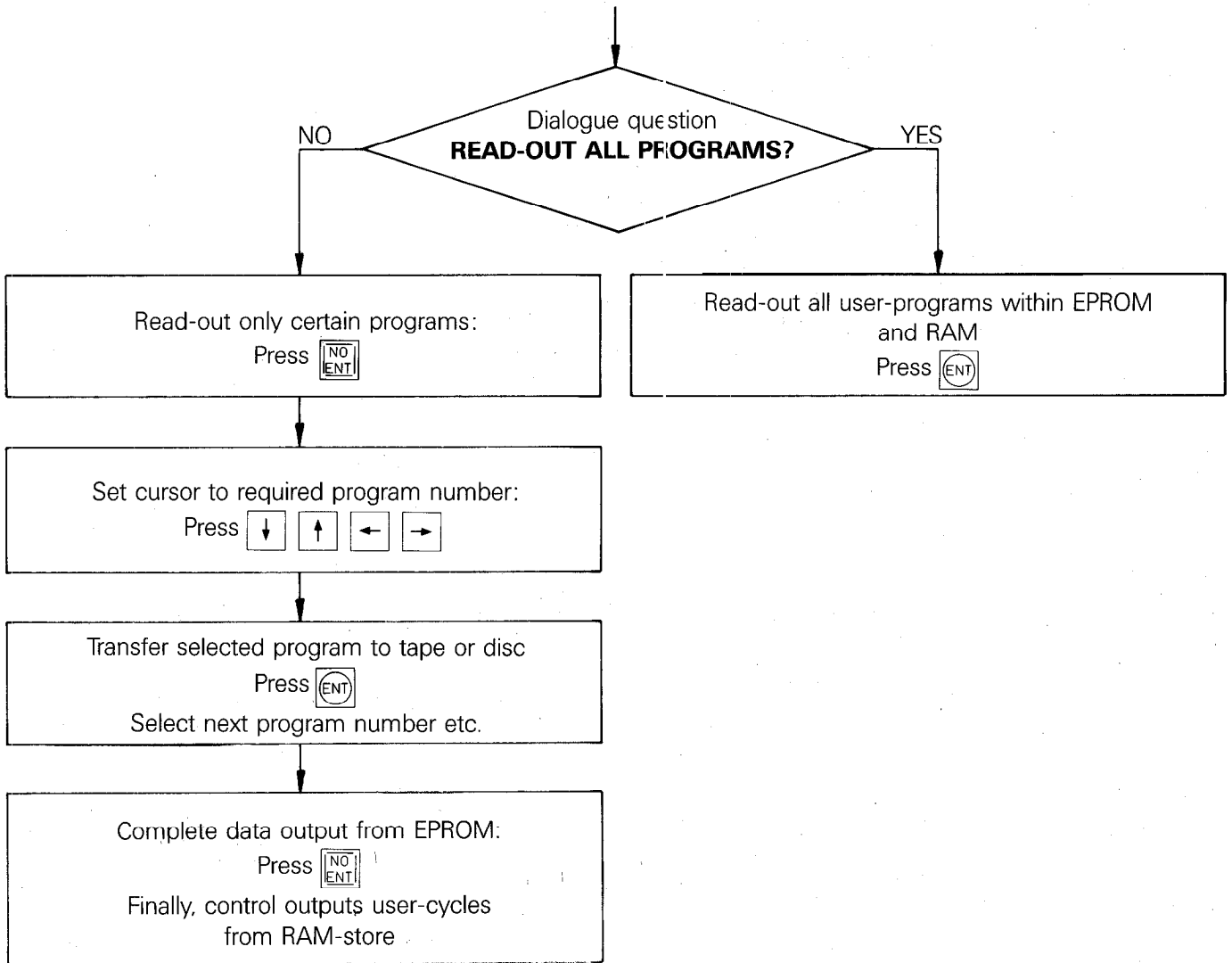

Please note:

With the aid of the HEIDENHAIN magnetic tape unit, floppy disc unit or another peripheral unit, program sections within the PLC-store can be shifted. For this, the program section to be shifted has to be read-out. With a new read-in, the program section is shifted to the command number which has been entered in response to the dialogue question "INPUT FROM PGM-LINE:=".

C 5.2) Operating mode "PLC-Program trace function": PCT-button

Operating mode selection "PLC-Program trace function" by the pressing the mode-key PCT (see section C 5).

The following display appears on the VDU:

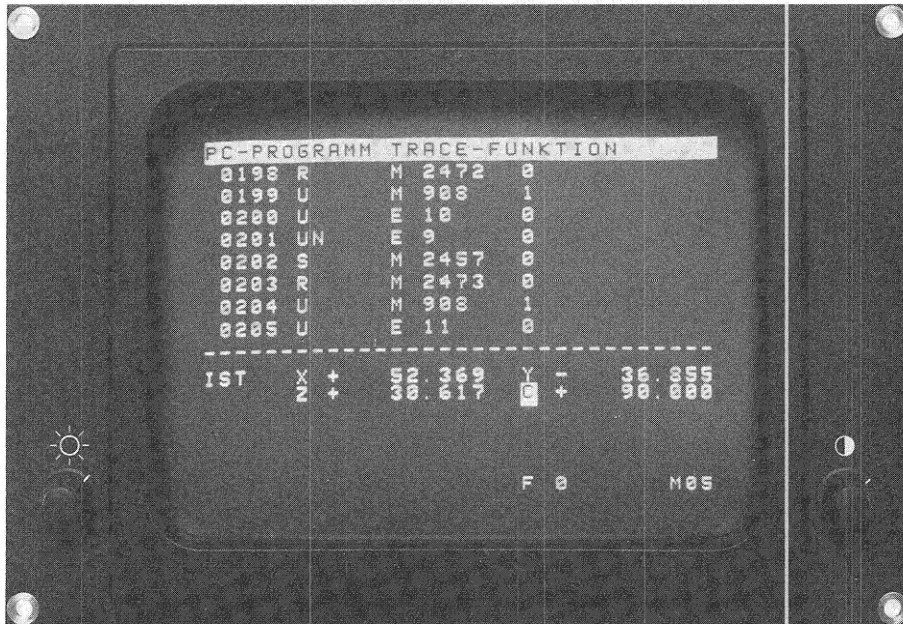

In this mode, the function of the PLC-program can be checked in the RAM-memory. In addition to the PLC-commands, the logic state of the operands and gating results are displayed. The logical status of a marker at input or output is displayed additionally before display of the gating result.

C 5.3) Operating mode "Table E/A/Z/T/M": -button

Select the "Operand display" mode by pressing the -button (see section C 6).

The VDU-display shows the following dialogue:

TABLE E/A/Z/T/M

By pressing the respective operand button, the states of all the

Inputs : -button

Outputs : -button

Counters : -button

Timers : -button

Markers : -button

are displayed on the VDU.

Note:

.If a change to some other display mode or operating mode from an operand display mode is required, first press the -button.

.The cursor buttons , and , enable a specified operand to be highlighted in inverse video on the VDU-display, in order that the logic state of an operand can be easily observed.

.Marker logic state display:

As only 120 markers can be displayed simultaneously, the -button and the entry of a numeric value selects some other marker range.

The VDU-displays the following (e.g. the logic input states)

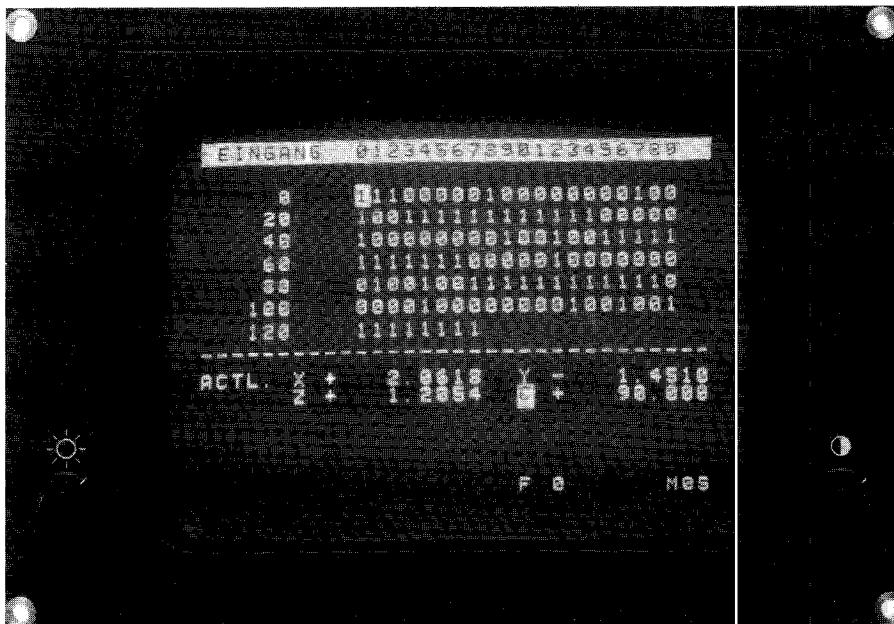

C 6) Off-line PLC-programming

An off-line programming terminal is not currently available from HEIDENHAIN. This section provides information as to the format of the PLC-commands so that off-line programming terminal suppliers can develop a terminal for the HEIDENHAIN-PLC if they so wish.

Note:

With external programming, comments following PLC-commands must be separated from the PLC-command by the character *;.

C 6.1) PLC-command format

Every PLC-command requires a 16 bit word i.e. 2 bytes are defined in the PLC-command memory. An command consists of a 4 bit PLC-operation code and the 12 bit PLC-address. The PLC-operation code defines the binary instruction and the PLC-address calls a memory location for the operands which are to be processed.

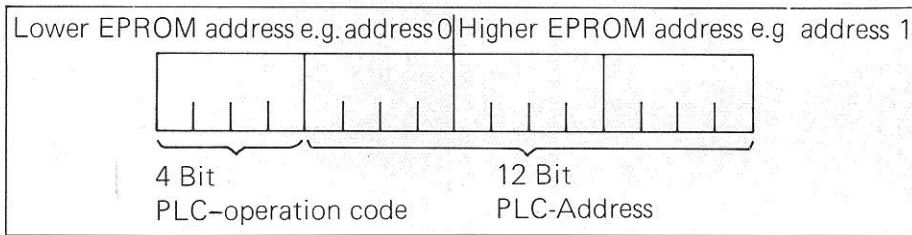

C 6.2) PLC-Operation codes for PLC-Commands

Abbreviation	PLC-Operation code
NOP	0000
U	0001
UN	0010
O	0011
ON	0100
XO	0101
XON	0110
S	0111
SN	1000
R	1001
RN	1010
=	1011
NOP	1111

C 6.3) PLC-Address for PLC-Commands

Abbreviation	PLC-Address (Hexadecimal)
M0 – M3279	000 – CCF
E0 – E127	CD0 – D4F
A0 – A63	E50 – E8F
Z0 – Z15	F10 – F1F
Z48 – Z63	F40 – F4F
Z96 – Z111	F70 – F7F
T0 – T31	FA0 – FBF
T48 – T79	FD0 – FEF

C 6.4) EPROM Address list

Addresses:

PLC-Operand	msb - PLC-Address	EPROM-Address 0
PLC-Address	lsb	EPROM-Address 1
PLC-Operand	msb - PLC-Address	EPROM-Address 2
PLC-Address	lsb	EPROM-Address 3
PLC-Operand	msb - PLC-Address	EPROM-Address 4
PLC-Address	lsb	EPROM-Address 5
PLC-Operand	msb - PLC-Address	EPROM-Address 4094
PLC-Address	lsb	EPROM-Address 4095
Internal PLC-software		
		Address 8191

C 6.5) Address allocation for PLC-EPROM

The PLC-program is permanently stored within an EPROM HN 27512.

Address allocation:

0000	4 K PLC-commands	
1000	B * R11	Assembler command: Return jump into main program
1002	Macro-table	Jump addresses for macro-programs
1042	Macros (assembler code)	ascending as of address 1042
	Macro (PLC-code)	descending as of address 1FFE
2000	Error messages	
2C80	Plain language dialogues for user cycles	
3900	PLC-software No.	
390C	2800 NC-Blocks	} Customized macros
FDEC	Directory 32 PGMs	
FFEC	vacant	
FFFE	CRC-sums	
FFFF		

D) Standard PLC-program description

The **TNC 151 B/TNC 155 B** control has interfacing has for an **external machine interface** (similar to the TNC 145 C). This interface is achieved by a PLC program.

The **TNC 151 Q/TNC 155 Q** control is supplied with an **external PLC-board**. The definition of the inputs the outputs and the specific PLC-program is defined by the machine tool builder.

In order to simplify the first commissioning of the TNC 151 Q/TNC 155 Q, the PLC-program for the TNC 151 B/TNC 155 B is programmed into the PLC program EPROM.

This program must be exchanged for the specific machine tool builders program.

The following description covers the standard PLC program 23460102

A comprehensive description of the new standard PLC program 23460104 is available from our customer service department in Traunreut.

D 1) Address list

Input address		Output address	
0	REF end position X	0	X axis enable
1	REF end position Y	1	Y axis enable
2	REF end position Z	2	X axis enable
3	REF end position IV	3	IV axis enable
4	REF impulse inhibit X	4	Control in operation
5	REF impulse inhibit Y	5	Control in automatic
6	REF impulse inhibit Z	6	Spindle on control
7	REF impulse inhibit IV	7	M-S-T code Bit 1
8	EMERGENCY Stop feedback	8	M-S-T code Bit 2
9	Direction button X+	9	M-S-T code Bit 3
10	Direction button X-	10	M-S-T code Bit 4
11	Direction button Y+	11	M-S-T code Bit 5
12	Direction button Y-	12	M-S-T code Bit 6
13	Direction button Z+	13	M-S-T code Bit 7
14	Direction button Z-	14	M-S-T code Bit 8
15	Direction button IV+	15	M03, spindle clockwise
16	Direction button IV-	16	M04, spindle counter clockwise
17	Miscellaneous function complete feedback	17	M05 spindle stop
18	Feed enable	18	M08, coolant on
19	Manual pressed	19	M09 coolant off
20	Internal link to output 6	20	G/S Strobe
21	Rapid button	21	M Strobe
22	Start button	22	T Strobe
23	Stop button		

Timers

10	G-M-S-T-output: strobe delay
11	G-M-S-T-output: strobe duration
12	G-M-S-T-output: delay for "auxiliary function complete"
13	Jog spindle CW
14	Jog spindle CCW
15	Delay feed enable (Positioning loop)

Marker List

900	"Programming" mode
901	"Manual" mode
902	"Electronic handwheel" mode
903	"Manual data input" mode
904	"Single block" mode
905	"Automatic" mode
908	"Manual" mode
909	"Control" mode
910	Buffer marker actual position value transfer – X axis
911	Buffer marker actual position value transfer – Y axis
912	Buffer marker actual position value transfer – Z axis
913	Buffer marker actual position value transfer – IV axis
917	Buffer marker manual pressed
919	Manual pressed
920	Buffer marker – start button
921	Buffer marker – rapid button
922	Buffer marker – M03 output
923	Buffer marker – M04 output
924	Buffer marker – M05 output
925	1st buffer marker G/S change signal
926	1st buffer marker M change signal
927	1st buffer marker T1 change signal
929	Buffer marker – Output 6
930	Buffer marker – M00
932	Buffer marker – M02
933	Buffer marker – M03
934	Buffer marker – M04
935	Buffer marker – M05
936	Buffer marker – M06
938	Buffer marker – M08
939	Buffer marker – M09
943	Buffer marker – M13
944	Buffer marker – M14
945	Buffer marker – M30
948	Buffer marker – M code-decade 0x
949	Buffer marker – M code-decade 1x
950	2nd Buffer marker – G/S change signal
951	2nd Buffer marker – M-change signal
952	2nd Buffer marker – T1 change signal
960	Buffer marker – gear range (0)
961	Buffer marker – gear range (1)
962	Buffer marker – gear range (2)
963	Buffer marker – gear range (3)
964	Buffer marker – gear range (4)
965	Buffer marker – gear range (5)
966	Buffer marker – gear range (6)
967	Buffer marker – gear range (7)
968	Buffer marker – T13 running
969	Buffer marker – T14 running

D 2) Reference listing for markers, inputs/outputs and timers:

This list shows which instructions use which markers, inputs/outputs and timers. For PLC-commands marked with * a signal is generated. With the remaining PLC-commands the signal is gated.

Marker Nos. — Used with PLC-command numbers:

M 0	*0000	0155	0156	0427	0428				
M 900	*0004	0025							
M 901	*0008	0026							
M 902	*0012	0027							
M 903	*0016	0029							
M 904	*0020	0030							
M 905	*0024	0031							
M 908	*0028	0064	0189	0197	0202	0207	0212	0217	
		0222	0227	0232					
M 909	*0032	0043	0063						
M 910	*0079	0092	*0096						
M 911	*0083	0097	*0101						
M 912	*0087	0102	*0106						
M 913	*0091	0107	*0111						
M 917	0067	*0070							
M 919	*0068	0071	0076	0080	0084	0088	0093	0098	
		0103	0108	0126	0129	0132	0135		
M 920	0182	*0194							
M 921	0186	*0196							
M 922	0061	*0360	*0367	*0377	*0392	0395			
M 923	0062	*0361	*0368	*0378	*0393	0397			
M 924	*0362	*0369	*0379	*0394	0399				
M 925	0403	*0422							
M 926	0406	*0424							
M 927	0409	*0426							
M 929	0048	0054	*0059						
M 930	*0252	0370	0386						
M 932	*0258	0371	0387						
M 933	*0264	0356							
M 934	*0278	0363							
M 935	*0276	0372							
M 936	*0282	0373							
M 938	*0288	0380							
M 939	*0294	0385							
M 943	*0300	0357	0381						
M 944	*0306	0364	0382						
M 945	*0315	0374	0388						
M 948	*0241	0247	0253	0259	0265	0271	0277	0283	
		0289							
M 949	*0246	0295	0301						
M 950	*0404	0411							
M 951	*0407	0412							
M 952	*0410	0413							
M 960	*0320	0453							
M 961	*0325	0456							
M 962	*0330	0459							
M 963	*0335	0462							
M 964	*0340	0465							
M 965	*0345	0468							
M 966	*0350	0471							
M 967	*0355	0474							
M 968	0562	*0568	*0583						
M 969	0570	*0576	*0586						
M 2000	0033								

Marker Nos. – Used with PLC-command-numbers

M 2001	0035							
M 2002	0037							
M 2003	0039							
M 2008	0077	0115	0127					
M 2009	0081	0118	0130					
M 2010	0085	0121	0133					
M 2011	0089	0124	0136					
M 2032	0525							
M 2033	0528							
M 2034	0531							
M 2035	0534							
M 2036	0537							
M 2037	0540							
M 2038	0543							
M 2039	0546							
M 2043	0316	0321	0326	0331	0336	0341	0346	0351
	0401	0420	0437	0445	0452	0455	0458	0461
	0464	0467	0470	0473	0548	0561	0569	0587
M 2044	0402	0421	0439	0446	0476	0479	0482	0485
	0488	0491	0494	0497	0549	0592		
M 2045	0358	0365	0375	0383	0389	0405	0423	0441
	0447	0500	0503	0506	0509	0512	0515	0518
	0521	0553	0597					
M 2046	0408	0425	0443	0448	0524	0527	0530	0533
	0536	0539	0542	0545	0557	0602		
M 2064	0477							
M 2065	0480							
M 2066	0483							
M 2067	0486							
M 2068	0489							
M 2069	0492							
M 2070	0495							
M 2071	0498							
M 2072	0248	0254	0260	0266	0272	0278	0284	0290
	0296	0302	0307	0501				
M 2073	0249	0255	0261	0267	0273	0279	0285	0291
	0297	0303	0308	0504				
M 2074	0250	0256	0262	0268	0274	0280	0286	0292
	0298	0304	0309	0507				
M 2075	0251	0257	0263	0269	0275	0281	0287	0293
	0299	0305	0310	0510				
M 2076	0237	0242	0311	0513				
M 2077	0238	0243	0312	0516				
M 2078	0239	0244	0313	0519				
M 2079	0240	0245	0314	0522				
M 2104	0317	0322	0327	0332	0337	0342	0347	0352
M 2105	0318	0323	0328	0333	0338	0343	0348	0353
M 2106	0319	0324	0329	0334	0339	0344	0349	0354
M 2176	0001	0005	0009	0013	0017	0021		
M 2177	0002	0006	0010	0014	0018	0022		
M 2178	0003	0007	0011	0015	0019	0023		
M 2184	0041	0060						
M 2185	0046	0052						
M 2191	0391							
M 2448	*0157	*0183						
M 2449	*0158	*0187						
M 2450	*0159	*0191						

Marker Nos. — Used with PLC-command-numbers

M 2451	*0138	*0139	*0145
M 2456	*0160	*0200	
M 2457	*0161	*0205	
M 2458	*0162	*0210	
M 2459	*0163	*0215	
M 2460	*0164	*0220	
M 2461	*0165	*0225	
M 2462	*0166	*0230	
M 2463	*0167	*0235	
M 2464	*0168	*0184	
M 2465	*0169	*0188	
M 2466	*0170	*0192	
M 2467	*0140	*0141	*0146
M 2472	*0171	*0201	
M 2473	*0172	*0206	
M 2474	*0173	*0211	
M 2475	*0174	*0216	
M 2476	*0175	*0221	
M 2477	*0176	*0226	
M 2478	*0177	*0231	
M 2479	*0178	*0236	
M 2480	*0438	*0591	
M 2481	*0440	*0596	
M 2482	*0442	*0601	
M 2483	*0444	*0606	
M 2485	*0396		
M 2486	*0398		
M 2487	*0400		
M 2488	*0180		
M 2490	*0578		
M 2491	*0580		
M 2492	*0072		
M 2493	*0073		
M 2494	*0074		
M 2495	*0075		
M 2544	*0078	0094	0114 *0128
M 2545	*0082	0099	0117 *0131
M 2546	*0086	0104	0120 *0134
M 2547	*0090	0109	0123 *0137
M 2552	*0095		
M 2553	*0100		
M 2554	*0105		
M 2555	*0110		
M 2556	*0148		
M 2557	*0150		
M 2558	*0152		
M 2559	*0154		
M 2815	*0050	*0056	

Input Nos. — Used with PLC-command-numbers

E 0	0147			
E 1	0149			
E 2	0151			
E 3	0153			
E 8	0045	0051	0058	
E 9	0198	0204		
E 10	0199	0203		
E 11	0208	0214		
E 12	0209	0213		
E 13	0218	0224		
E 14	0219	0223		
E 15	0228	0234		
E 16	0229	0233		
E 17	0590	0595	0600	0605
E 18	0144			
E 19	0066	0069		
E 20	0049	0055		
E 21	0185	0195		
E 22	0181	0190	0193	
E 23	0179			

Output Nos. — Used with PLC-command-numbers

A 0	*0034				
A 1	*0036				
A 2	*0038				
A 3	*0040				
A 4	*0042				
A 5	*0044				
A 6	0047	0053	0057	*0065	
A 7	*0429	*0454	*0478	*0502	*0526
A 8	*0430	*0457	*0481	*0505	*0529
A 9	*0431	*0460	*0484	*0508	*0532
A 10	*0432	*0463	*0487	*0511	*0535
A 11	*0433	*0466	*0490	*0514	*0538
A 12	*0434	*0469	*0493	*0517	*0541
A 13	*0435	*0472	*0496	*0520	*0544
A 14	*0436	*0475	*0499	*0523	*0547
A 15	*0359				
A 16	*0366				
A 17	*0376				
A 18	*0384				
A 19	*0390				
A 20	*0552				
A 21	*0556				
A 22	*0560				

Timer Nos. — Used with PLC-command-numbers

T 10	*0417					
T 11	*0418					
T 12	*0419	0588	0593	0598	0603	
T 13	0563	*0567	0571	0581		
T 14	0564	0572	*0575	0584		
T 15	*0112	*0113	*0116	*0119	*0122	*0125 0142
T 58	0414	*0449	0550	0554	0558	
T 59	0415	*0450	0551	0555	0559	
T 60	0416	*0451	0589	0594	0599	0604
T 61	0565	0573	0577	0582		
T 62	0566	0574	0579	0585		
T 63	0143					

D 3) Standard PLC-program

0000 =	M 0	Choses a logic chain where it is incomplete at the end of the program
		Mode decoding
0001 UN	M 2176	Mode-code 2 ⁰
0002 UN	M 2177	Mode-code 2 ¹
0003 UN	M 2178	Mode-code 2 ²
0004 =	M 900	"Store program" mode
0005 U	M 2176	Mode-code 2 ⁰
0006 UN	M 2177	Mode-code 2 ¹
0007 UN	M 2178	Mode-code 2 ²
0008 =	M 901	"Manual" mode
0009 UN	M 2176	Mode-code 2 ⁰
0010 U	M 2177	Mode-code 2 ¹
0011 UN	M 2178	Mode-code 2 ²
0012 =	M 902	"Electronic handwheel" mode
0013 U	M 2176	Mode-code 2 ⁰
0014 U	M 2177	Mode-code 2 ¹
0015 UN	M 2178	Mode-code 2 ²
0016 =	M 903	"Manual data input" mode
0017 UN	M 2176	Mode-code 2 ⁰
0018 UN	M 2177	Mode-code 2 ¹
0019 U	M 2178	Mode-code 2 ²
0020 =	M 904	"Single block" mode
0021 U	M 2176	Mode-code 2 ⁰
0022 UN	M 2177	Mode-code 2 ¹
0023 U	M 2178	Mode-code 2 ²
0024 =	M 905	"Automatic" mode
0025 O	M 900	"Store program" mode
0026 O	M 901	"Manual" mode
0027 O	M 902	"Electronic handwheel" mode
0028 =	M 908	Manual modes
0029 O	M 903	"Manual data input" mode
0030 O	M 904	"Single block" mode
0031 O	M 905	"Automatic" mode
0032 =	M 909	Control in "automatic" mode
		Axis enables
0033 U	M 2000	Enable X-axis
0034 =	A 0	Terminal J1/1
0035 U	M 2001	Enable Y-axis
0036 =	A 1	Terminal J1/2
0037 U	M 2002	Enable Z-axis
0038 =	A 2	Terminal J1/3
0039 U	M 2003	Enable IV-axis
0040 =	A 3	Terminal J1/4

0041	U	M 2184	Control in operation
0042	=	A 4	Terminal J1/5
0043	U	M 909	Control in automatic mode
0044	=	A 5	Terminal J1/6
			Checking for spindle on
0045	U	E8	Feedback, Emergency stop test
0046	U	M 2185	1st. PLC-cycle following PLC cycle interruption
0047	U	A 6	Check for "spindle on": Terminal J1/7
0048	U	M 929	Buffer marker A6 – delayed during 1st PLC cycle (contact opened)
0049	UN	E 20	Spindle checking feedback terminal J5/4
0050	S	M 2815	Flashing alarm from PLC
0051	U	E 8	Feedback, Emergency stop test
0052	U	M 2185	1st PLC-cycle following PLC cycle interruption
0053	UN	A 6	Check for "spindle on" terminal J1/7
0054	UN	M 929	Buffer marker A6 – delayed during 1st PLC-cycle (contact opened)
0055	U	E 20	Spindle checking feedback: Terminal J5/4
0056	S	M 2815	Flashing alarm from PLC
0057	U	A 6	Check for "spindle on": Terminal J1/7
0058	U	E 8	Feedback, Emergency stop test
0059	=	M 929	Buffer marker A6 – delayed during 1st PLC-cycle (contact opened)
			Checking for "Spindle on"
0060	O	M 2184	Control in operation
0061	O	M 922	Buffer marker M03
0062	O	M 923	Buffer marker M04
0063	U	M 909	Control in "automatic" mode
0064	O	M 908	Manual mode
0065	=	A 6	Check for "spindle on": Terminal J1/7
			Manual pressed – Disable servo-loops
			Following manual presse, transfer position value
0066	U	E 19	Input manual pressed: Terminal J5/5
0067	U	M 917	Buffer marker – E19 delayed during 1st PLC cycle (contact opened)
0068	=	M 919	Manual pressed
0069	U	E 19	Input Manual pressed
0070	=	M 917	Buffer marker – E19 delayed during 1st PLC-cycle (contact opened)
			Pre-select servo-enable
0071	U	M 919	Manual pressed
0072	=	M 2492	Initial marker: X-servo-loop enabled
0073	=	M 2493	Initial marker: Y-servo-loop enabled
0074	=	M 2494	Initial marker: Z-servo-loop enabled
0075	=	M 2495	Initial marker: V-servo-loop enabled

Switch "Manual pressed" disables servo-loop if axes are in position

0076	U	M 919	Manual pressed
0077	U	M 2008	X-axis in position
0078	S	M 2544	Disable X-axis servo-loop
0079	S	M 910	Buffer marker X-axis actual position value transfer
0080	U	M 919	Manual pressed
0081	U	M 2009	Y-axis in position
0082	S	M 2545	Disable Y-axis servo-loop
0083	S	M 911	Buffer marker Y-axis actual position value transfer
0084	U	M 919	Manual pressed
0085	U	M 2010	Z-axis in position
0086	S	M 2546	Disable Z-axis servo-loop
0087	S	M 912	Buffer marker Z-axis actual position value transfer
0088	U	M 919	Manual pressed
0089	U	M 2011	IV-axis in position
0090	S	M 2547	Disable IV-axis servo-loop
0091	S	M 913	Buffer marker IV-axis
			Position value transfer
0092	U	M 910	Buffer marker X-axis actual position value transfer
0093	UN	M 919	Manual pressed
0094	U	M 2544	Disable X-axis servo-loop
0095	=	M 2552	Transfer X-axis position value
0096	R	M 910	Buffer marker X-axis actual position value transfer
0097	U	M 911	Buffer marker Y-axis actual position value transfer
0098	UN	M 919	Manual pressed
0099	U	M 2545	Disable Y-axis servo-loop
0100	=	M 2553	Transfer Y-axis position value
0101	R	M 911	Buffer marker Y-axis actual position value transfer
0102	U	M 912	Buffer marker Z-axis actual position value transfer
0103	UN	M 919	Manual pressed
0104	U	M 2546	Disable Z-axis servo-loop
0105	=	M 2554	Transfer Z-axis position value
0106	R	M 912	Buffer marker Z-axis actual position value transfer
0107	U	M 913	Buffer marker IV-axis
0108	UN	M 919	Manual pressed
0109	U	M 2547	Disable IV-axis servo-loop
0110	=	M 2555	Transfer IV-axis actual position value
0111	R	M 913	Buffer marker IV-axis

Time for Delaying Feed Enable Start

0112	R	T 15	Delay feed enable
0113	RN	T 15	
0114	U	M 2544	Disable X-axis servo-loop
0115	UN	M 2008	X-axis in position
0116	S	T 15	Delay feed enable
0117	U	M 2545	Disable Y-axis servo-loop
0118	UN	M 2009	Y-axis in position
0119	S	T 15	Delay feed enable
0120	U	M 2546	Disable Z-axis servo-loop
0121	UN	M 2010	Z-axis in position
0122	S	T 15	Delay feed enable
0123	U	M 2547	Disable IV-axis servo-loop
0124	UN	M 2011	IV-axis in position
0125	S	T 15	Delay feed enable
Enable Servo-loop if axis is not in position or manual not activated			
0126	ON	M 919	Manual pressed
0127	ON	M 2008	X-axis in position
0128	R	M 2544	Enable X-axis servo-loop (servo-loop X-axis inhibiting not permitted)
0129	ON	M 919	Manual pressed
0130	ON	M 2009	Y-axis in position
0131	R	M 2545	Enable Y-axis servo-loop (servo-loop Y-axis inhibiting not permitted)
0132	ON	M 919	Manual pressed
0133	ON	M 2010	Z-axis in position
0134	R	M 2546	Enable Z-axis servo-loop (servo-loop Z-axis inhibiting not permitted)
0135	ON	M 919	Manual pressed
0136	ON	M 2011	IV-axis in position
0137	R	M 2547	Enable IV-axis servo loop (servo-loop IV-axis inhibiting not permitted)
Feed enable			
0138	R	M 2451	Feed enable TNC
0139	RN	M 2451	
0140	S	M 2467	Complement TNC-feed enable
0141	SN	M 2467	
0142	UN	T 15	Delayed feed enable
0143	UN	T 63	Timer T15 running
0144	U	E 18	Feed enable
0145	S	M 2451	TNC feed enable
0146	R	M 2467	Complement feed enable
Reference Point Switch			
0147	U	E 0	Terminal J5/9
0148	=	M 2556	X-axis REF end position
0149	U	E 1	Terminal J5/10
0150	=	M 2557	Y-axis REF end position
0151	U	E 2	Terminal J5/11
0152	=	M 2558	Z-axis REF end position
0153	U	E 3	Terminal J5/12
0154	=	M 2559	IV-axis REF end position

Start conditions for setting button markers

0155	O	M 0	
0156	ON	M 0	
0157	R	M 2448	NC-Start
0158	R	M 2449	Rapid
0159	R	M 2450	Memory function for normal traverse
0160	R	M 2456	Manual traverse X+
0161	R	M 2457	Manual traverse X-
0162	R	M 2458	Manual traverse Y+
0163	R	M 2459	Manual traverse Y-
0164	R	M 2460	Manual traverse Z+
0165	R	M 2461	Manual traverse Z-
0166	R	M 2462	Manual traverse IV+
0167	R	M 2463	Manual traverse IV-
0168	S	M 2464	Complement of start
0169	S	M 2465	Complement of rapid
0170	S	M 2466	Complement memory function for manual traverse
0171	S	M 2472	Complement of manual traverse X+
0172	S	M 2473	Complement of manual traverse X-
0173	S	M 2474	Complement of manual traverse Y+
0174	S	M 2475	Complement of manual traverse Y-
0175	S	M 2476	Complement of manual traverse Z+
0176	S	M 2477	Complement of manual traverse Z-
0177	S	M 2478	Complement of manual traverse IV+
0178	S	M 2479	Complement of manual traverse IV--
Stop-, Start-, Rapid button, Memory function for manual traversing			
0179	U	E 23	NC-Stop button: Terminal J5/1
0180	=	M 2488	NC-Stop
0181	U	E 22	NC-Start-button: Terminal J5/2
0182	U	M 920	Buffered marker, start button delayed during 1st PLC cycle (contact is opened)
0183	S	M 2448	NC-Start
0184	R	M 2464	Complemented NC-Start
0185	U	E 21	Rapid button: Terminal J5/3
0186	U	M 921	Buffer marker: rapid button delayed during 1st PLC cycle (contact is opened)
0187	S	M 2449	Rapid
0188	R	M 2465	Complement of rapid
0189	U	M 908	Manual mode
0190	U	E 22	NC-Start button
0191	S	M 2450	Memory function for manual traverse
0192	R	M 2466	Complemented memory function for manual traverse
0193	U	E 22	NC-Start-button: Terminal J5/2
0194	=	M 920	Buffer marker: NC-Start button
0195	U	E 21	Rapid button: Terminal J5/3
0196	=	M 921	Buffer marker: rapid button

Direction buttons

0197	U	M 908	Manual mode
0198	U	E 9	X+ direction button: Terminal J6/5
0199	UN	E 10	X- direction button: Terminal J6/6
0200	S	M 2456	X+ direction button
0201	R	M 2472	X+ direction button complemented
0202	U	M 908	Manual mode
0203	U	E 10	X- direction button: Terminal J6/6
0204	UN	E 9	X+ direction button: Terminal J6/5
0205	S	M 2457	X- direction button
0206	R	M 2473	X- direction button complemented
0207	U	M 908	Manual mode
0208	U	E 11	Y+ direction button: Terminal J6/7
0209	UN	E 12	Y- direction button: Terminal J6/8
0210	S	M 2458	Y+ direction button
0211	R	M 2474	Y+ direction button complemented
0212	U	M 908	Manual mode
0213	U	E 12	Y- direction button: Terminal J6/8
0214	UN	E 11	Y+ direction button: Terminal J6/7
0215	S	M 2459	Y- direction button
0216	R	M 2475	Y- direction button complemented
0217	U	M 908	Manual mode
0218	U	E 13	Z+ direction button: Terminal J6/9
0219	UN	E 14	Z- direction button: Terminal J6/10
0220	S	M 2460	Z+ direction button
0221	R	M 2476	Z+ direction button complemented
0222	U	M 908	Manual mode
0223	U	E 14	Z- direction button: Terminal J6/10
0224	UN	E 13	Z+ direction button: Terminal J6/9
0225	S	M 2461	Z- direction button
0226	R	M 2477	Z- direction button complemented
0227	U	M 908	Manual mode
0228	U	E 15	IV+ direction button: Terminal J6/11
0229	UN	E 16	IV- direction button: Terminal J6/12
0230	S	M 2462	IV+ direction button
0231	R	M 2478	IV+ direction button complemented
0232	U	M 908	Manual mode
0233	U	E 16	IV- direction button: Terminal J6/12
0234	UN	E 15	IV+ direction button: Terminal J6/11
0235	S	M 2463	IV- direction button
0236	R	M 2479	IV- direction button complemented

Buffer markers for setting M-codes

0237	UN	M 2076	5th Bit M-code
0238	UN	M 2077	6th Bit M-code
0239	UN	M 2078	7th Bit M-code
0240	UN	M 2079	8th Bit M-code
0241	=	M 948	Buffer marker M-code decimal decade 0 x
0242	U	M 2076	5th Bit M-code
0243	UN	M 2077	6th Bit M-code
0244	UN	M 2078	7th Bit M-code
0245	UN	M 2079	8th Bit M-code
0246	=	M 949	Buffer marker M-code decimal decade 1 x
0247	U	M 948	Buffer marker M-code decimal decade 0 x
0248	UN	M 2072	1st Bit M-code
0249	UN	M 2073	2nd Bit M-code
0250	UN	M 2074	3rd Bit M-code
0251	UN	M 2075	4th Bit M-code
0252	=	M 930	Buffered marker M00
0253	U	M 948	Buffer marker M-code decimal decade 0 x
0254	UN	M 2072	1st Bit M-code
0255	U	M 2073	2nd Bit M-code
0256	UN	M 2074	3rd Bit M-code
0257	UN	M 2075	4th Bit M-code
0258	=	M 932	Buffered marker M02
0259	U	M 948	Buffer marker M-code decimal decade 0 x
0260	U	M 2072	1st Bit M-code
0261	U	M 2073	2nd Bit M-code
0262	UN	M 2074	3rd Bit M-code
0263	UN	M 2075	4th Bit M-code
0264	=	M 933	Buffered marker M03
0265	U	M 948	Buffer marker M-code decimal decade 0 x
0266	UN	M 2072	1st Bit M-code
0267	UN	M 2073	2nd Bit M-code
0268	U	M 2074	3rd Bit M-code
0269	UN	M 2075	4th Bit M-code
0270	=	M 934	Buffered marker M04
0271	U	M 948	Buffer marker M-code decimal decade 0 x
0272	U	M 2072	1st Bit M-code
0273	UN	M 2073	2nd Bit M-code
0274	U	M 2074	3rd Bit M-code
0275	UN	M 2075	4th Bit M-code
0276	=	M 935	Buffered marker M05
0277	U	M 948	Buffer marker M-code decimal decade 0 x
0278	UN	M 2072	1st Bit M-code
0279	U	M 2073	2nd Bit M-code
0280	U	M 2074	3rd Bit M-code
0281	UN	M 2075	4th Bit M-code
0282	=	M 936	Buffered marker M06
0283	U	M 948	Buffer marker M-code decimal decade 0 x
0284	UN	M 2072	1st Bit M-code
0285	UN	M 2073	2nd Bit M-code
0286	UN	M 2074	3rd Bit M-code
0287	U	M 2075	4th Bit M-code
0288	=	M 938	Buffered marker M08

0289	U	M 948	Buffer marker M-code decimal decade 0 x
0290	U	M 2072	1st Bit M-code
0291	UN	M 2073	2nd Bit M-code
0292	UN	M 2074	3rd Bit M-code
0293	U	M 2075	4th Bit M-code
0294	=	M 939	Buffered marker M09
0295	U	M 949	Buffer marker M-code decimal decade 1 x
0296	U	M 2072	1st Bit M-code
0297	U	M 2073	2nd Bit M-code
0298	UN	M 2074	3rd Bit M-code
0299	UN	M 2075	4th Bit M-code
0300	=	M 943	Buffered marker M13
0301	U	M 949	Buffer marker M-code decimal decade 1 x
0302	UN	M 2072	1st Bit M-code
0303	UN	M 2073	2nd Bit M-code
0304	U	M 2074	3rd Bit M-code
0305	UN	M 2075	4th Bit M-code
0306	=	M 944	Buffered marker M14
0307	UN	M 2072	1st Bit M-code
0308	UN	M 2073	2nd Bit M-code
0309	UN	M 2074	3rd Bit M-code
0310	UN	M 2075	4th Bit M-code
0311	U	M 2076	5th Bit M-code
0312	U	M 2077	6th Bit M-code
0313	UN	M 2078	7th Bit M-code
0314	UN	M 2079	8th Bit M-code
0315	=	M 945	Buffered marker M30
Buffered markers for setting gear range codes			
0316	U	M 2043	Change gear signal
0317	UN	M 2104	1st Bit, gear range code (lsb)
0318	UN	M 2105	2nd Bit, gear range code
0319	UN	M 2106	3rd Bit, gear range code (msb)
0320	=	M 960	Gear range (0)
0321	U	M 2043	Change gear signal
0322	U	M 2104	1st Bit, gear range code (lsb)
0323	UN	M 2105	2nd Bit, gear range code
0324	UN	M 2106	3rd Bit, gear range code (msb)
0325	=	M 961	Gear range (1)
0326	U	M 2043	Change gear signal
0327	UN	M 2104	1st Bit, gear range code (lsb)
0328	U	M 2105	2nd Bit, gear range code
0329	UN	M 2106	3rd Bit, gear range code (msb)
0330	=	M 962	Gear range (2)
0331	U	M 2043	Change gear signal
0332	U	M 2104	1st Bit, gear range code (lsb)
0333	U	M 2105	2nd Bit, gear range code
0334	UN	M 2106	3rd Bit, gear range code (msb)
0335	=	M 963	Gear range (3)
0336	U	M 2043	Change gear signal
0337	UN	M 2104	1st Bit, gear range code (lsb)
0338	UN	M 2105	2nd Bit, gear range code
0339	U	M 2106	3rd Bit, gear range code (msb)
0340	=	M 964	Gear range (4)

0341	U	M 2043	Change gear signal
0342	U	M 2104	1st Bit, gear range code (lsb)
0343	UN	M 2105	2nd Bit, gear range code
0344	U	M 2106	3rd Bit, gear range code (msb)
0345	=	M 965	Gear range (5)
0346	U	M 2043	Change gear signal
0347	UN	M 2104	1st Bit, gear range code (lsb)
0348	U	M 2105	2nd Bit, gear range code
0349	U	M 2106	3rd Bit, gear range code (msb)
0350	=	M 966	Gear range (6)
0351	U	M 2043	Change gear signal
0352	U	M 2104	1st Bit, gear range code (lsb)
0353	U	M 2105	2nd Bit, gear range code
0354	U	M 2106	3rd Bit, gear range code (msb)
0355	=	M 967	Gear range (7)
Decoded M Output			
0356	O	M 933	Buffered marker M03
0357	O	M 943	Buffered marker M13
0358	U	M 2045	Change M
0359	=	A 15	M03 output/spindle CW: Terminal J2/10
0360	S	M 922	Buffered marker output M03
0361	R	M 923	Buffered marker output M04
0362	R	M 924	Buffered marker output M05
0363	O	M 934	Buffered marker M04
0364	O	M 944	Buffered marker M14
0365	U	M 2045	Change signal M
0366	=	A 16	M04 output/spindle CCW: Terminal J2/11
0367	R	M 922	Buffered marker output M03
0368	S	M 923	Buffered marker output M04
0369	R	M 924	Buffered marker output M05
0370	O	M 930	Buffered marker M00
0371	O	M 932	Buffered marker M02
0372	O	M 935	Buffered marker M05
0373	O	M 936	Buffered marker M06
0374	O	M 945	Buffered marker M30
0375	U	M 2045	Change signal M
0376	=	A 17	M05 output/spindle stop: Terminal J2/12
0377	R	M 922	Buffered marker output M03
0378	R	M 923	Buffered marker output M04
0379	S	M 924	Buffered marker output M05
0380	O	M 938	Buffered marker M08
0381	O	M 943	Buffered marker M13
0382	O	M 944	Buffered marker M14
0383	U	M 2045	Change signal M
0384	=	A 18	M08 output/coolant ON: Terminal J3/1
0385	O	M 939	Buffered marker M09
0386	O	M 930	Buffered marker M00
0387	O	M 932	Buffered marker M02
0388	O	M 945	Buffered marker M30
0389	U	M 2045	Change signal M
0390	=	A 19	M09 output/coolant OFF: Terminal J3/2

Emergency stop condition for spindle on/off

0391 U M 2191 Error message external emergency stop is displayed
0392 R M 922 Buffered marker output M03
0393 R M 923 Buffered marker output M04
0394 S M 924 Buffered marker output M05

Spindle status feedback to TNC

0395 U M 922 Buffered marker M03
0396 = M 2485 Status display M03

0397 U M 923 Buffered marker M04
0398 = M 2486 Status display M04

0399 U M 924 Buffered marker M05
0400 = M 2487 Status display M05

Setting timers for G-M-S-T1-output on leading edge

0401 O M 2043 G-change signal
0402 O M 2044 S-change signal
0403 UN M 925 1st buffered G/S change signal
0404 = M 950 2nd buffered G/S change signal

0405 U M 2045 M-change signal
0406 UN M 926 1st buffered M change signal
0407 = M 951 2nd buffered M change signal

0408 U M 2046 T1-change signal
0409 UN M 927 1st buffered T1-change signal
0410 = M 952 2nd buffered T1-change signal

0411 O M 950 2nd buffered G/S-change signal
0412 O M 951 2nd buffered M change signal
0413 O M 952 2nd buffered T1-change signal
0414 UN T 58 Timer 10 running
0415 UN T 59 Timer 11 running
0416 UN T 60 Timer 12 running
0417 = T 10 Start T10 (G-M-S-T delayed coded strobe output)
0418 = T 11 Start T11 (G-M-S-T output permanent strobe)
0419 = T 12 Start T12 (G-M-S-T delayed feedback output)

Setting buffered markers

0420 O M 2043 Change signal G
0421 O M 2044 Change signal S
0422 = M 925 1st buffered G/S-change signal

0423 U M 2045 Change signal M
0424 = M 926 1st buffered M-change signal

0425 U M 2046 Change signal T1
0426 = M 927 1st buffered T1-change signal

Resetting M-S-T-outputs

0427 O M 0
0428 ON M 0
0429 R A 7 Reset M-S-T-output Bit 1
0430 R A 8 Reset M-S-T-output Bit 2
0431 R A 9 Reset M-S-T-output Bit 3
0432 R A 10 Reset M-S-T-output Bit 4
0433 R A 11 Reset M-S-T-output Bit 5
0434 R A 12 Reset M-S-T-output Bit 6
0435 R A 13 Reset M-S-T-output Bit 7
0436 R A 14 Reset M-S-T-output Bit 8

Resetting the G-M-S-T completed" feedback signals

0437	U	M 2043	G-code change signal
0438	RN	M 2480	G-code feedback
0439	U	M 2044	S-code change signal
0440	RN	M 2481	S-code feedback
0441	U	M 2045	M-code change signal
0442	RN	M 2482	M-code feedback
0443	U	M 2046	T1-code change signal
0444	RN	M 2483	T1-code feedback
Timer for G-M-S-T-output reset			
0445	UN	M 2043	G-code change signal for S-analogue
0446	UN	M 2044	S-code change signal
0447	UN	M 2045	M-code change signal
0448	UN	M 2046	T-code change signal
0449	R	T 58	Timer 10 runs: Delay of strobe
0450	R	T 59	Timer 11 runs: Strobe duration
0451	R	T 60	Timer 12 runs: Delay of feedback signal "auxiliary function completed"
Gear range code output			
0452	U	M 2043	Gear change signal
0453	U	M 960	Gear range code (0)
0454	S	A 7	Gear range code Bit 1: Terminal J2/2
0455	U	M 2043	Gear change signal
0456	U	M 961	Gear change code (1)
0457	S	A 8	Gear range code Bit 2: Terminal J2/3
0458	U	M 2043	Gear change signal
0459	U	M 962	Gear range code (2)
0460	S	A 9	Gear range code Bit 3: Terminal J2/4
0461	U	M 2043	Gear change signal
0462	U	M 963	Gear range code (3)
0463	S	A 10	Gear range code Bit 4: Terminal J2/5
0464	U	M 2043	Gear change signal
0465	U	M 964	Gear range code (4)
0466	S	A 11	Gear range code Bit 5: Terminal J2/6
0467	U	M 2043	Gear change signal
0468	U	M 965	Gear range code (5)
0469	S	A 12	Gear range code Bit 6: Terminal J2/7
0470	U	M 2043	Gear change signal
0471	U	M 966	Gear range code (6)
0472	S	A 13	Gear range code Bit 7: Terminal J2/8
0473	U	M 2043	Gear change signal
0474	U	M 967	Gear range code (7)
0475	S	A 14	Gear range code Bit 8: Terminal J2/9
S-outputs			
0476	U	M 2044	Change S-signal
0477	U	M 2064	S-code Bit 1
0478	S	A 7	S-code Bit 1: Terminal J2/2
0479	U	M 2044	Change S-signal
0480	U	M 2065	S-code Bit 2
0481	S	A 8	S-code Bit 2: Terminal J2/3

0482	U	M 2044	Change S-signal
0483	U	M 2066	S-code Bit 3
0484	S	A 9	S-code Bit 3: Terminal J2/4
0485	U	M 2044	Change S-signal
0486	U	M 2067	S-code Bit 4
0487	S	A 10	S-code Bit 4: Terminal J2/5
0488	U	M 2044	Change S-signal
0489	U	M 2068	S-code Bit 5
0490	S	A 11	S-code Bit 5: Terminal J2/6
0491	U	M 2044	Change S-signal
0492	U	M 2069	S-code Bit 6
0493	S	A 12	S-code Bit 6: Terminal J2/7
0494	U	M 2044	Change S-signal
0495	U	M 2070	S-code Bit 7
0496	S	A 13	S-code Bit 7: Terminal J2/8
0497	U	M 2044	Change S-signal
0498	U	M 2071	S-code Bit 8
0499	S	A 14	S-code Bit 8: Terminal J2/9
			M-Code outputs
0500	U	M 2045	Change M-signal
0501	U	M 2072	M-code Bit 1
0502	S	A 7	M-code Bit 1: Terminal J2/2
0503	U	M 2045	Change M-signal
0504	U	M 2073	M-code Bit 2
0505	S	A 8	M-code Bit 2: Terminal J2/3
0506	U	M 2045	Change M-signal
0507	U	M 2074	M-code Bit 3
0508	S	A 9	M-code Bit 3: Terminal J2/4
0509	U	M 2045	Change M-signal
0510	U	M 2075	M-code Bit 4
0511	S	A 10	M-code Bit 4: Terminal J2/5
0512	U	M 2045	Change M-signal
0513	U	M 2076	M-code Bit 5
0514	S	A 11	M-code Bit 5: Terminal J2/6
0515	U	M 2045	Change M-signal
0516	U	M 2077	M-code Bit 6
0517	S	A 12	M-code Bit 6: Terminal J2/7
0518	U	M 2045	Change M-signal
0519	U	M 2078	M-code Bit 7
0520	S	A 13	M-code Bit 7: Terminal J2/8
0521	U	M 2045	Change M-signal
0522	U	M 2079	M-code Bit 8
0523	S	A 14	M-code Bit 8: Terminal J2/9

T-Code outputs

0524	U	M 2046	Change T1-signal
0525	U	M 2032	T-code Bit 1
0526	S	A 7	T-code Bit 1: Terminal J2/2
0527	U	M 2046	Change T1-signal
0528	U	M 2033	T-code Bit 2
0529	S	A 8	T-code Bit 2: Terminal J2/3
0530	U	M 2046	Change T1-signal
0531	U	M 2034	T-code Bit 3
0532	S	A 9	T-code Bit 3: Terminal J2/4
0533	U	M 2046	Change T1-signal
0534	U	M 2035	T-code Bit 4
0535	S	A 10	T-code Bit 4: Terminal J2/5
0536	U	M 2046	Change T1-signal
0537	U	M 2036	T-code Bit 5
0538	S	A 11	T-code Bit 5: Terminal J2/6
0539	U	M 2046	Change T1-signal
0540	U	M 2037	T-code Bit 6
0541	S	A 12	T-code Bit 6: Terminal J2/7
0542	U	M 2046	Change T1-signal
0543	U	M 2038	T-code Bit 7
0544	S	A 13	T-code Bit 7: Terminal J2/8
0545	U	M 2046	Change T1-signal
0546	U	M 2039	T-code Bit 8
0547	S	A 14	T-code Bit 8: Terminal J2/9
Gear M-S-T1-Strobe			
0548	O	M 2043	Change gear range signal
0549	O	M 2044	Change S-signal
0550	UN	T 58	Timer 10 running (G-M-S-T delayed coded strobe output)
0551	U	T 59	Timer 11 running (G-M-S-T output permanent strobe)
0552	=	A 20	Gear range strobe/S-strobe: Terminal J3/3
0553	U	M 2045	Change M-signal
0554	UN	T 58	Timer 10 running (G-M-S-T delayed coded strobe output)
0555	U	T 59	Timer 11 running (G-M-S-T output permanent strobe)
0556	=	A 21	M-strobe: Terminal J3/4
0557	U	M 2046	Change T1-signal
0558	UN	T 58	Timer 10 running (G-M-S-T delayed coded strobe output)
0559	U	T 59	Timer 11 running (G-M-S-T output permanent strobe)
0560	=	A 22	T1-strobe: Terminal J3/5

Spindle jog when gear changing

0561	U	M 2043	Change gear signal
0562	UN	M 968	Buffer marker T13 running
0563	UN	T 13	Jog duration, spindle cw
0564	UN	T 14	Jog duration, spindle ccw
0565	UN	T 61	Timer 13 running (jog duration, spindle cw)
0566	UN	T 62	Timer 14 running (jog duration, spindle ccw)
0567	=	T 13	Start timer 13 (jog duration, spindle cw)
0568	S	M 968	Buffer marker T13 running
0569	U	M 2043	Change gear signal
0570	UN	M 969	Buffer marker T14 running
0571	UN	T 13	Jog duration, spindle cw
0572	UN	T 14	Jog duration, spindle ccw
0573	UN	T 61	Timer 13 running (jog spindle cw)
0574	UN	T 62	Timer 14 running (jog spindle ccw)
0575	=	T 14	Timer 14 start (jog spindle ccw)
0576	S	M 969	Buffer marker T14 running
0577	U	T 61	Timer 13 running (jog spindle cw)
0578	=	M 2490	Jog cw (to start spindle)
0579	U	T 62	Timer 14 running (jog spindle ccw)
0580	=	M 2491	Jog ccw (to start spindle)
Resetting buffer markers			
0581	UN	T 13	Jog duration spindle cw
0582	UN	T 61	Timer 13 running
0583	R	M 968	Buffer marker T13 running
0584	UN	T 14	Jog duration spindle ccw
0585	UN	T 62	Timer 14 running
0586	R	M 969	Buffer marker T14 running
M-S-T1-Code feedback when T12: timed out			
0587	U	M 2043	Change gear signal
0588	UN	T 12	G-M-S-T output: delay feedback
0589	UN	T 60	Timer 12 running
0590	U	E 17	Auxiliary function complete feedback: Terminal J5/7
0591	S	M 2480	Gear range feedback
0592	U	M 2044	Change S-signal
0593	UN	T 12	G-M-S-T output: delay feedback
0594	UN	T 60	Timer 12 running
0595	U	E 17	Auxiliary function complete feedback: Terminal J5/7
0596	S	M 2481	S feedback
0597	U	M 2045	Change M-signal
0598	UN	T 12	G-M-S-T output: delay feedback
0599	UN	T 60	Timer 12 running
0600	U	E 17	Auxiliary function complete feedback: Terminal J5/7
0601	S	M 2482	M feedback
0602	U	M 2046	Change T1-signal
0603	UN	T 12	G-M-S-T output: delay feedback
0604	UN	T 60	Timer 12 running
0605	U	E 17	Auxiliary function complete feedback: Terminal J5/7
0606	S	M 2483	T1 feedback

D 4) New functions as of PLC-Software number 234 60103:

The following functions can be called via machine parameter 158:

- .release of probing function
- .actual value transfer after opening of the closed positioning loop
- .spindle orientation (Vth axis)

D 4.1) Actual value transfer after opening of the closed positioning loops

The input "manual traverse" (this opens the closed positioning loop) has two different function modes:

- .after opening of the closed positioning loops the actual position of the axes is transferred as nominal position or
- .after opening of the closed positioning loops the actual position of the axes is **not** transferred as nominal position.

If actual value transfer is required after opening of the closed positioning loops, simply add 16384 to the already existing entry value of machine parameter 158.

D 4.2) Spindle orientation (Vth axis)

If spindle orientation is to be possible with function M19, then 4096 must be added to the already existing entry value of machine parameter 158.

With command M19 the fifth axis positions to the position nominal value which has been determined in cycle "orientation". If cycle "orientation" has not been programmed, the position will be approached via machine parameter 240 (position value on the reference mark).

If 8192 is added to the existing entry value of machine parameter 158, then the position nominal value for the fifth axis is the contents of machine parameter 156 (position value for PLC positioning).

In order that the machine interface can recognize the duration of the spindle orientation, the M-strobe-Signal is logical "1" for the duration of spindle positioning. This means that feedback of the command M19 should only take place after the trailing edge of the M-Strobe-Signal (i. e. no feedback message for command M19 is accepted until the spindle position has been reached).

The spindle position is maintained after M19, until one of the following M-functions is output:
M00, M02, M03, M04, M05, M13, M14, M30.

D 4.3) Summary of the new functions as of PLC-Software-number 234 60103

	Release via machine parameter 158 The following is to be added:
Actual value transfer after opening of the closed positioning loop	16384
Spindle orientation	4096
Spindle position from machine parameter 156	8192

An activated function is inhibited again by subtracting the corresponding numerical values from the entry value of machine parameter 158.

D 5) Terminal layout for input/output signals for TNC

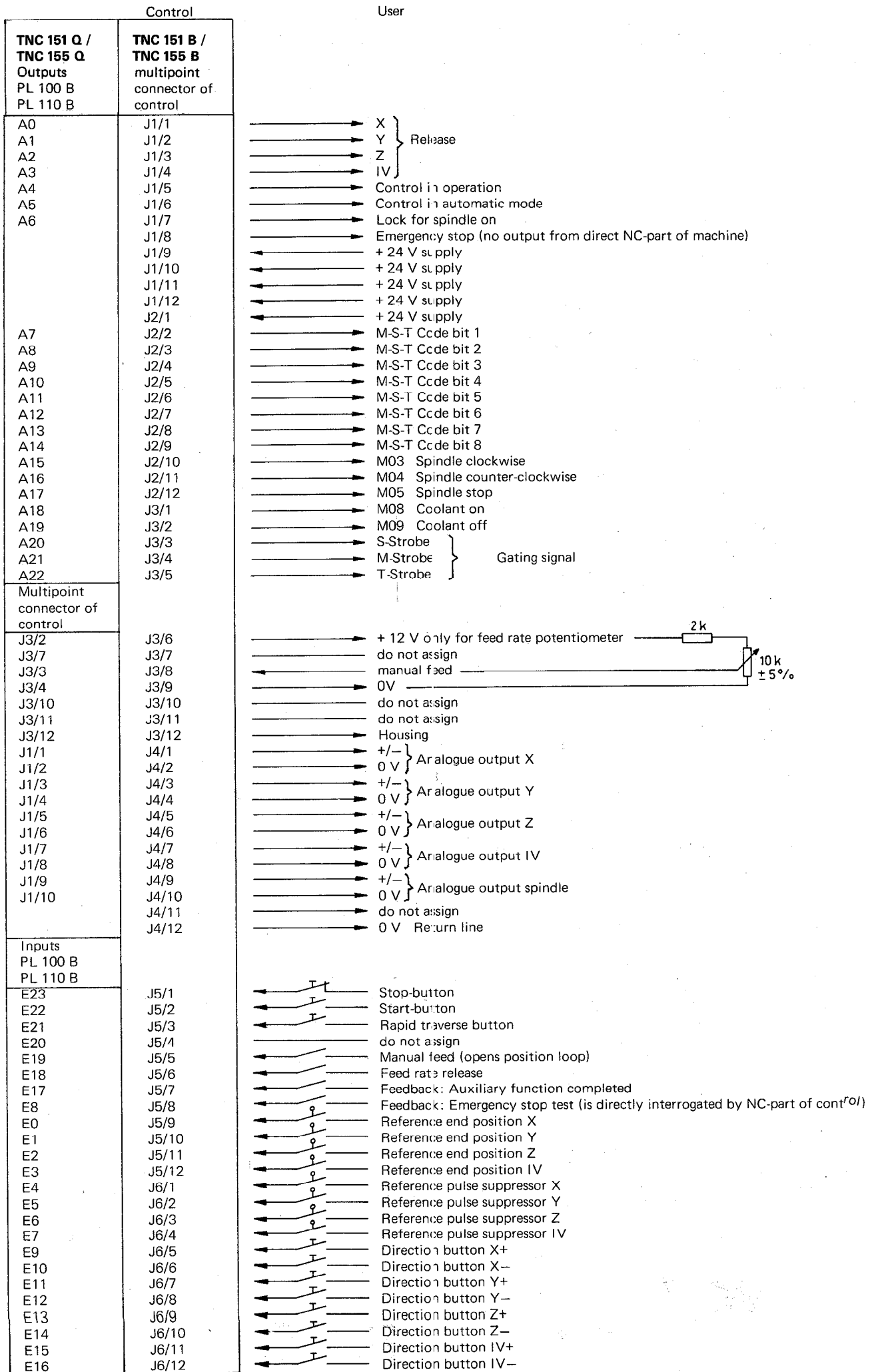

TNC 151 Q / TNC 155 Q connector J2/1 - J2/12 do not assign

E) Programming list

PLC-program list

Command No.	Command	Remarks
0		
1		
2		
3		
4		
5		
6		
7		
8		
9		
0		
1		
2		
3		
4		
5		
6		
7		
8		
9		
0		
1		
2		
3		
4		
5		
6		
7		
8		
9		
0		
1		
2		
3		
4		
5		
6		
7		
8		
9		
0		

PLC-program list

Command No.	Command	Remarks
0		
1		
2		
3		
4		
5		
6		
7		
8		
9		
0		
1		
2		
3		
4		
5		
6		
7		
8		
9		
0		
1		
2		
3		
4		
5		
6		
7		
8		
9		
0		
1		
2		
3		
4		
5		
6		
7		
8		
9		
0		

Inputs

First PCB

Input	Remarks
E 0	Reference end position X
E 1	Reference end position Y
E 2	Reference end position Z
E 3	Reference end position IV
E 4	Reference pulse inhibit X
E 5	Reference pulse inhibit Y
E 6	Reference pulse inhibit Z
E 7	Reference pulse inhibit IV
E 8	Feedback, Emergency stop
E 9	
E 10	
E 11	
E 12	
E 13	
E 14	
E 15	
E 16	
E 17	
E 18	
E 19	
E 20	
E 21	
E 22	
E 23	
E 24	
E 25	
E 26	
E 27	
E 28	
E 29	
E 30	
E 31	
E 32	
E 33	
E 34	
E 35	
E 36	
E 37	
E 38	

Input	Remarks
E 39	
E 40	
E 41	
E 42	
E 43	
E 44	
E 45	
E 46	
E 47	
E 48	
E 49	
E 50	
E 51	
E 52	
E 53	
E 54	
E 55	
E 56	
E 57	
E 58	
E 59	
E 60	
E 61	
E 62	
E 63	Overload of an output stage (internally wired)

Inputs

Second PCB

Input	Remarks
E 64	
E 65	
E 66	
E 67	
E 68	
E 69	
E 70	
E 71	
E 72	
E 73	
E 74	
E 75	
E 76	
E 77	
E 78	
E 79	
E 80	
E 81	
E 82	
E 83	
E 84	
E 85	
E 86	
E 87	
E 88	
E 89	
E 90	
E 91	
E 92	
E 93	
E 94	
E 95	
E 96	
E 97	
E 98	
E 99	
E 100	
E 101	
E 102	

Input	Remarks
E 103	
E 104	
E 105	
E 106	
E 107	
E 108	
E 109	
E 110	
E 111	
E 112	
E 113	
E 114	
E 115	
E 116	
E 117	
E 118	
E 119	
E 120	
E 121	
E 122	
E 123	
E 124	
E 125	
E 126	
E 127	Overload of an output stage (internally wired)

Outputs**First PCB**

Output	Remarks
A 0	
A 1	
A 2	
A 3	
A 4	
A 5	
A 6	
A 7	
A 8	
A 9	
A 10	
A 11	
A 12	
A 13	
A 14	
A 15	
A 16	
A 17	
A 18	
A 19	
A 20	
A 21	
A 22	
A 23	
A 24	
A 25	
A 26	
A 27	
A 28	
A 29	
A 30	
A 31	Cancellation of "overload condition" (internally wired)

Outputs**Second PCB**

Output	Remarks
A 32	
A 33	
A 34	
A 35	
A 36	
A 37	
A 38	
A 39	
A 40	
A 41	
A 42	
A 43	
A 44	
A 45	
A 46	
A 47	
A 48	
A 49	
A 50	
A 51	
A 52	
A 53	
A 54	
A 55	
A 56	
A 57	
A 58	
A 59	
A 60	
A 61	
A 62	
A 63	Cancellation of "overload condition" (internally wired)

Marker list

Marker No.	Remarks
0	
1	
2	
3	
4	
5	
6	
7	
8	
9	
0	
1	
2	
3	
4	
5	
6	
7	
8	
9	
0	
1	
2	
3	
4	
5	
6	
7	
8	
9	
0	
1	
2	
3	
4	
5	
6	
7	
8	
9	
0	

Marker No.	Remarks
0	
1	
2	
3	
4	
5	
6	
7	
8	
9	
0	
1	
2	
3	
4	
5	
6	
7	
8	
9	
0	
1	
2	
3	
4	
5	
6	
7	
8	
9	
0	

F) List of machine parameters

Machine parameters which affect the PLC have been marked.

Function		Parameter No.	Entry values	
Rapid traverse	X	0	180 ... 15 999 [mm/min] (Axis IV: Degrees/min. with axis designation A or B or C)	
	Y	1		
	Z	2		
	IV	3		
Manual feed	X	4		
	Y	5		
	Z	6		
	IV	7		
Speed when approaching reference points	X	8	80 ... 15 999 [mm/min] (Axis IV: Degrees/min. with axis designation A or B or C)	
	Y	9		
	Z	10		
	IV	11		
Signal evaluation	X	12	1 $\hat{=}$ 20-fold	2 $\hat{=}$ 10-fold
	Y	13	(max. traversing speed	(max. traversing speed
	Z	14	16 m/min)	12 m/min)
	IV	15		
Traversing direction when approaching reference marks	X	16	0 $\hat{=}$ Plus-direction	1 $\hat{=}$ Minus-direction
	Y	17	(with correct programming of parameters Nos. 20 to 27)	
	Z	18		
	IV	19		
Counting direction	X	20	0 or 1	
	Y	21		
	Z	22		
	IV	23		
Polarity of nominal value voltage	X	24	0 $\hat{=}$ positive with positive traversing direction	
	Y	25	1 $\hat{=}$ negative with positive traversing direction	
	Z	26		
	IV	27		
Integral factor	X	28	0 ... 65 535	
	Y	29		
	Z	30		
	IV	31		
Differential factor	X	32	0 ... 65.535 (Values from table on section 6.2.3.1)	
	Y	33		
	Z	34		
	IV	35		
Backlash compensation	X	36	- 1.000 ... + 1.000 [mm]	
	Y	37		
	Z	38		
	IV	39		
Correction factor for linear correction	X	40	- 1.000 ... + 1.000 [mm/m]	
	Y	41		
	Z	42		
	IV	43		
Software limit switch ranges	X+	44	- 30000.000 ... + 30000.000 [mm] Angular axis - 30000.000 ... + 30000.000 [°]	
	X-	45		
	Y+	46		
	Y-	47		
	Z+	48		
	Z-	49		
	IV+	50		
IV-	51			

Function	Parameter No.	Entry values																								
Analogue voltage with rapid traverse	52	+ 4.5 ... + 9 [V]																								
Approach speed	53	0.1 ... 10 [m/min]																								
Acceleration	54	0.001 ... 1.5 [m/s ²] As of software version 08: 0.001 ... 3.0 [m/s ²]																								
Circular acceleration	55	0.001 ... 1.5 [m/s ²]																								
Position supervision (erasable)	56	0.001 ... 30 [mm]																								
Position supervision (emergency stop)	57																									
Position window X, Y, Z	58	0.001 ... 0.05 [mm]																								
Axis sequence for reference point approach	59	<table border="0"> <tr> <td>0 ≙ X Y Z IV</td> <td>12 ≙ Z X Y IV</td> </tr> <tr> <td>1 ≙ X Y IV Z</td> <td>13 ≙ Z X IV Y</td> </tr> <tr> <td>2 ≙ X Z Y IV</td> <td>14 ≙ Z Y X IV</td> </tr> <tr> <td>3 ≙ X Z IV Y</td> <td>15 ≙ Z Y IV X</td> </tr> <tr> <td>4 ≙ X IV Y Z</td> <td>16 ≙ Z IV X Y</td> </tr> <tr> <td>5 ≙ X IV Z Y</td> <td>17 ≙ Z IV Y X</td> </tr> <tr> <td>6 ≙ Y X Z IV</td> <td>18 ≙ IV X Y Z</td> </tr> <tr> <td>7 ≙ Y X IV Z</td> <td>19 ≙ IV X Z Y</td> </tr> <tr> <td>8 ≙ Y Z X IV</td> <td>20 ≙ IV Y X Z</td> </tr> <tr> <td>9 ≙ Y Z IV X</td> <td>21 ≙ IV Y Z X</td> </tr> <tr> <td>10 ≙ Y IV X Z</td> <td>22 ≙ IV Z X Y</td> </tr> <tr> <td>11 ≙ Y IV Z X</td> <td>23 ≙ IV Z Y X</td> </tr> </table>	0 ≙ X Y Z IV	12 ≙ Z X Y IV	1 ≙ X Y IV Z	13 ≙ Z X IV Y	2 ≙ X Z Y IV	14 ≙ Z Y X IV	3 ≙ X Z IV Y	15 ≙ Z Y IV X	4 ≙ X IV Y Z	16 ≙ Z IV X Y	5 ≙ X IV Z Y	17 ≙ Z IV Y X	6 ≙ Y X Z IV	18 ≙ IV X Y Z	7 ≙ Y X IV Z	19 ≙ IV X Z Y	8 ≙ Y Z X IV	20 ≙ IV Y X Z	9 ≙ Y Z IV X	21 ≙ IV Y Z X	10 ≙ Y IV X Z	22 ≙ IV Z X Y	11 ≙ Y IV Z X	23 ≙ IV Z Y X
0 ≙ X Y Z IV	12 ≙ Z X Y IV																									
1 ≙ X Y IV Z	13 ≙ Z X IV Y																									
2 ≙ X Z Y IV	14 ≙ Z Y X IV																									
3 ≙ X Z IV Y	15 ≙ Z Y IV X																									
4 ≙ X IV Y Z	16 ≙ Z IV X Y																									
5 ≙ X IV Z Y	17 ≙ Z IV Y X																									
6 ≙ Y X Z IV	18 ≙ IV X Y Z																									
7 ≙ Y X IV Z	19 ≙ IV X Z Y																									
8 ≙ Y Z X IV	20 ≙ IV Y X Z																									
9 ≙ Y Z IV X	21 ≙ IV Y Z X																									
10 ≙ Y IV X Z	22 ≙ IV Z X Y																									
11 ≙ Y IV Z X	23 ≙ IV Z Y X																									
Speed pre-control	60	0 ≙ on 1 ≙ off																								
Output of tool numbers	61	0 ≙ No output 1 ≙ Output only when tool number changes 2 ≙ Output of tool number with every tool call 3 ≙ Output of tool store number (if MP 225 ≥ 1)																								
Output of spindle speed codes or as S-Analogue voltage	62	0 ≙ No output of spindle rpm 1 ≙ Coded output only when rpm changes 2 ≙ Coded output of all rpms 3 ≙ S-Analogue voltage output Gear switching signal only when gear ratio changes 4 ≙ S-Analogue voltage output, Output of all gear switching signals 5 ≙ S-Analogue voltage output without gear switching signal																								
rpm code limit	63	01991																								
Oscillation when accelerating	64	0.01 ... 0.999																								
Display resolution	65	0 ≙ 1 μm 1 ≙ 5 μm																								
External feed rate potentiometer	66	0 ≙ internal potentiometer for override and manual feed 1 ≙ external potentiometer for override and manual feed 2 ≙ internal potentiometer for override external potentiometer for manual feed																								
Dwell time, rotation change of spindle in tapping cycle	67	0 ... 65.535 [s]																								

Function	Parameter No.	Entry values
Memory function for direction buttons	68	0 ≙ off 1 ≙ on
Special procedure for reference point	69	0 ≙ off 1 ≙ on
Nominal value voltage for spindle drive when tapping	70	0 ... 9.999 [V]
Characters for program end and beginning	71	0 ... 65535
Selection for control of inhibited axes	72	0 ≙ none 1 ≙ X- 2 ≙ Y- 3 ≙ X-, Y- 4 ≙ Z- 5 ≙ X-, Z- 6 ≙ Y-, Z- 7 ≙ X-, Y-, Z- 8 ≙ IV- 9 ≙ X-, IV- 10 ≙ Y-, IV- 11 ≙ X-, Y-, IV- 12 ≙ Z-, IV- 13 ≙ X-, Z-, IV- 14 ≙ Y-, Z-, IV- 15 ≙ X-, Y-, Z-, IV- Axis inhibited " "
Pre-cutout time for tapping cycle	73	0 ... 65535 [s]
Override effective on pressing rapid button	74	0 - 7 entry values, see table in section 6.1.2
Override in 2 % stages or variable		
Reference signal evaluation for inhibited axes	75	0 ≙ inactive 1 ≙ active
Display and transducer supervision for inhibited axes	76	0 ≙ inactive 1 ≙ active As of Software version 02 If 2 is added to entry value 1: X-axis inactive If 4 is added to entry value 1: Y-axis inactive If 8 is added to entry value 1: Z-axis inactive If 16 is added to entry value 1: IV-axis inactive
PLC program from RAM or from EPROM	77	0 ≙ RAM 1 ≙ EPROM
RPM-range gear ratios	0	0 ... 99999.999
S-Analogue output	1	
	2	
	3	
	4	
	5	
	6	
	7	
S-Analogue voltage with S-Override at 100 %	78	0 ... 9 999 [V]
S-Analogue voltage with S-Override at max. output voltage	79	
Limitation of S-Override	80	0 ... 150 [%]
Maximum	81	
Minimum	82	
Axis designation for axis IV	83	
	84	
	85	
	86	
	87	
Axis designation for axis IV	90	0 ≙ A 1 ≙ B 2 ≙ C 3 ≙ U 4 ≙ V 5 ≙ W
Constant contouring speed on external corners	91	0 ... 179.999 angles in degrees

Function	Parameter No.	Entry values
Decimal character in program output via V.24 · Selection of first dialog language (German, French, Italian, Spanish, Swedish, Finnish or Dutch) or the second dialogue language (English) · As of Software version 02 · Control check of power on	92	0 ≙ Decimal comma, first dialogue language 1 ≙ Decimal point, first dialogue language 2 ≙ Decimal comma, second dialogue language 3 ≙ Decimal point, second dialogue language If 2 is added to the previous entry value: basic language English If 4 is added: no memory check If 8 is added: no check sum test (the check sum test during operation of control remains unaffected)
Overlapping factor with pocket milling	93	0.1 ... 1.414
PLC: Counter predetermined value for counter 0 – 15	94 to 109	0 ... 65535 (in units of 20 ms)
PLC: Timer duration for timer 0 – 15	110 to 125	0 ... 65535 (in units of 20 ms)
PLC: 30 position values for PLC-positioning	126 to 156	- 30000.000 ... + 30000.000 [mm]
Activation of next tool No. or following store number	157	0 ≙ No output of next tool number 1 ≙ Output only with change of tool number 2 ≙ Output of next tool No. with every tool call 3 ≙ Output of next tool store number, programmable with TOOL DEF (if MP 225 ≥ 1)
Setting of 16 markers to binary number	158	0 ... 65535
Automatic lubrication to programmed traversing distance in X Y Z IV	159 to 162	0 ... 65535 (in 65536-µm-units)
Feed rate for parameters Nos. 126 to 156 X Y Z IV	163 164 165 166	80 ... 15999 (mm/min)
Display of current feed rate before start in MANUAL OPERATION mode (same feed rate in all axes)	167	0 ≙ off 1 ≙ on
Ramp gradient for S-Analogue	168	0 ... 1.999 [V/ms]
Standstill supervision	169	0.001 ... 30 [mm]
Programming station	170	0 ≙ Control 1 ≙ Programming station: PLC active 2 ≙ Programming station: PLC inactive
Handwheel and touch probe system	171	0 ≙ HR 150 or HR 250 and TS 510 1 ≙ HE 310 and TS 510 2 ≙ HR 150 or HR 250 and TS 110 3 ≙ HE 310 and TS 110
Polarity S-Analogue voltage	172	0 ≙ M 03: positive voltage M 04: negative voltage 1 ≙ M 03: negative voltage M 04: positive voltage 2 ≙ M 03 and M 04: positive voltage 3 ≙ M 03 and M 04: negative voltage
Cancellation of status display with M 02, M 30 and program end	173	0 ≙ Status display not to be cancelled 1 ≙ Status display to be cancelled
Trailing error supervision in trailing operation		
Emergency stop erasable	174 175	0 ... 100 [mm]
Multiplication factor for Ky-factor	176	0.001 ... 1.000

Function	Parameter No.	Entry values
Ky-factor for X Y Z IV	177 178 179 180	0.100 ... 10.000
Characteristic kink	181	0 ... 100.000 [%]
Minimum for feed rate override with tapping Maximum for feed rate override with tapping	182 183	0 ... 150 [%]
Minimum voltage for S-Analogue output	184	0 ... 9.999 [V]
Waiting time for cutout of remaining nominal value voltage with error display "Positioning error"	185	0 ... 65.535 [s]
Tool charge position M 92: X-Axis Y-Axis Z-Axis IV-Axis	186 187 188 189	- 30000.000 ... + 30000.000 [mm]
Programming of rpm S = 0 permitted (voltage value of MP 184 may be less)	190	0 $\hat{=}$ S = 0 not permitted 1 $\hat{=}$ S = 0 permitted
Display of current spindle rpm before spindle start	191	0 $\hat{=}$ off 1 = on
Position window for axis IV	192	0.001 ... 0.5 [mm]
PLC: Timer duration for timer 16-31	193 to 208	0 ... 65535 (in units of 20 ms)
Support of PLC-macro-commands	209 to 212	Input value 16 bit coded
"Scaling" cycle effective for 2 or 3 axes	213	0 $\hat{=}$ the programmed scaling factor is effective in the 3 main axes X, Y, Z 1 $\hat{=}$ the programmed scaling factor is only effective in the working plane
<ul style="list-style-type: none"> · Programmed stop with M 06 · Output of M 89 · no axis standstill if only spindle speed is output with a TOOL CALL · no axis standstill with output of an M-function 	214	0 $\hat{=}$ programmed stop with M 06, M 89 normal output at block beginning 1 $\hat{=}$ no programmed stop with M 06, M 89 normal output at block beginning 2 $\hat{=}$ programmed stop with M 06, M 89 modal cycle call at block end 3 $\hat{=}$ no programmed stop with M 06, M 89 modal cycle call at block end 4 ... 7 if 4 is added to the above entry value then no axis standstill effected with output of spindle speed 8 ... 11 if 8 is added to the above entry value then no axis standstill effected with M-functions Exceptions: no axis standstill effected with M-functions which are followed by a programmed halt (such as M 00, M 02) or with a STOP or CYCL CALL block

Function	Parameter No.	Entry values
Touch probe system probing speed	215	80 ... 3000 [mm/min]
Touch probe system measuring distance	216	0 ... 19999.999 [mm]
Switchover HEIDENHAIN dialogue programming	217	0 ≙ HEIDENHAIN-dialogue 1 ≙ ISO (G-codes)-format
ISO (G-code)-programming "Transfer blockwise"	218	0 ... 65 535
ASCII-characters for data input "Transfer blockwise"	219	0 ... 65 535
ASCII-characters for data output "Transfer blockwise"	220	0 ... 65 535
ASCII-characters for beginning and end of heading block "Transfer blockwise"	221	0 ... 65 535
ASCII-characters for transmission correction or block repetition	222	0 ... 255
Data format and transmission stop for data interface V.24 (RS-232-C)	223	0 ≙ "Standard data interface" 1 ≙ "Transfer blockwise"
"Transfer blockwise" ASCII-character, data transmission end	224	0 ... 255
Central tool memory	225	0 ≙ no central tool memory 1 ... 99 ≙ central tool memory with number of tool stores
Graphics hard copy printout Number of command characters for setting the printer interface + 1 command character	226	0 ... 65 535
Graphics hard copy printout 2 each of characters for setting the printer interface	227 228 229	0 ... 65 535
Graphics hard copy printout Number of command characters before each print line + 1 command character	230	0 ... 65 535
Graphics hard copy printout 2 each of characters before every print line	231 232 233	0 ... 65 535
Movement supervision	234	0.03 ... 10 [V]
Touch probe system: safety distance above measuring point for automatic probing	235	0 ... 19 999.999 [mm]

Function	Parameter No.	Entry values
Graphics	236 bit	
Projection of graphics image 3 planes	0	0 ≙ German standard +1 ≙ American standard
Turning of coordinate system in the machining plane by 90°	1	0 ≙ no turning +2 ≙ coordinate system turned
Spindle orientation axis	237	0 ≙ axis not active 1 ≙ axis serves for orientation of main spindle, without position display 2 ≙ as entry value 1, however, with position display (displayed instead of IV-axis) 3 ≙ V-axis not controlled, however, position display, axis designation A (displayed instead of IV-axis) 4 ≙ as entry value 3, however, axis designation B 5 ≙ as entry value 3, however, axis designation C
Kv-factor for V-axis	238	0,100 ... 10.00
Counting direction and reference pulse for spindle orientation axis	239 bit	
Counting direction	0	0 ≙ positive counting direction +1 ≙ negative counting direction
Reference pulse inhibition	1	0 ≙ not active +2 ≙ active
Position value on reference mark for V-axis	240	0 ... 360.000
Cycles for milling pockets with various contours	241 bit	
Cycle "ROUGH-OUT": milling direction for pilot milling of contours	0	0 ≙ pilot milling of countour with pocket ccw, with islands cw +1 ≙ pilot milling of countour with pocket cw, with islands ccw
Cycle "ROUGH-OUT": sequence for roughing and pilot milling	1	0 ≙ first mill a canal around the contour, then rough-out the pocket +2 ≙ first rough-out the pocket, then mill a canal around the contour
Combining corrected or uncorrected contours	2	0 ≙ combining corrected contours +4 ≙ combining uncorrected contours
Reference mark spacing for distance-coded HEIDENHAIN linear transducers	X 242 Y 243 Z 244 IV 245	0 ... 65535 0 ≙ no distance-coded reference marks 1000 ≙ encoder with 20 µm grating pitch.
Positioning window for V-axis	246	0 ... 65535 (increments)
Hysteresis for electronic handwheel	247	0 ... 65535 (increments)
Spindle speed for spindle orientation	248	0 ... 99999.999 [U/min]
Setting of 16 markers to binary number (markers 2208 to 2223)	249	0 ... 65535
Setting of 16 markers to binary markers 2224 to 2234)	250	0 ... 65535
As of Software version 02 Rapid for automatic probing cycle	251	180 ... 15999 [mm/min]
Cyclic Offset alignment for nominal value outputs	252	0 ... 65535 (in 20 ms-units) 0 ≙ no cyclic Offset alignment

Machine-Parameters 71, 218, 219, 220, 221, 222, 223 and 224 are only effective if the data interface has been switched to EXT via MOD.

Function	Parameter No.	Entry values
Allotment of measuring system plugs to the axes	253 254 255 256 257	0 ... 5 Input 0 $\hat{=}$ standard allotment
Analog issue of spindle slewing speed: Slewing speed for the spindle, in case marker 2501 is set.	258	0 ... 99999.999 rpm Direction of rotation is always positive.
Language-change for user cycles Difference between dialog numbers of the first and second dialog languages	259	0 ... 50
without function	260 261 262	0
Difference between Q parameter numbers for "DLG-DEF" block and "DLG CALL" block	263	0 ... 50

Notes:

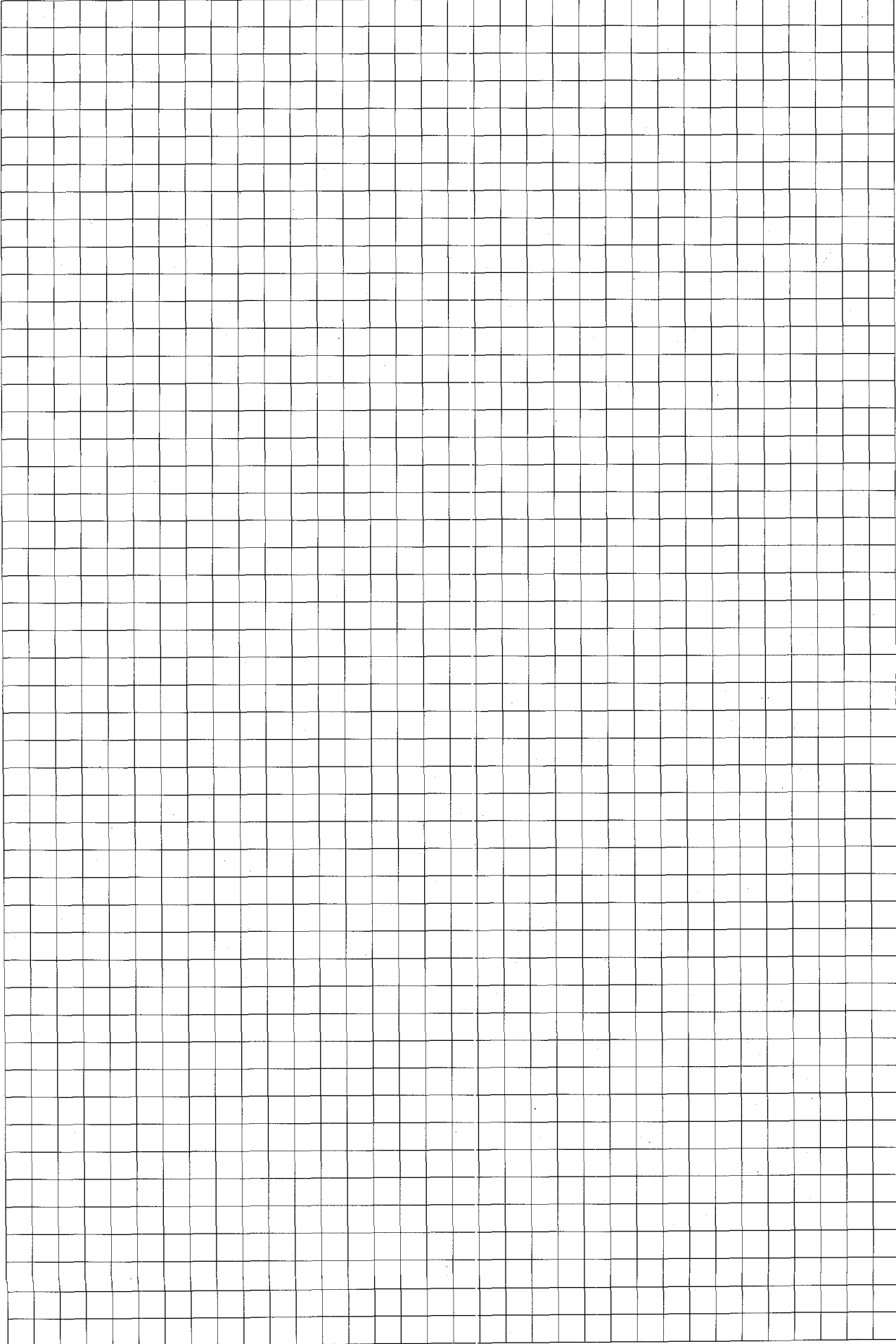
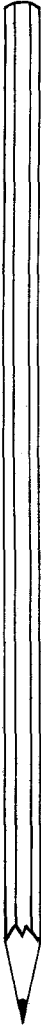

G) List of markers for signal exchange between PLC and NC

Note:

Markers M 1900 to M 1999 are either user-markers or markers for signal exchange between the PLC and NC – depending on marker 2496 (see section C 2.2.4.2).

Marker No.	Function
2000	Release X-axis
2001	Release Y-axis
2002	Release Z-axis
2003	Release IV-axis
2004	"0" = Analogue voltage for spindle drive is located in ramp
2005	"1" = Analogue voltage for spindle drive is 0 V
2008	X-axis in position
2009	Y-axis in position
2010	Z-axis in position
2011	IV-axis in position
2012	Lubrication impulse necessary X-axis limit exceeded
2013	Lubrication impulse necessary Y-axis limit exceeded
2014	Lubrication impulse necessary Z-axis limit exceeded
2015	Lubrication impulse necessary IV-axis limit exceeded
2023	Stylus already deflected at start of probing cycle
2024	Probing system ready (TS 510)
2025	Stylus deflected. Probing procedure completed
2026	Probing procedure completed
2027	Battery voltage too low (TS 510)
2032	1. Bit T-Code (lsb)
2033	2. Bit T-Code
2034	3. Bit T-Code
2035	4. Bit T-Code
2036	5. Bit T-Code
2037	6. Bit T-Code
2038	7. Bit T-Code
2039	8. Bit T-Code (msb)
2041	English dialogue language is selected
2042	Control operates with S-analogue
2043	Change signal G-Code for S-analogue
2044	Change signal S-Code
2045	Change signal M-Code
2046	Change signal T-Code
2047	Change signal 2. T-Code (see machine parameter 157)
2048	Tapping cycle is called
2050	Programming
2051	Manual operation
2052	Electronic handwheel
2053	Positioning with MDI
2054	Program run single block
2055	Automatic
2056	Program test
2057	Approach to reference point (as of software version 05)
2064	1. Bit S-Code (lsb)
2065	2. Bit S-Code
2066	3. Bit S-Code
2067	4. Bit S-Code
2068	5. Bit S-Code

Marker No.	Function
2069	6. Bit S-Code
2070	7. Bit S-Code
2071	8. Bit S-Code (msb).
2072	1. Bit M-Code (lsb)
2073	2. Bit M-Code
2074	3. Bit M-Code
2075	4. Bit M-Code
2076	5. Bit M-Code
2077	6. Bit M-Code
2078	7. Bit M-Code
2079	8. Bit M-Code (msb)
2080	1. Bit for minimum rpm (lsb)
2081	2. Bit for minimum rpm
2082	3. Bit for minimum rpm
2083	4. Bit for minimum rpm
2084	5. Bit for minimum rpm
2085	6. Bit for minimum rpm
2086	7. Bit for minimum rpm
2087	8. Bit for minimum rpm (msb)
2088	1. Bit for step width (lsb)
2089	2. Bit for step width
2090	3. Bit for step width
2091	4. Bit for step width (msb)
2096	TNC axis-button last pressed X
2097	TNC axis-button last pressed Y
2098	TNC axis-button last pressed Z
2099	TNC axis-button last pressed IV
2100	X-axis is tool axis
2101	Y-axis is tool axis
2102	Z-axis is tool axis
2103	IV-axis is tool axis
2104	1. Bit gear change Code S-Analogue (lsb)
2105	2. Bit gear change Code S-Analogue
2106	3. Bit gear change Code S-Analogue (msb)
2176	Code operating mode (lsb)
2177	Code operating mode
2178	Code operating mode
2179	Code operating mode (msb) 0000 = Programming 0001 = Manual operation 0010 = Electronic handwheel 0011 = Positioning with MDI 0100 = Program run single block 0101 = Automatic
2180	1. PLC-cycle run after power on
2182	Inhibited TNC-button pressed
2183	Program interruption (flashing of operation display lamp)
2184	Control in operation (permanent operation pilot)
2185	1. PLC-cycle run after interruption of PLC-program
2189	Undefined macro called
2190	Erasable error display is displayed
2191	Error "external emergency stop" is displayed
2192	Markers influenced by machine parameter 158 (value 1)
2193	(value 2)

Marker No.	Function
2194	(value 4)
2195	(value 8)
2196	(value 16)
2197	(value 32)
2198	(value 64)
2199	(value 128)
2200	(value 256)
2201	(value 512)
2202	(value 1024)
2203	(value 2048)
2204	(value 4096)
2205	(value 8192)
2206	(value 16384)
2207	(value 32768)
2208	Markers affected by machine parameter 249 (value 1)
2209	(value 2)
2210	(value 4)
2211	(value 8)
2212	(value 16)
2213	(value 32)
2214	(value 64)
2215	(value 128)
2216	(value 256)
2217	(value 512)
2218	(value 1024)
2219	(value 2048)
2220	(value 4096)
2221	(value 8192)
2222	(value 16384)
2223	(value 32768)
2224	markers affected by machine parameter 250 (value 1)
2225	(value 2)
2226	(value 4)
2227	(value 8)
2228	(value 16)
2229	(value 32)
2230	(value 64)
2231	(value 128)
2232	(value 256)
2233	(value 512)
2234	(value 1024)
2235	(value 2048)
2236	(value 4096)
2237	(value 8192)
2238	(value 16384)
2239	(value 32768)
2240	User cycle 68
2241	User cycle 69
2242	User cycle 70
2243	User cycle 71
2244	User cycle 72

Marker No.	Function
2245	User cycle 73
2246	User cycle 74
2247	User cycle 75
2248	User cycle 76
2249	User cycle 77
2250	User cycle 78
2251	User cycle 79
2252	User cycle 80
2253	User cycle 81
2254	User cycle 82
2255	User cycle 83
2256	User cycle 84
2257	User cycle 85
2258	User cycle 86
2259	User cycle 87
2260	User cycle 88
2261	User cycle 89
2262	User cycle 90
2263	User cycle 91
2264	User cycle 92
2265	User cycle 93
2266	User cycle 94
2267	User cycle 95
2268	User cycle 96
2269	User cycle 97
2270	User cycle 98
2271	User cycle 99
2448	NC-Start
2449	NC-rapid
2450	Memory function for manual traversing
2451	Feed release
2452	Start PLC-positioning X-axis
2453	Start PLC-positioning Y-axis
2454	Start PLC-positioning Z-axis
2455	Start PLC-positioning IV-axis
2456	Manual traversing X+
2457	Manual traversing X-
2458	Manual traversing Y+
2459	Manual traversing Y-
2460	Manual traversing Z+
2461	Manual traversing Z-
2462	Manual traversing IV+
2463	Manual traversing IV-
2464	Complemented NC-start
2465	Complemented NC-rapid
2466	Complemented memory function for manual traversing
2467	Complemented feed release
2468	Complemented start PLC-positioning X-axis
2469	Complemented start PLC-positioning Y-axis
2470	Complemented start PLC-positioning Z-axis
2471	Complemented start PLC-positioning IV-axis
2472	Complemented manual traverse X+

Marker No.	Function
2473	Complemented manual traverse X-
2474	Complemented manual traverse Y+
2475	Complemented manual traverse Y-
2476	Complemented manual traverse Z+
2477	Complemented manual traverse Z-
2478	Complemented manual traverse IV+
2479	Complemented manual traverse IV-
2480	Feedback signal gear change code S-Analogue
2481	Feedback S-Code
2482	Feedback M-Code
2483	Feedback T-Code
2484	Feedback 2. T-Code
2485	Status display and sign of analogue output M03
2486	Status display and sign of analogue output M04
2487	Status display M05
2488	NC-Stop
2489	Inversion of analogue voltage
2490	Spindle ccw for gear change
2491	Spindle cw for gear change
2492	Activation position loop inhibit for X-axis
2493	Activation position loop inhibit for Y-axis
2494	Activation position loop inhibit for Z-axis
2495	Activation position loop inhibit for IV-axis
2496	Release marker for decoded M-Code-output via markers 1900 - 1999
2497	Release marker for ascending edges (see Markers 1500 - 1627) and for descending edges (see Markers 1700 - 1827) of PLC-inputs
2499	Inhibit positioning loop for fifth axis. A pre-marker is not required for inhibiting the positioning loop.
2503	Release marker for probing function
2527	Start PLC-positioning of fifth axis
2543	Complementary start of PLC-positioning for fifth axis
2544	Inhibit position loop X-axis
2545	Inhibit position loop Y-axis
2546	Inhibit position loop Z-axis
2547	Inhibit position loop IV-axis
2548	Reset accumulated distance in X-axis for travel-dependent lubrication
2549	Reset accumulated distance in Y-axis for travel-dependent lubrication
2550	Reset accumulated distance in Z-axis for travel-dependent lubrication
2551	Reset accumulated distance in IV-axis for travel-dependent lubrication
2552	Transfer actual position value in position loop X-axis
2553	Transfer actual position value in position loop Y-axis
2554	Transfer actual position value in position loop Z-axis
2555	Transfer actual position value in position loop IV-axis
2556	REF-point end position X-axis
2557	REF-point end position Y-axis
2558	REF-point end position Z-axis
2559	REF-point end position IV-axis

Marker No.	Function
2560*	PLC-positioning X-axis (lsb)
2561*	PLC-positioning X-axis
2562*	PLC-positioning X-axis
2563*	PLC-positioning X-axis
2564*	PLC-positioning X-axis (msb)
2565*	PLC-positioning Y-axis (lsb)
2566*	PLC-positioning Y-axis
2567*	PLC-positioning Y-axis
2568*	PLC-positioning Y-axis
2569*	PLC-positioning Y-axis (msb)
2570*	PLC-positioning Z-axis (lsb)
2571*	PLC-positioning Z-axis
2572*	PLC-positioning Z-axis
2573*	PLC-positioning Z-axis
2574*	PLC-positioning Z-axis (msb)
2575*	PLC-positioning IV-axis (lsb)
2576*	PLC-positioning IV-axis
2577	PLC-positioning IV-axis
2578	PLC-positioning IV-axis
2579	PLC-positioning IV-axis (msb)
2580	PLC-positioning of fifth axis (lsb)
2581	PLC-positioning of fifth axis
2582	PLC-positioning of fifth axis
2583	PLC-positioning of fifth axis
2584	PLC-positioning of fifth axis (msb)
2800	TNC-button code for external address of TNC-buttons (see markers 2855 to 2923 for coding)
2801	TNC-button code for external address of TNC-buttons (see markers 2855 to 2923 for coding)
2802	TNC-button code for external address of TNC-buttons (see markers 2855 to 2923 for coding)
2803	TNC-button code for external address of TNC-buttons (see markers 2855 to 2923 for coding)
2804	TNC-button code for external address of TNC-buttons (see markers 2855 to 2923 for coding)
2805	TNC-button code for external address of TNC-buttons (see markers 2855 to 2923 for coding)
2806	TNC-button code for external address of TNC-buttons (see markers 2855 to 2923 for coding)
2807	TNC-button code for external address of TNC-buttons (see markers 2855 to 2923 for coding)
2808	Strobe for button-code
2809	Strobe for transfer of the numerical value
2810	Data format of numerical value in markers
2811	2560 to 2576
2812	
2815	Flashing error message from PLC
2816	Assignment of numerical value (marker 2560-2576) to Q-parameters Q 100 to Q 107
2817	
2818	

*Markers 2560 to 2576 have a second function: a numerical value which is to be transferred from the PLC to the NC, must be filed in markers 2560 to 2576.

Marker No.	Function	Button code
2855	Button inhibit	0011 1011
2856	Button inhibit	0011 1100
2857	Button inhibit	0011 1101
2858	Button inhibit	0011 1110
2859	Button inhibit	0011 1111
2860	Button inhibit	0100 0000
2861	Button inhibit	0100 0001
2862	Button inhibit	0100 0010
2863	Button inhibit	0100 0011
2864	Button inhibit	0100 0100
2865	Button inhibit	0100 0101
2866	Button to right of inhibit	0100 0110
2867	Button inhibit	0100 0111
2868	Button inhibit	0100 1000
2869	Button inhibit	0100 1001
2870	Button inhibit	Q100 1010
2871	Button inhibit	0100 1011
2872	Button inhibit	0100 1100
2873	Button inhibit	0100 1101
2874	Button inhibit	0100 1110
2880	Button inhibit	0101 0100
2881	Button inhibit	0101 0101
2882	Button inhibit	0101 0110
2883	Button inhibit	0101 0111
2884	Button inhibit	0101 1000
2885	Button inhibit	0101 1001
2886	Button inhibit	0101 1010
2887	Button inhibit	0101 1011
2888	Button inhibit	0101 1100
2889	Button inhibit	0101 1101
2890	Button inhibit	0101 1110
2891	Button inhibit	0101 1111
2892	Button inhibit	0110 0000
2893	Button inhibit	0110 0001
2894	Button inhibit	0110 0010
2895	Button inhibit	0110 0011
2896	Button inhibit	0110 0100
2897	Button inhibit	0110 0101
2898	Button inhibit	0110 0110
2899	Button inhibit	0110 0111
2900	Button inhibit	0110 1000
2901	Button inhibit	0110 1001
2902	Button inhibit	0110 1010
2903	Button inhibit	0110 1011

Marker No.	Function	Button code
2904	Button inhibit	0110 1100
2905	Button inhibit	0110 1101
2906	Button inhibit	0110 1110
2907	Button inhibit	0110 1111
2908	Button inhibit	0111 0000
2909	Button inhibit	0111 0001
2910	Button inhibit	0111 0010
2911	Button inhibit	0111 0011
2912	Button inhibit	0111 0100
2913	Button inhibit	0111 0101
2914	Button inhibit	0111 0110
2915	Button inhibit	0111 0111
2916	Button inhibit	0111 1000
2917	Button inhibit	0111 1001
2918	Button inhibit	0111 1010
2919	Button inhibit	0111 1011
2920	Button inhibit	0111 1100
2921	Button inhibit	0111 1101
2922	Button inhibit	0111 1110
2923	Button inhibit	0111 1111
2924	Error message 0	
2925	Error message 1	
2926	Error message 2	
2927	Error message 3	
2928	Error message 4	
2929	Error message 5	
2930	Error message 6	
2931	Error message 7	
2932	Error message 8	
2933	Error message 9	
2934	Error message 10	
2935	Error message 11	
2936	Error message 12	
2937	Error message 13	
2938	Error message 14	
2939	Error message 15	
2940	Error message 16	
2941	Error message 17	
2942	Error message 18	
2943	Error message 19	
2944	Error message 20	
2945	Error message 21	
2946	Error message 22	
2947	Error message 23	

GRAPHICS
(for TNC 155)

Marker No.	Function
2948	Error message 24
2949	Error message 25
2950	Error message 26
2951	Error message 27
2952	Error message 28
2953	Error message 29
2954	Error message 30
2955	Error message 31
2956	Error message 32
2957	Error message 33
2958	Error message 34
2959	Error message 35
2960	Error message 36
2961	Error message 37
2962	Error message 38
2963	Error message 39
2964	Error message 40
2965	Error message 41
2966	Error message 42
2967	Error message 43
2968	Error message 44
2969	Error message 45
2970	Error message 46
2971	Error message 47
2972	Error message 48
2973	Error message 49
2974	Error message 50
2975	Error message 51
2976	Error message 52
2977	Error message 53
2978	Error message 54
2979	Error message 55
2980	Error message 56
2981	Error message 57
2982	Error message 58
2983	Error message 59
2984	Error message 60
2985	Error message 61
2986	Error message 62
2987	Error message 63
2988	Error message 64
2989	Error message 65
2990	Error message 66
2991	Error message 67
2992	Error message 68
2993	Error message 69

Marker No.	Function
2994	Error message 70
2995	Error message 71
2996	Error message 72
2997	Error message 73
2998	Error message 74
2999	Error message 75
3000	Error message 76
3001	Error message 77
3002	Error message 78
3003	Error message 79
3004	Error message 80
3005	Error message 81
3006	Error message 82
3007	Error message 83
3008	User-parameter 16
3009	User-parameter 15
3010	User-parameter 14
3011	User-parameter 13
3012	User-parameter 12
3013	User-parameter 11
3014	User-parameter 10
3015	User-parameter 9
3016	User-parameter 8
3017	User-parameter 7
3018	User-parameter 6
3019	User-parameter 5
3020	User-parameter 4
3021	User-parameter 3
3022	User-parameter 2
3023	User-parameter 1



HEIDENHAIN