

**APRON ASSEMBLY  
5900-23  
INCLUDES PAGE 33**

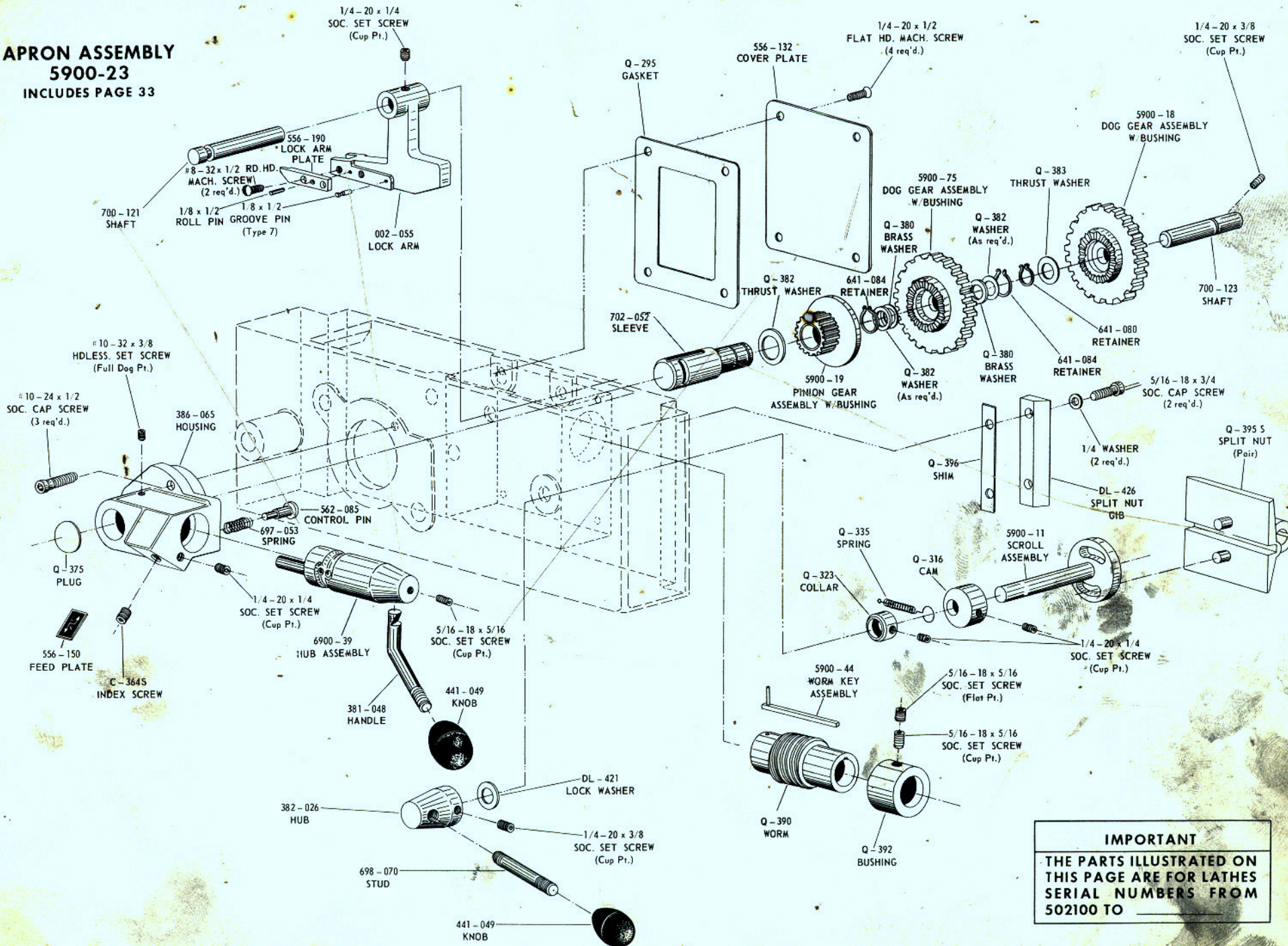

**IMPORTANT**  
THE PARTS ILLUSTRATED ON THIS PAGE ARE FOR LATHES SERIAL NUMBERS FROM 502100 TO \_\_\_\_\_