



DIVISION, ATLAS PRESS COMPANY
KALAMAZOO, MICHIGAN 49001

**INSTALLING CONVERSION
MOTOR VARIABLE PULLEY
CYLINDER ASSEMBLY**

ON
CLAUSING

5900 SERIES LATHES UNDER
SERIAL NO. 505856

6900 SERIES LATHES UNDER
SERIAL NO. 602228

JUNE 1968

FILE NO. 5900-132-2

1.1
2.1

**REMOVING
MOTOR VARIABLE PULLEY HYDRAULIC CYLINDER**

1. Remove lower drive guard cover.
2. With lathe running turn variable speed dial to highest speed (2000 for 5900 and 1650 for 6900).
3. Turn lathe off.

CAUTION: LATHE MUST BE IN HIGHEST RANGE

4. Disconnect fitting (A, fig. 1) and drain small amount of oil remaining in line, into container.

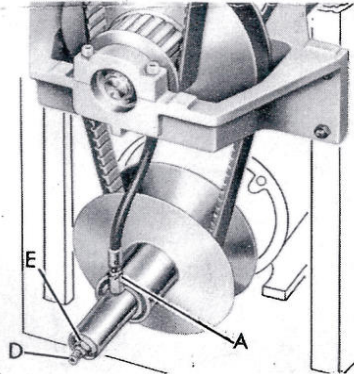

FIGURE 1

NOTE: If lathe is 5900 series with serial number under 502100, disconnect straight fitting on old cylinder and exchange it with elbow fitting on new cylinder.

5. While holding shaft (D, fig. 1) with socket set screw wrench, remove nut (E) and washer.

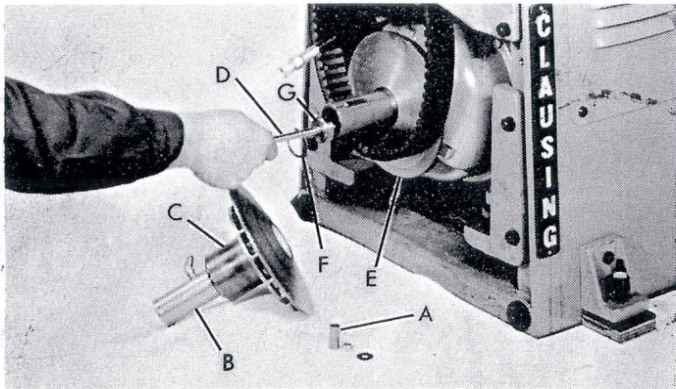

FIGURE 2

6. Remove sleeve (A, fig. 2) from hydraulic cylinder.
7. Pull hydraulic cylinder (B) with outer half of variable pulley (C) off shaft (D).
8. Press hydraulic cylinder (B) with bearing from outer half of variable pulley (C) being sure internal washer in pulley (snap ring on early models) remains in place.

CAUTION: Washer (snap ring on early models) must be in place in outer half of variable pulley (C, fig. 2) before installing bearing and housing assembly (A, fig. 4). An extra washer is supplied to aid in assembly if necessary.

9. With snap ring pliers, remove snap ring (F, fig. 2) from inner half of variable pulley.
10. Remove shaft (D) and bearing (G) from inner half of variable pulley (E).

**REPLACING
MOTOR VARIABLE PULLEY HYDRAULIC CYLINDER**

1. Remove small hydraulic cylinder cover from lower guard and increase the size of the rectangular opening to dimensions in figure 3.

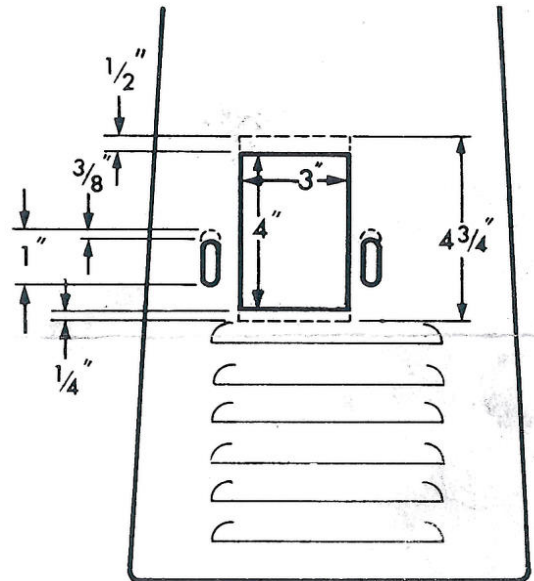

5900 AND 6900 SERIES LATHES

FIGURE 3

NOTE: On 5900 series lathes under serial number 502100, its not necessary to follow step 1 above.

2. Insert new shaft and collar assembly (D, fig. 4) into inner half of variable pulley (E) being sure pin in the collar lines up with key way in pulley (E), secure with retainer ring.

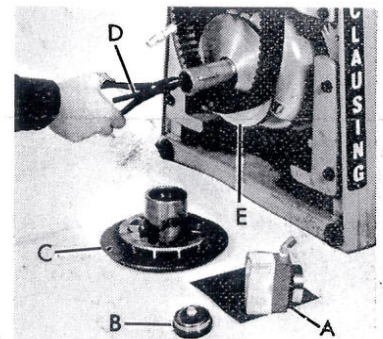

FIGURE 4

3. Press new hydraulic cylinder (A) assembled (less outer bearing assembly B) into outer half of variable pulley (C).

591-3030

- Slide outer half of variable pulley (C, fig. 5) with hydraulic cylinder assembly (A) onto shaft (D) and inner half of variable pulley (E) being sure key and key way in pulley line up.

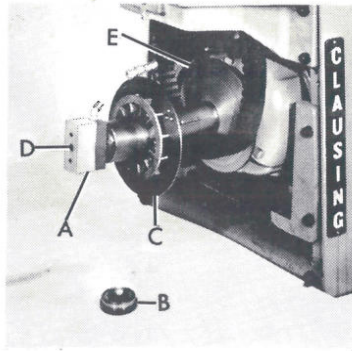

FIGURE 5

- Slide outer bearing assembly, consisting of bearing holder, outer bearing, bearing spacer and locknut (B, fig. 5) onto shaft (D).

CAUTION: BE SURE HOLES IN BEARING HOLDER LINE UP WITH PISTON PILOTS.

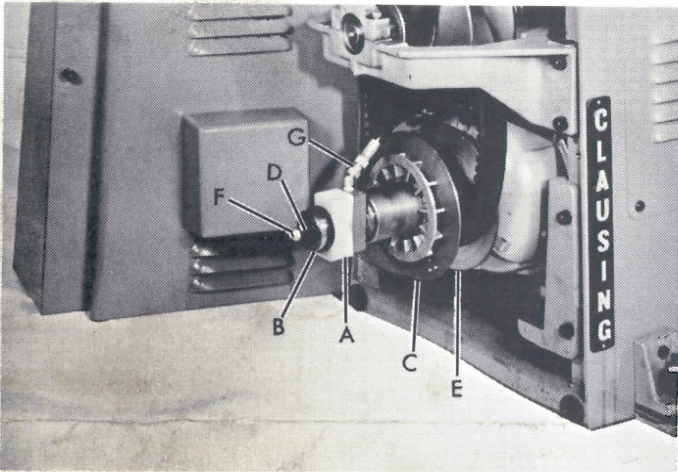

FIGURE 6

- Hold variable pulley (C, fig. 6) so it will not rotate. Turn locknut (F) until approximately 1/8" of shaft (D) extends beyond locknut.

- Start fitting (G) onto elbow.

DO NOT TIGHTEN FITTING (G).

- Fill oil reservoir.

- Keep oil reservoir filled, turn variable speed dial back to low speed stop and hold until oil runs out around fitting (G).

- Tighten fitting (G).

- Start lathe motor. Leave variable control against low speed stop for 30 seconds - turn variable dial to highest speed and bleed air from upper cylinder by loosening small screw on top. Retighten bleeder screw.

CAUTION: LOOSEN SCREW JUST ENOUGH TO ALLOW AIR TO BLEED OUT.

- Turn variable control back to low speed. Control should stay at setting if air is out of system. If control does not stay at low speed (52/360 rpm) repeat steps 11 and 12.

ADJUSTING VARIABLE DRIVE BELT

- Turn off lathe.

- Hold variable pulley (C, fig. 6) so it will not rotate. Turn locknut (F) - clockwise if speed is too low, counterclockwise if speed is too high.

Belt should be flush with outside of motor pulley at high speed and flush with outside of countershaft pulley at low speed.

NOTE: FILE THIS SHEET WITH INSTRUCTION MANUAL FOR USE WHEN ORDERING REPLACEMENT PARTS.

PARTS LIST HYDRAULIC CYLINDER ASSEMBLY

5900 AND 6900 SERIES LATHES

