

# NO. 7114 TAPER ATTACHMENT

## PARTS LIST

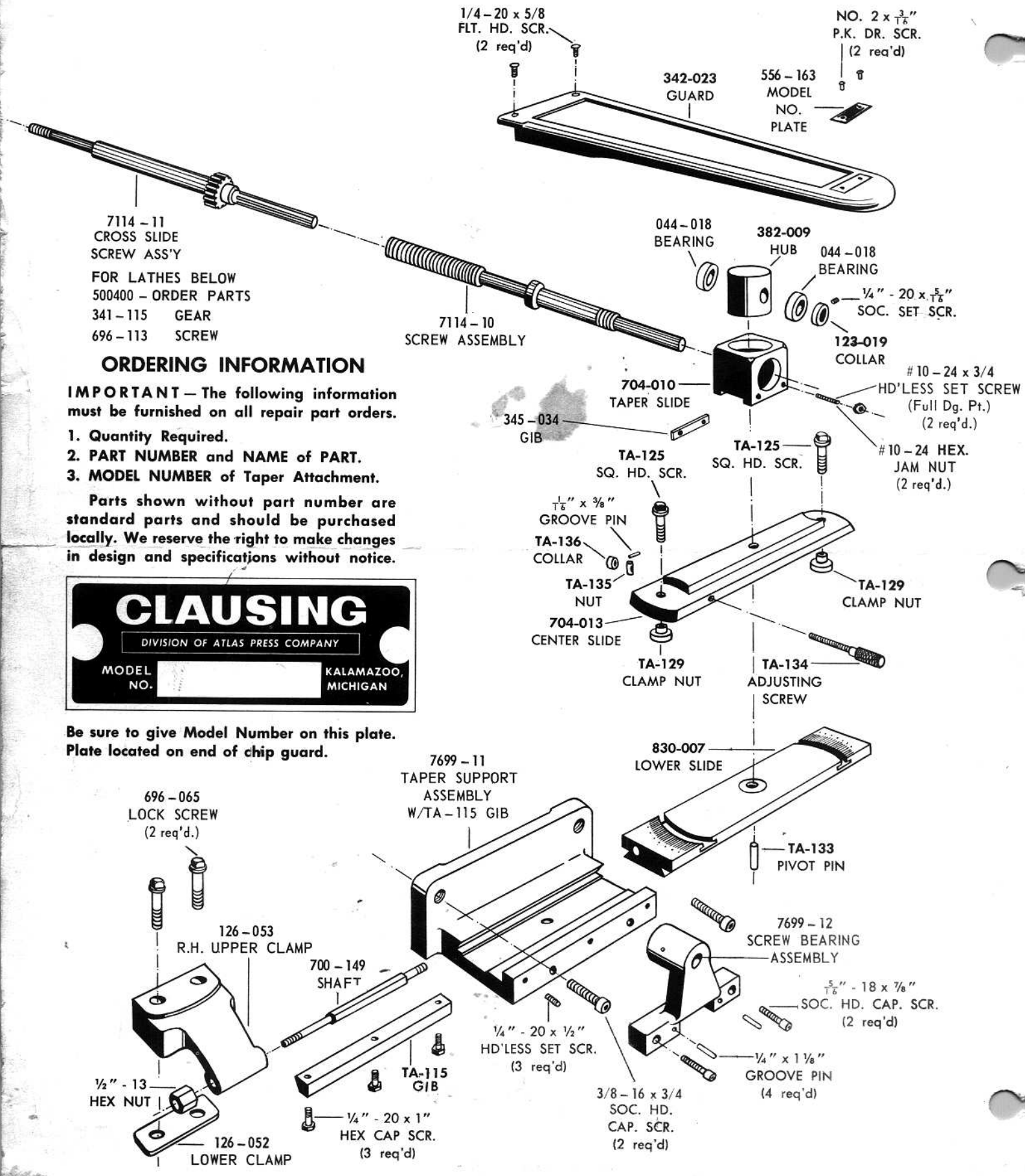

### ORDERING INFORMATION

**IMPORTANT** - The following information must be furnished on all repair part orders.

1. Quantity Required.
2. PART NUMBER and NAME of PART.
3. MODEL NUMBER of Taper Attachment.

Parts shown without part number are standard parts and should be purchased locally. We reserve the right to make changes in design and specifications without notice.

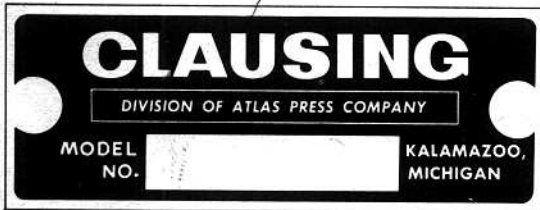

Be sure to give Model Number on this plate. Plate located on end of chip guard.