

OPERATING INSTRUCTIONS
and
PARTS LIST

14
CLAUSING

14-inch LATHES - 6900-series

CLAUSING

DIVISION OF ATLAS PRESS COMPANY

1915-2023 N. PITCHER ST., KALAMAZOO, MICHIGAN - U. S. A.

**This Manual Applies To Clausing 14 " Lathes
From Serial No. 600342 To _____**

CONTENTS

INSTALLATION

Dimension Drawing 2.1
 Foundation 3.1
 Cleaning 3.1
 Moving and Lifting 3.1
 Electrical Connections 4.1
 Anchoring 4.1
 Leveling 4.1

LUBRICATION

Lubrication Chart 5

OPERATION

Functional Diagram 6
 Back Gear Controls 7
 Spindle Speeds 7
 Headstock 8
 Quick-Change Gear Box 8
 Carriage 8 & 9
 Tool Holders 10
 Tailstock 11
 Chucks and Face Plates 11

MAINTENANCE AND ADJUSTMENTS

Preventive Maintenance 12.1
 Clutch Adjustment 12.1
 Carriage Bearing Plates 12.1
 Gibs 12.1
 Countershaft Pulley Alignment 12.1
 Shear Pin 13
 Spindle Bearings 13
 Variable Belt 14.1 & 15.1
 Timing Belt 15
 Upper Variable Control Cylinder 16
 Lower Variable Control Cylinder 16

PARTS INDEX & INSTRUCTIONS FOR ORDERING PARTS 17.3-34

ATTACHMENTS 35

TABLES I

GENERAL DIMENSIONS — 6900 SERIES CLAUSING LATHES

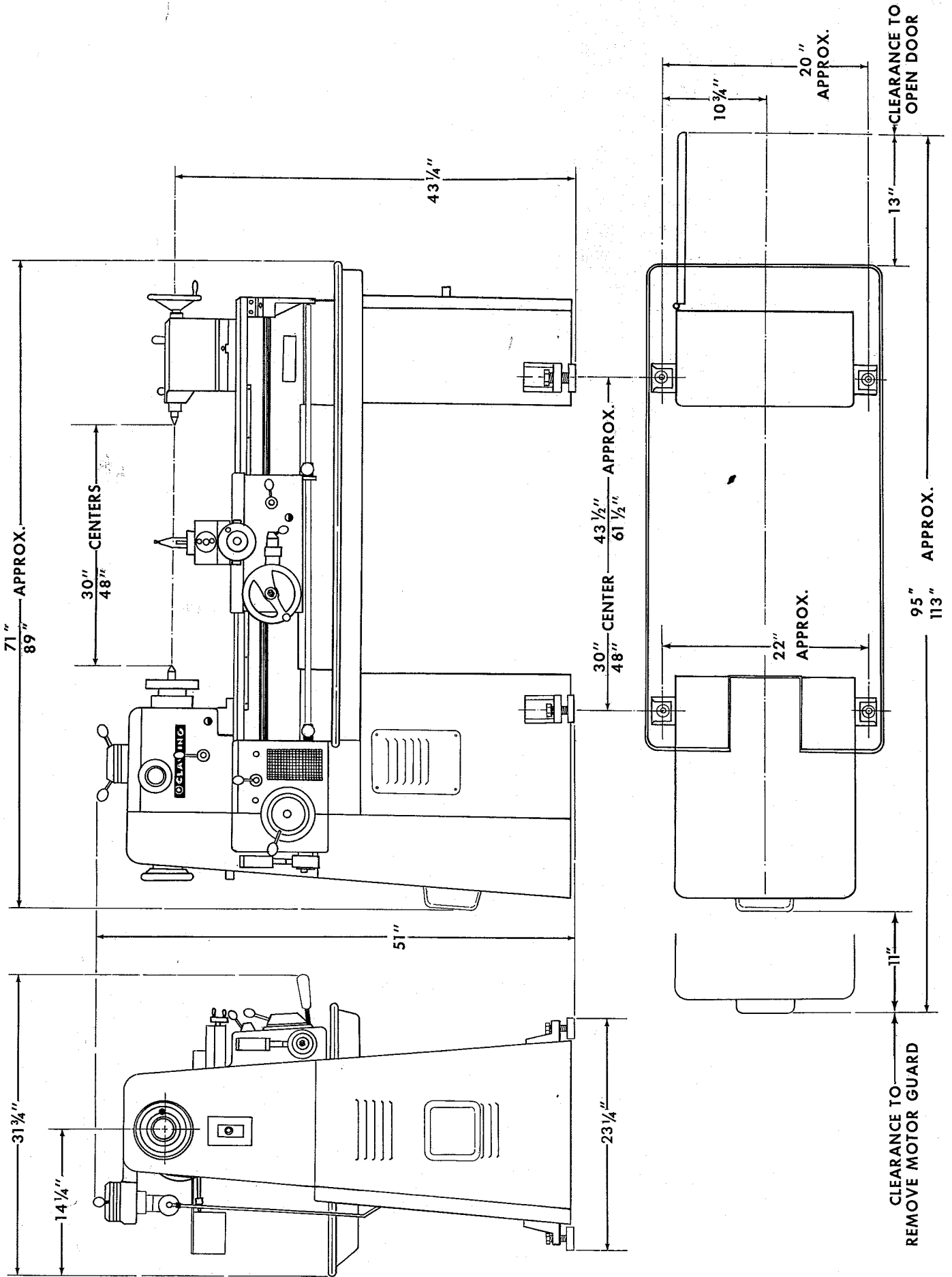



DIVISION, ATLAS PRESS COMPANY
KALAMAZOO, MICHIGAN 49001

WIRING INSTRUCTIONS

for
6900 SERIES
CLAUSING LATHES

SEPTEMBER 1963 FILE NO. 710-042-1

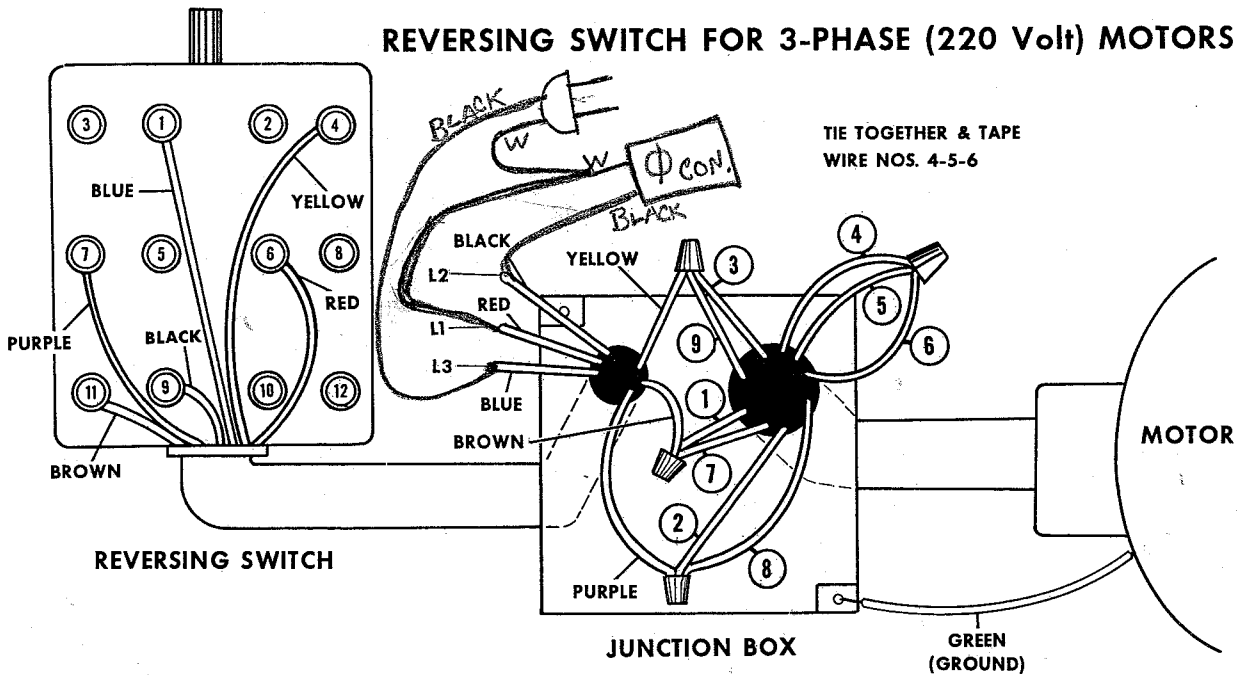

NOTE: TO REVERSE ROTATION OF MOTOR INTERCHANGE ANY TWO LINE LEADS L1, L2 OR L3.

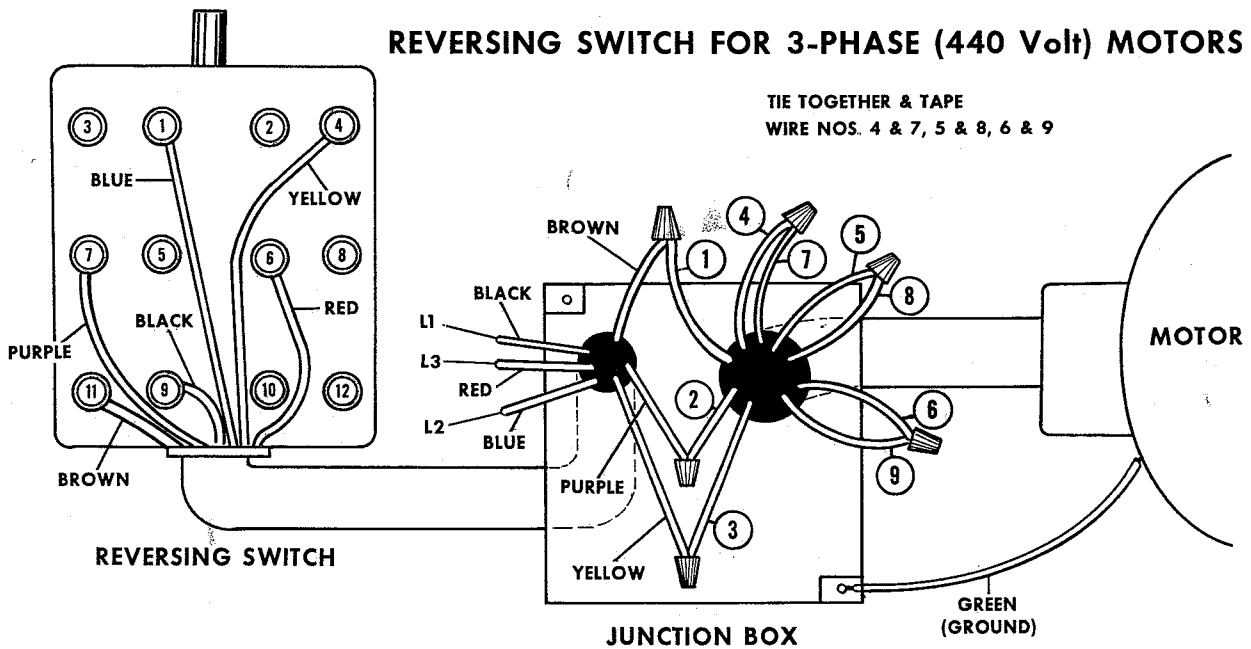

INSTALLATION

FOUNDATION

Your Clausing lathe is a precision machine tool, and requires a solid foundation. The floor must be heavy enough to support the weight of the machine without noticeable deflection, and it must be level. If the floor does not meet these important requirements, a special foundation should be built.

CONCRETE FLOORS -- A reinforced concrete floor is the best foundation: it provides a rigid base, minimizes vibration from adjacent machines, and resists deflection.

WOOD FLOORS should be carefully checked for strength -- place a precision level on floor where lathe is to be located, and move a hand truck with average load past it. If bubble in level shows noticeable movement, the floor should be reinforced, or cut away and a concrete foundation installed.

CLEANING

Before moving carriage or tailstock along the ways, use a good grease solvent to remove the rust-proof coating applied to all polished and unpainted surfaces.

Do not use an air hose -- it could force dirt or grit picked up during transit into bearing surfaces.

Use a stiff bristle brush to clean lead screw.

When thoroughly cleaned, cover the unpainted surfaces with a light coating of "Way Lubricant" for proper lubrication.

Frequent cleaning and lubrication is essential to long service life -- see page 5 for instructions.

MOVING AND LIFTING

Leave lathe on skid -- simplifies moving to final location.

IMPORTANT: DO NOT slide lathe along floor.
DO NOT USE fork lift under chip pan.

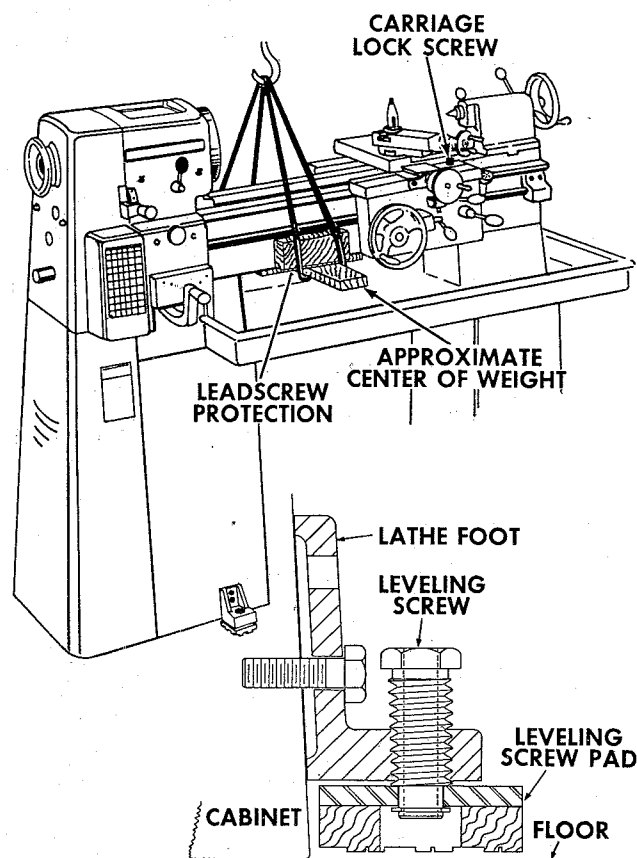

Figure 1

CAUTION: DO NOT LOWER LEVELING SCREW PADS UNTIL LATHE IS READY TO BE LEVELED -- refer to figure 1.

When using a sling -- clean bed ways, move tailstock to the right-hand end of the bed and lock it in place. To protect lead screw and bed, place a 3/4" thick hardwood board under approximate center of weight load, insert sling as shown in figure 1, and raise machine about one-inch off floor. Make any necessary adjustments for balance by moving carriage along bed. -- Before moving carriage, loosen lock screw -- located on top right side of the carriage.

If a fork lift is used, place 3/4" thick hardwood board under the bed so that the clutch rod will not be bent when the lathe is raised -- do not pick up by chip pan.

Mounting pads do not require anchoring.

Leveling screws are equipped with non-slip mounting pads which eliminate the need for anchoring or bolting machine to floor. Floor must be clean and free of oil.

ELECTRICAL CONNECTIONS

The machine is wired at factory -- merely connect power supply to line leads in junction box on back of headstock cabinet. **IMPORTANT:** To reverse rotation of motor interchange any two line leads -- see WIRING INSTRUCTIONS.

Before connecting motor, make sure that voltage and other current requirements of the motor correspond with your power supply. If there is any question, verify your current and voltage by calling your power company.

ANCHORING LATHE TO FLOOR

CAUTION: DO NOT SLIDE LATHE ALONG FLOOR.

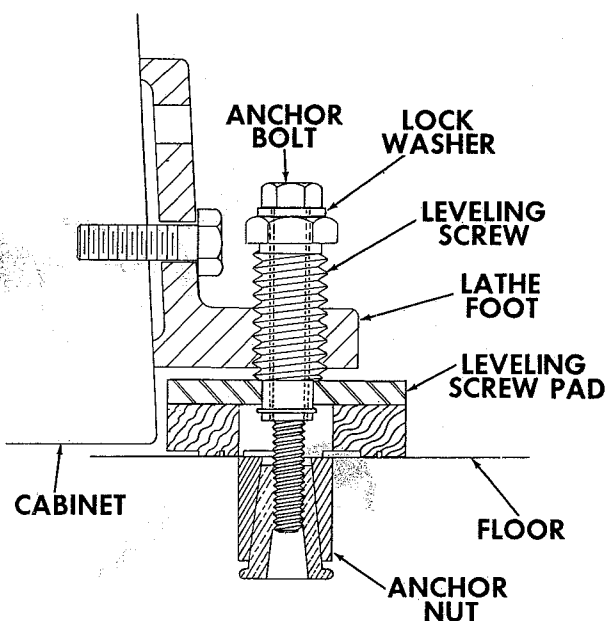

Figure 2

Use anchor bolts to secure lathe to concrete floor -- use lag screws to secure lathe to wood floor -- refer to figure 2.

With a hoist or lift, lower the lathe into position and mark the four leveling screw locations. **DO NOT LOWER LEVELING SCREW PADS.**

Lift machine out of the way, drill holes for anchor nuts and install anchor nuts -- for lag screws drill pilot holes.

Position and lower machine. Turn leveling screws until *no portion* of the lathe cabinet *touches the floor* -- shim under pads, if necessary.

Start anchor bolts or lag screws -- **DO NOT** tighten until lathe is level -- see Leveling Instructions.

LEVELING

The lathe should be kept perfectly level at all times. When carelessly mounted, the bed may become twisted. Even a slight amount of twist will move centers out of alignment and result in inaccurate work and excessive wear. Make it a habit to regularly check the level of the bed.

THIS IS IMPORTANT:

Use *one* precision level at least 6" long -- level should show a distinct bubble movement when a .003" shim is placed under one end.

Clean the bed ways thoroughly.

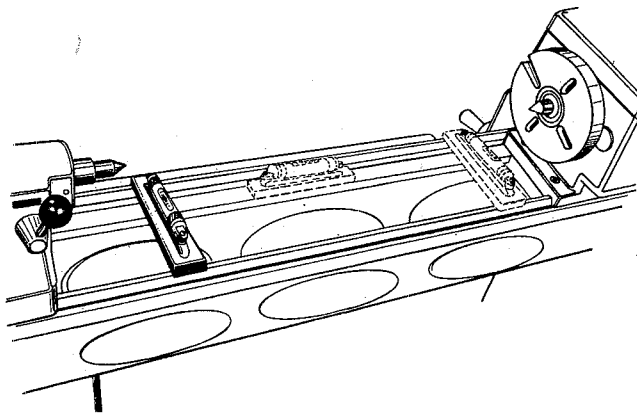

Figure 3

1. First level bed longitudinally, compensate for variations of bubble readings by turning the leveling screws on the cabinet base until bed is level -- refer to Figure 3 for level positions.

2. Next level both ends of the bed. The headstock and the tailstock -- must be checked with the level placed at right angles to the bed. Refer to Figure 3. Use a square to align the level. *Do not turn level end for end.*

Level reading at headstock and tailstock must be identical. Compensate for variations of bubble readings by turning the leveling screws until lathe is level.

NOTE: Avoid excessive adjustment of leveling screws by inserting shims between pads and floor.

3. Tighten the four anchoring bolts *not more than* finger-tight, or until the lock washers start to compress -- lag screws should be tightened, then backed off about one-quarter turn.

4. Recheck the level of the lathe -- unequal tightening of anchoring bolts may have pulled the bed out of level. Recheck leveling in 5 days.

Check level of bed at frequent intervals. Chatter -- turning taper -- boring taper -- facing convex or concave is the general result of an improperly leveled lathe.

LUBRICATION CHART - - - 6900 SERIES CLAUSING LATHES

CODE

D-DAILY oil with Texaco Way Lubricant "D" or equivalent.
W-WEEKLY oil with Texaco Way Lubricant "D" or equivalent.
M-MONTHLY clean with Kerosene, then oil with Texaco Way Lubricant "D" or equivalent.

FREQUENTLY

F1-Check oil level in Window. Remove pipe plug and fill to mark with TEXACO REGAL PC-R&O oil or equivalent.

F2-With motor running and variable dial turned to low speed, fill with TEXACO REGAL PC-R&O oil or equivalent.

F3-With gear engaging lever in down position, check oil level in window. With lever in this position, fill to mark with TEXACO REGAL OIL G or equivalent.

F4-Fill countershaft fitting and grease the two fingers with TEXACO MARFAX H.D.#2 grease or equivalent.

P-PERIODICALLY lubricate quadrant gear teeth with TEXACO CRATER No. 2X fluid or equivalent. Remove oil and dirt before applying.

* Remove plug.

** Remove plug and turn spindle until oiler shows.

*** Remove cover.

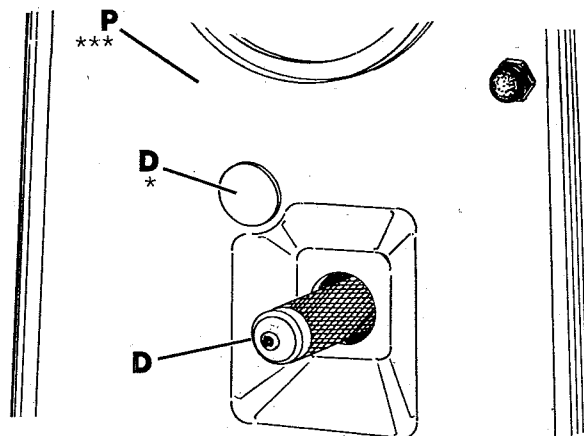
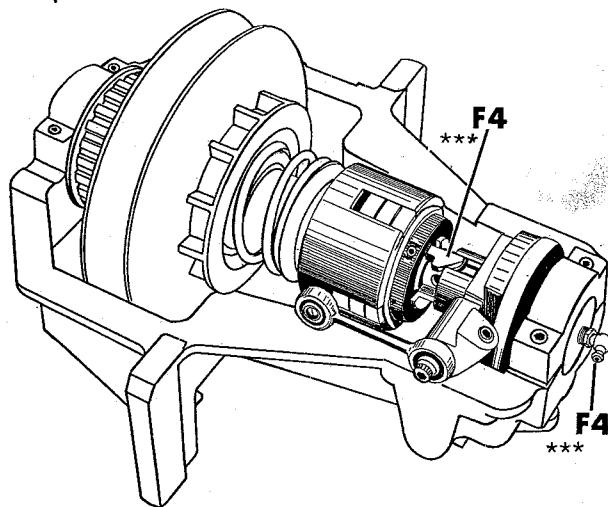
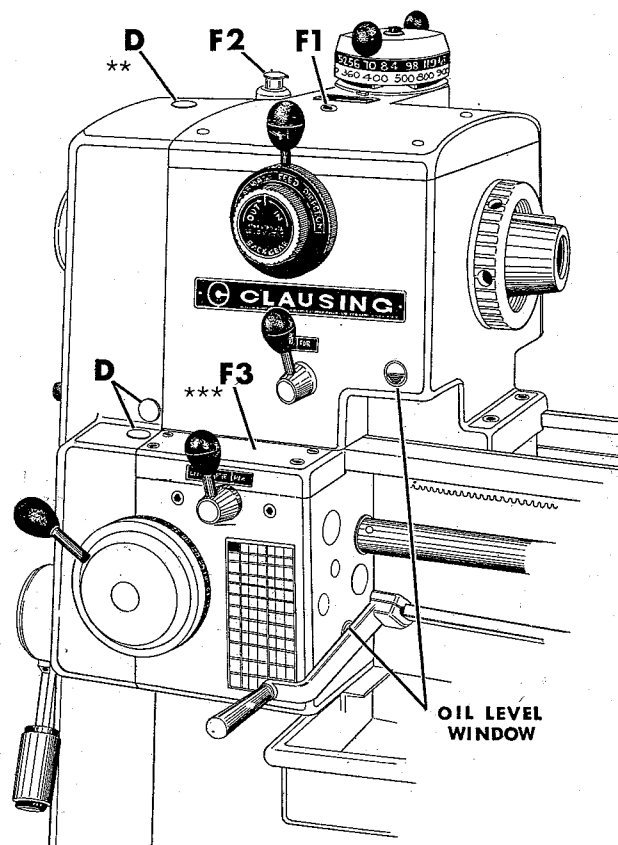
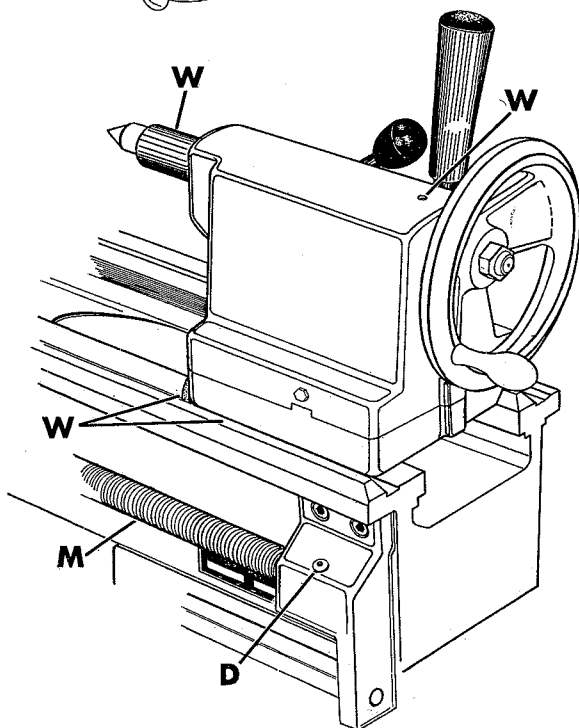
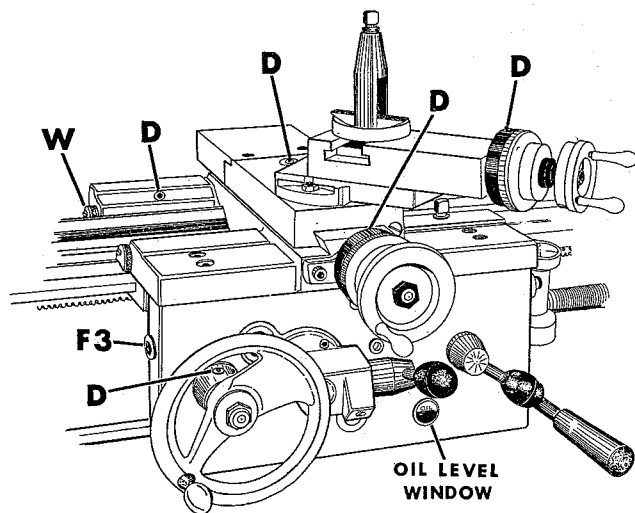

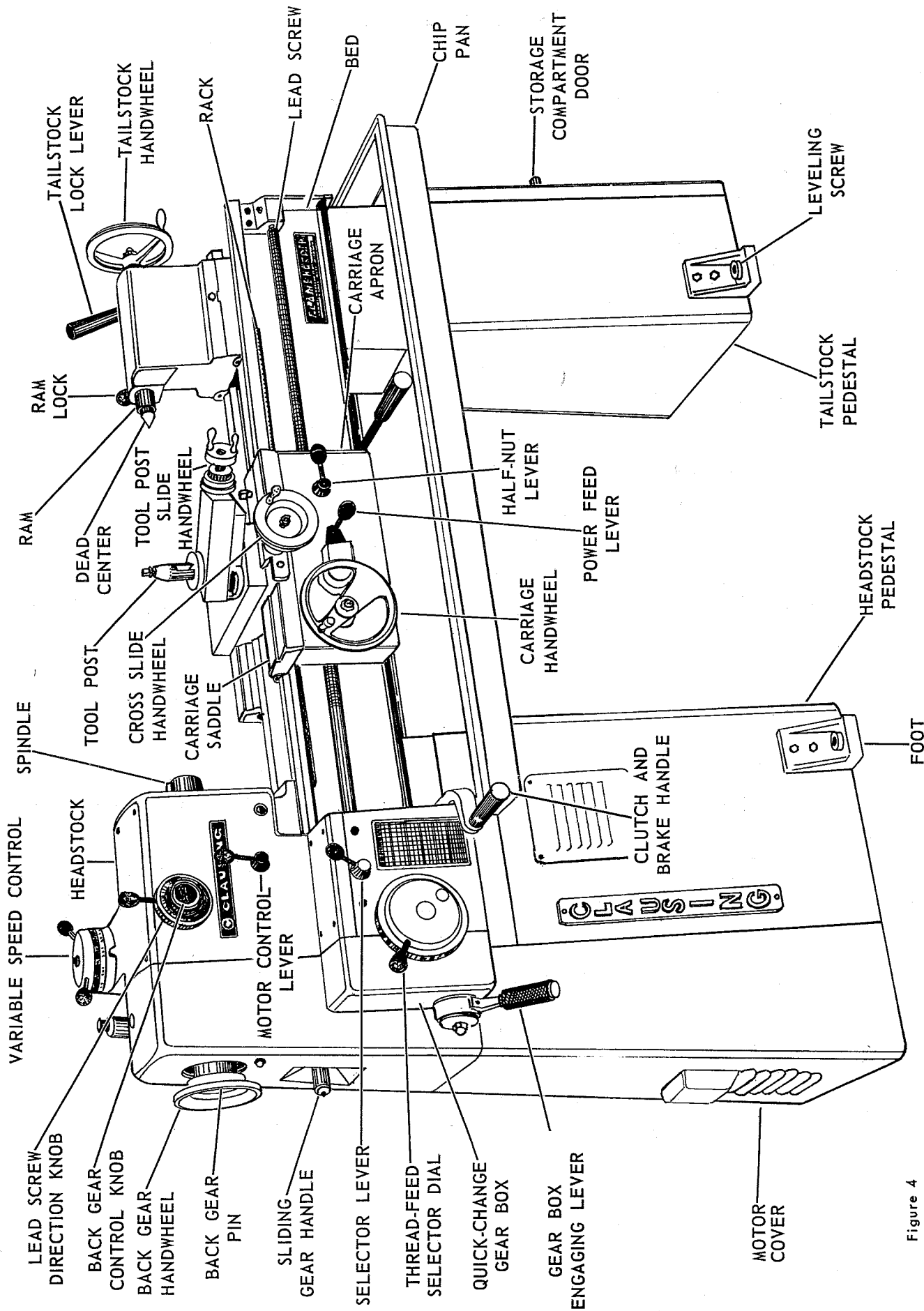

Figure 4

CONTROLS AND OPERATIONS

Do not operate lathe until you are thoroughly familiar with all controls and their functions. The machine is shipped from factory with gears set for direct drive, and carriage locked to bed. Read the instructions carefully. Then, first operate the lathe in back gear -- get the "feel" of the controls -- set up different threads and feeds -- engage the power feeds -- get acquainted with the lathe before you start a job -- it will save time and produce better work.

HEADSTOCK

The totally enclosed headstock houses and supports the spindle, spindle bearings and driving gears. Gears, shafts, bearings and spindle bearings travel in a bath of oil.

BACK GEAR CONTROLS

BACK GEAR DRIVE provides the slow spindle speeds from 43 to 230 rpm required for heavy cuts and correct surface speeds for large diameter work.

IMPORTANT: The back gear knob should not be moved from one position to another unless motor is in "OFF" position. Spindle must come to a complete stop before changing drives.

To engage the back gear drive:

1. Stop lathe spindle.

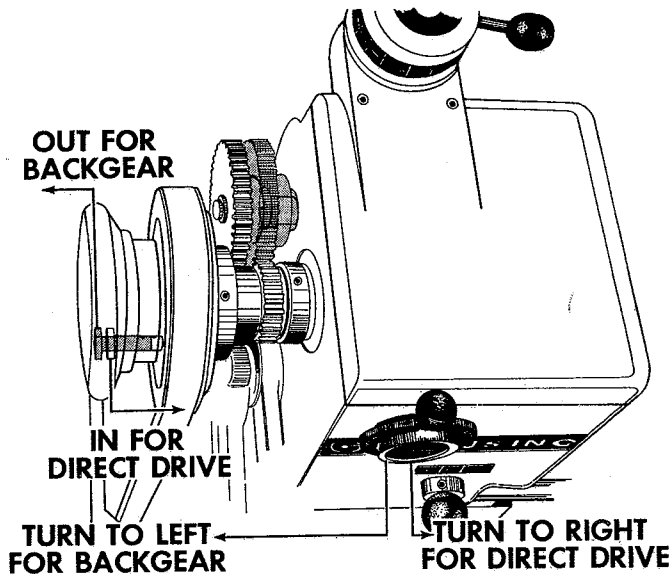

Figure 5

2. Turn back gear knob (figure 5) to the left -- rotate spindle by hand if gears do not mesh.
3. Disengage back gear pin from drive pulley by pulling pin away from headstock.

DIRECT DRIVE provides high spindle speeds from 300 to 1650 rpm.

To engage direct drive:

1. Stop spindle.
2. Turn back gear knob to the right.
3. Engage the back gear pin with drive pulley by pushing pin towards headstock -- rotate wheel if necessary.

SPINDLE SPEEDS

Speeds are changed hydraulically. Control dial, located on top of the headstock, actuates hydraulic system. Speeds -- between 43 and 230 rpm in back gear drive, and 300 to 1650 rpm in direct drive -- are obtained by turning the dial control.

Caution: DO NOT TURN CONTROL DIAL UNLESS MOTOR IS RUNNING -- it makes dial reading incorrect in terms of spindle rpm.

NOTE: Hydraulic system, however, is equipped with a by-pass valve that prevents damage if control dial is accidentally turned while motor is not running.

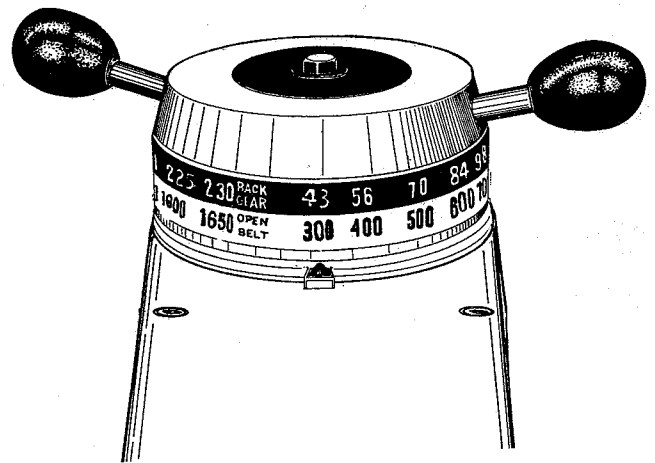

Figure 6

If dial reading is incorrect:

1. Start the motor -- turn variable speed control to 300 rpm (43 rpm if lathe is in back gear) -- refer to figure 6.
2. Hold at this speed, exerting slight pressure for 30 seconds.

QUICK-CHANGE GEAR BOX

Quick-change mechanism determines the rate of rotation of lead screw in relation to the RPM of the spindle for threading, turning, and facing operations. Mechanism is totally enclosed, gears and shafts travel in bath of oil.

See figure 7 for the location of the controls described below.

GEAR BOX ENGAGING LEVER. To disengage, pull out handle of lever and move lever up as far as it will go. To engage, pull out handle of lever and move lever to down position.

IMPORTANT: When lever is in lowest position, stack gears are locked in mesh and thread-feed selector dial cannot be moved.

SLIDING GEAR HANDLE changes the ratio between the spindle and lead screw. There are two positions IN and OUT. *Do not shift while spindle is turning.*

THREAD-FEED SELECTOR DIAL. To operate, disengage gear box engaging lever and turn dial to number indicated on chart.

SELECTOR LEVER has three positions -- C, B or A. To shift, place lead screw direction knob in neutral (center position) and turn sliding gear handle until knob can be engaged -- *do not force.*

CLUTCH AND BRAKE COUNTERSHAFT MODELS

Countershaft has friction clutch and brake for starting, stopping and jogging of spindle without stopping the motor. Moving clutch lever up engages spindle drive -- down disengages it and tightens the brake shoe and stops the spindle -- refer to figure 7.

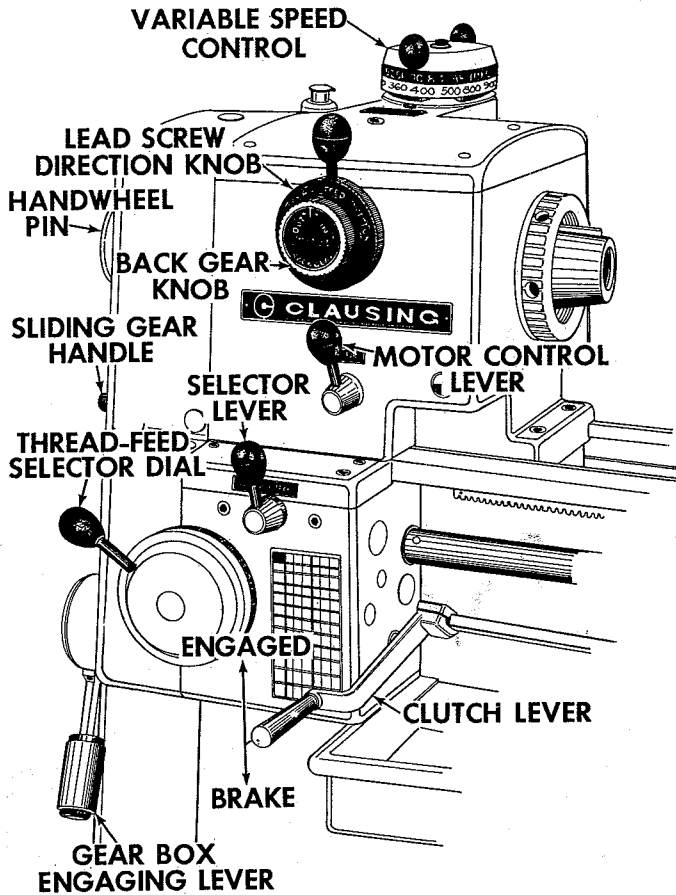

Figure 7

MOTOR CONTROL LEVER located on front of headstock controls rotation of lathe spindle. It has three positions -- REVERSE, OFF, and FORWARD -- refer to figure 7.

To reverse rotation of motor and spindle:

1. Move lever to "OFF" position and allow spindle to stop.
2. Move lever to FORWARD or REVERSE position.

Caution: Always allow spindle to stop before reversing rotation.

LEAD SCREW DIRECTION KNOB has three positions: Vertical is neutral -- lead screw does not turn; Left, moves carriage toward tailstock; Right, moves carriage towards headstock.

CAUTION: Always stop spindle before shifting lead screw direction knob.

CARRIAGE

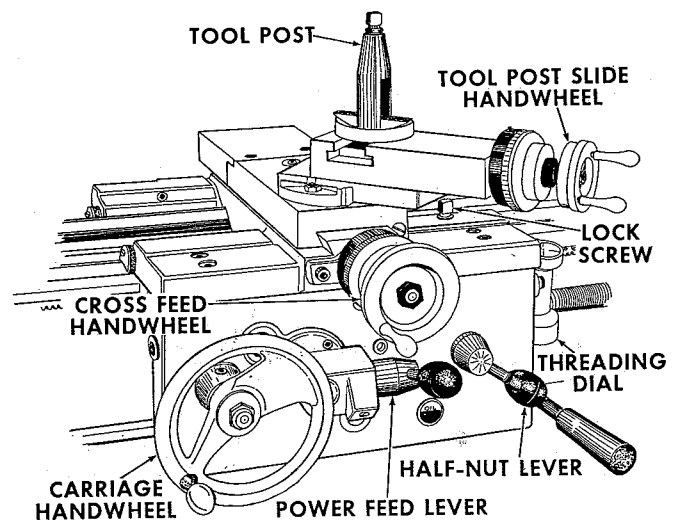

Figure 8

The function of the carriage is to rigidly support the cutting tool, and to move it along or across the bed -- refer to figure 8.

CARRIAGE LOCK SCREW locks carriage to bed for facing or cut-off operations. *Caution:* Be sure to release lock before moving carriage.

CARRIAGE HANDWHEEL moves carriage along the bed manually.

CROSS FEED SLIDE AND COMPOUND REST HANDWHEELS move the cross slide and compound rest in and out.

POWER FEED LEVER controls the operation of both power longitudinal feed and power cross feed. Lever has three positions: center disengages (neutral for hand feeding), to the left and down engages power cross feeds, to the right and up engages power longitudinal feeds.



Caution: The power feed lever and the half-nut lever are interlocked. Half-nuts must be disengaged (half-nut lever in down position) before power feeds can be engaged.

NOTE: Cross feed is $\frac{1}{2}$ of the rate of longitudinal feed.

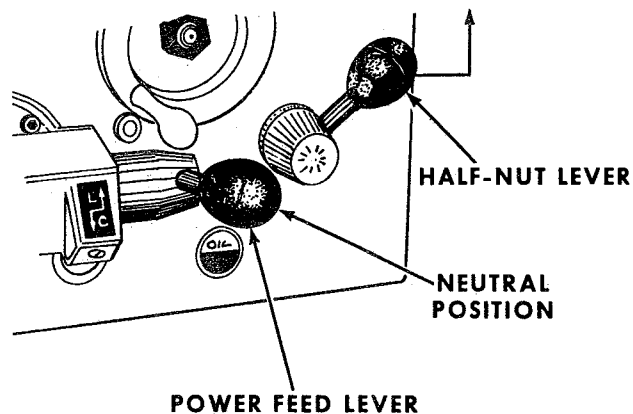

Figure 9

HALF-NUT LEVER engages half-nuts with lead screw for threading -- refer to figure 9.

To engage half-nuts:

1. Move power feed lever to center (disengaged or neutral position).
2. Move half-nut lever to up position.

NOTE: Safety lock prevents engaging feeds and half-nuts at same time -- do not force levers.

Important: Never use half-nuts for power feeds. Using half-nuts for threading only will maintain the accuracy of the lead screw.

THREADING DIAL

The threading dial performs the important function of indicating the proper time to engage the half-nut lever so that tool will enter the same groove of the thread on each successive cut.

To maintain the accuracy of the worm gear, loosen clamp screw and swing threading dial away from lead screw when not threading.

When cutting *even-numbered thread* (such as 12, 14, 16, 32, etc., per inch), engage the half-nut lever for the first cut when the stationary mark on the outside of the threading dial is in line with *any* of the marks on rotating portion of the dial. Any dial marking may be used for successive cuts.

When cutting *odd-numbered thread* (such as 7, 9, 11, 23, 27, etc., per inch), engage the half-nut lever for the first cut and all successive cuts when the stationary mark on the threading dial is in line with *any* of the numbered marks on the dial.

When cutting *half-numbered threads* (such as $4\frac{1}{2}$, $5\frac{1}{2}$, $6\frac{1}{2}$, $11\frac{1}{2}$, etc., per inch), engage the half-nut lever at the *same* number on the threading dial for *each* cut.

The threading dial cannot be used for metric threads. For these, the half-nut is closed on the lead screw, and remains engaged until the thread is completed. After each cut and tool withdrawal, the tool is brought back to starting point by reversing the spindle.

SEQUENCE OF ENGAGING CONTROLS FOR THREADING OR FEEDS

1. Disengage power feed or half-nut lever.
2. Set quick-change mechanism for thread or feed desired:
 - A. Pull out handle of GEAR BOX ENGAGING LEVER and move lever up as far as it will go.
 - B. Turn THREAD-FEED SELECTOR DIAL to the number indicated on chart.
 - C. Position SLIDING GEAR, as indicated on chart.
 - D. Position SELECTOR LEVER to C, B or A, as indicated on chart.
 - E. Pull out handle of GEAR BOX ENGAGING LEVER and move lever down to engaged position.
3. Shift LEAD SCREW DIRECTION KNOB for direction desired.
4. Select drive -- either direct or back gear -- according to spindle speed required.
5. Start motor.

6. Move variable speed control dial to spindle speed desired.
7. Engage carriage controls -- longitudinal power feed lever for feeds, half-nuts for threading.
8. With tool in position, make a "trial run" without touching work to make sure the set up is right.

NOTE: When threading, be sure threading dial is engaged with lead screw.

FOR CLUTCH and BRAKE MODELS -- be sure clutch is disengaged (handle in down position) before starting motor.

TOOL POST

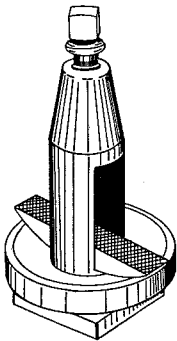

Figure 10

The tool post holds the tool rigidly in position for cutting operations -- refer to figure 10.

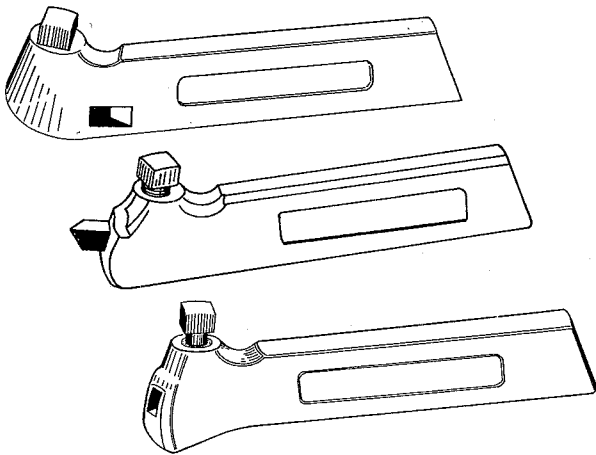

Figure 11

Tool bit holders permit the use of small, inexpensive and replaceable tool bits -- refer to figure 11.

In order to avoid undesirable overhang, tool bits should be clamped so the cutting end of the tool bit is as close to the holder as the work will permit, and, the tool holder should be as far back in the tool post as possible.

The cutting edge of the tool should be placed on lathe center line.

PROPER POSITION OF TOOL POST SLIDE

For maximum tool support, the front edge of the tool post slide should be positioned flush with the front end of the upper swivel.

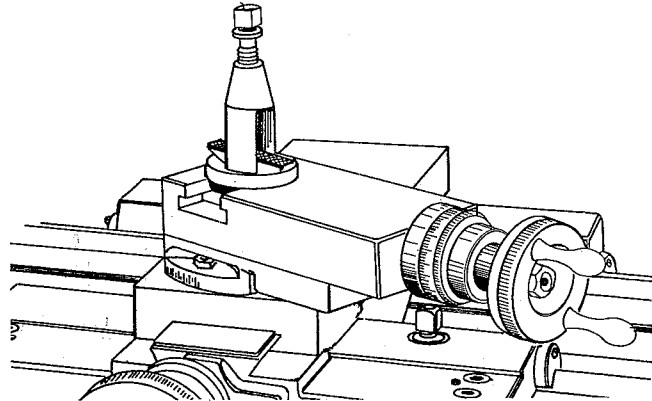

Figure 12

RIGHT -- Tool post slide is flush with front end of the upper swivel, therefore provides maximum tool support -- refer to figure 12.

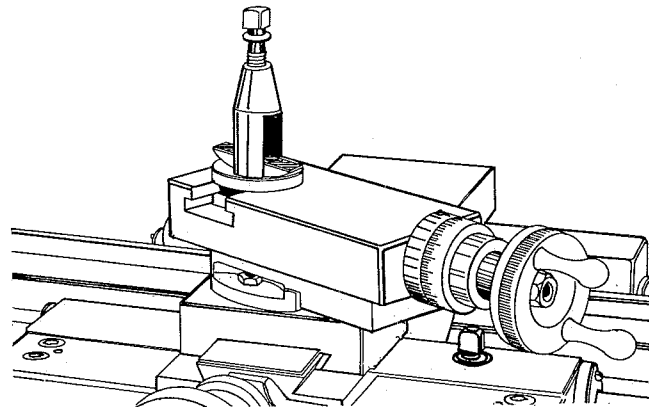

Figure 13

WRONG -- Unnecessary overhang of tool post slide will result in tool chatter, and could cause the tool post slide to break -- refer to figure 13.

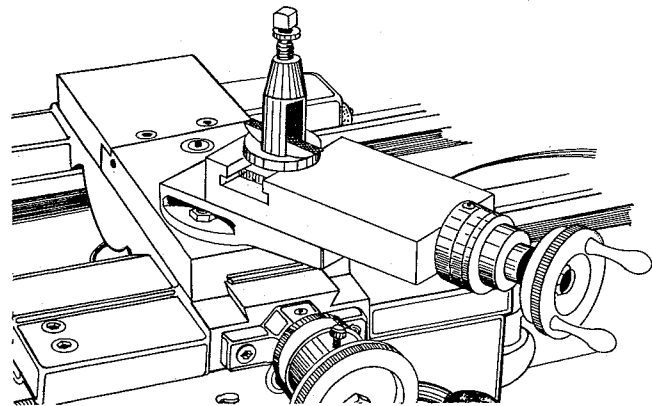

Figure 14

WRONG -- Tool post slide is too far back -- tool overhang is excessive -- refer to figure 14.

TAILSTOCK

The tailstock supports long work, and holds tools for drilling and reaming operations.

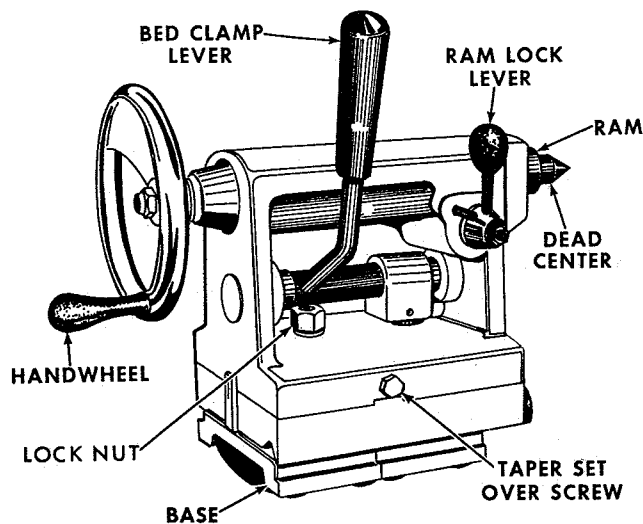

Figure 15

Base is fitted to bed ways to accurately align tailstock and headstock spindles, refer to figure 15. Tailstock slides along the ways, and may be anchored in any position by locking the bed clamp lever or tightening the auxiliary lock nut.

Ram is actuated by handwheel -- graduations simplify drilling and boring. Lever locks ram in position. Before inserting center or tools in ram, clean both tapers thoroughly with a clean, dry cloth.

Tailstock may be set over for taper turning by loosening the bed clamp and adjusting the screws on front and rear of tailstock base.

MOUNTING CHUCKS AND FACE PLATES

Before mounting on lathe, carefully clean the following:

1. Taper on spindle nose.
2. Threads in spindle nose collar.
3. Taper in chuck or face plate.
4. Threads on chuck or face plate.

Caution: Chips and dirt may score mating surface causing an inaccurate fit.

To mount face plate or chuck:

1. Rotate spindle until key is up.

2. Lock spindle by:

- (A) Placing back gear knob in engaged position.
- (B) Pushing handwheel pin in.

3. Lock chuck or face plate on spindle nose:

- (A) Slide chuck or face plate on spindle nose.
- (B) Tighten collar by turning spanner wrench counterclockwise.

4. Unlock spindle.

NEVER TURN ON POWER WHEN SPINDLE IS LOCKED.

TO REMOVE CHUCK OR FACE PLATE

1. Lock spindle.

- (A) Place back gear knob in engaged position.
- (B) Push handwheel pin in.

2. Place heavy board across bed to protect ways if chuck is dropped.

3. Loosen collar by turning spanner wrench clockwise.

4. *Carefully* remove chuck or face plate.

5. Unlock spindle.

NEVER TURN ON POWER WHEN SPINDLE IS LOCKED.

CHUCK MAINTENANCE AND CARE

PROTECT -- when not in use, place chuck in a covered box -- don't leave it exposed to dirt or chips -- the accuracy of any chuck can be destroyed if dirt or chips collect in the scroll, threads, jaws, or slots.

CLEAN and OIL FREQUENTLY -- Most wear is due to dirt and lack of proper lubrication. Oil chuck jaws and scroll at regular intervals with a light film of clean No. 10 S.A.E. machine oil. *Caution:* Do not apply too much oil -- it collects dust and chips.

IMPORTANT

KEEP YOUR LATHE CLEAN -- Oil and dirt form an abrasive compound which will damage bearing surfaces. Using way lubricant wipe the bed and all machined surfaces with a clean rag at frequent intervals. Use a brush to clean spindle, gear teeth, lead screw threads, etc.

MAINTENANCE AND ADJUSTMENTS

PREVENTIVE MAINTENANCE

The lathe should be kept clean and properly lubricated at all times.

Don't use your lathe for a work bench. Don't leave tools on bed ways.

Always shut off power before leaving lathe.

Recheck level of the bed frequently.

Lock tailstock to bed ways before turning between centers.

Before threading, clean chips and dirt from lead screw, and oil lightly.

Securely lock tool in position before taking a cut.

CLUTCH ADJUSTMENT

Adjusting clutch -- if the countershaft clutch slips when spindle drive is engaged, adjust as follows:

1. Remove front cover.

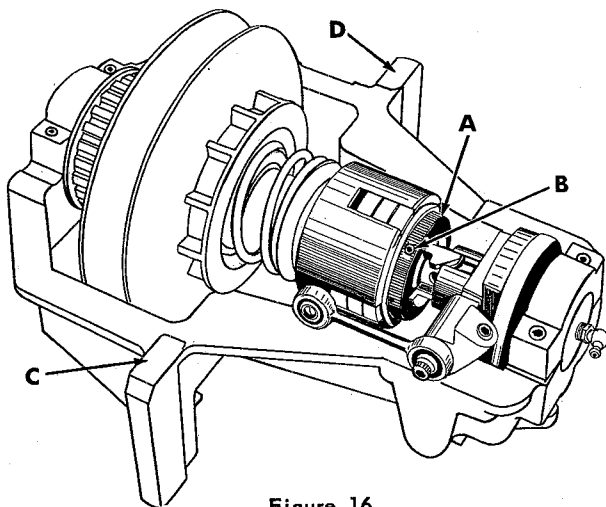

Figure 16

2. Loosen the lock screw (B, fig. 16) in the adjusting ring (A).
3. Turn the adjusting ring in a counterclockwise direction, when viewed from spindle pulley end. **DO NOT OVER-TIGHTEN** -- just enough to prevent slipping.

NOTE: If adjusting ring is turned too tightly -- clutch will not engage when clutch lever is moved up.

4. Retighten lock screw.

ADJUSTING CARRIAGE BEARING PLATES

Bearing plates on the carriage, which bear on the underside of both the front and rear bed ways, anchor the carriage firmly to the bed in a vertical direction. Bearing plates have shims of varying thickness for adjustment of possible wear.

CROSS SLIDE OR COMPOUND SLIDE GIB ADJUSTMENT

Gibs are properly adjusted, when tool post slide and cross slide move with a slight drag.

To adjust the tapered gibs:

1. Shift power feed lever to neutral position.
2. Loosen the rear adjusting screw several turns.

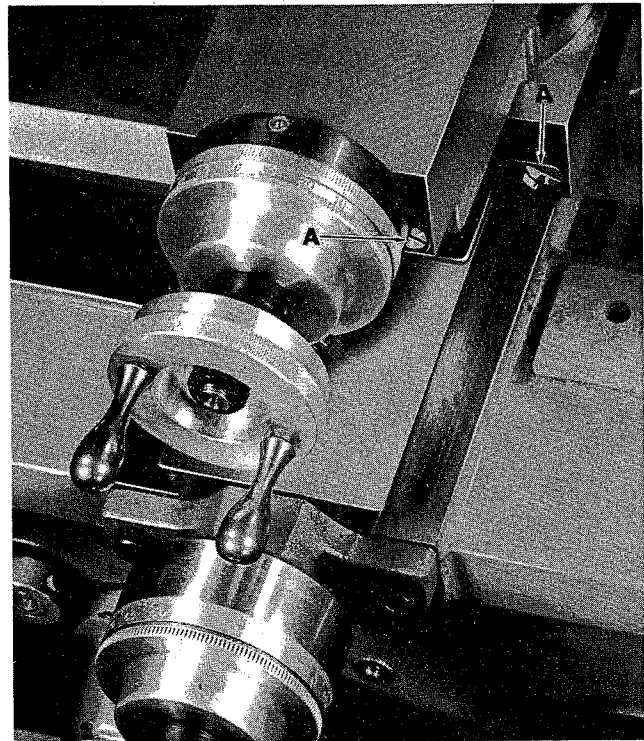

Figure 17

3. Turn front adjusting screw (A, fig. 17) until tight, then back off about one-half turn -- slide should move with a slight drag.
4. Retighten the rear adjusting screw.

TENSIONING TIMING BELT

1. Loosen slightly the four hex nuts holding the countershaft bracket to pedestal.
2. With a soft hammer, tap on bottom or top of countershaft bracket until belt is properly tensioned.

NOTE: Properly tensioned, timing belt should depress approximately $\frac{1}{2}$ " with light finger pressure -- too much tension causes excessive wear.

3. Measure to make sure that points (C & D, Fig. 16) on countershaft bracket are the same distance from top of head pedestal.
4. Tighten the four hex nuts securely.
5. Recheck belt tension.

REPLACING SHEAR PIN IN LEAD SCREW

Shear pin, located at gear box end of lead screw, protects lead screw and gear box against overload. To replace broken shear pin:

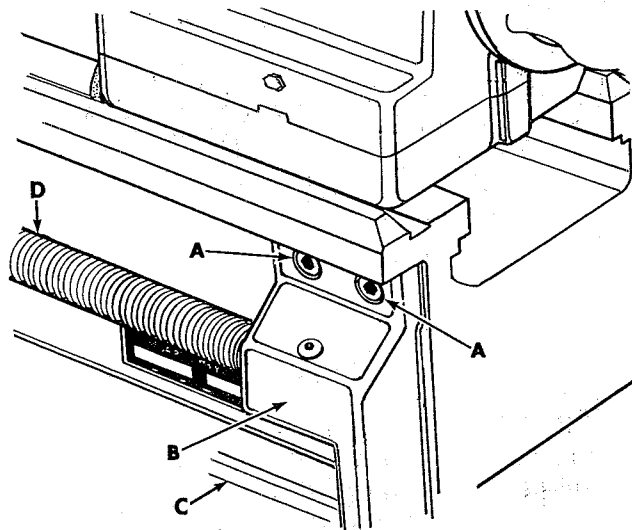

Figure 18

1. Remove two socket cap screws (A, fig. 18) from lead screw bracket (B). Remove bracket from lead screw (D) and clutch rod (C).
2. Engage half-nuts, turn carriage handwheel toward tailstock, pulling lead screw from gear box shaft. Disengage half-nuts and remove lead screw.

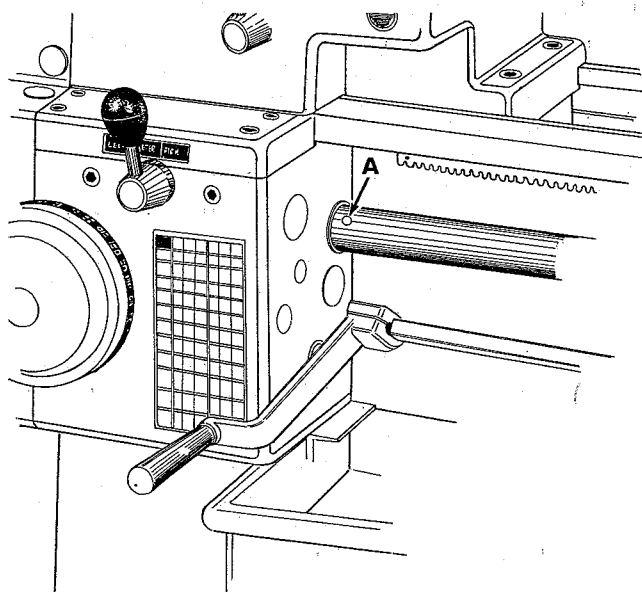

Figure 19

3. Remove sheared pin (A, fig. 19) from gear box shaft and lead screw.
4. Slide lead screw over gear box shaft -- check alignment of shear pin holes with punch -- turning lead screw 180° if necessary -- and install new shear pin.

5. Replace lead screw bracket -- CAUTION: Do not tighten the two socket cap screws.
6. Move carriage to tailstock end of bed, engage half-nuts to align lead screw and clutch rod, then tighten the two socket cap screws.

ADJUSTING SPINDLE BEARINGS

Spindle bearings have been preloaded at factory and seldom require adjusting. Follow these instructions should adjustment be necessary:

1. Make adjustment only when spindle is at operating temperature -- run spindle at medium speed for one hour with 8" driving plate mounted on spindle.
2. Disengage back gear pin from drive pulley by pulling pin away from headstock.
3. Turn back gear knob to the right.
4. Move lead screw direction knob to vertical (NEUTRAL) position.
5. Give driving plate a sharp spin with your hand.

NOTE: If preload is correct -- drive plate should rotate about one turn.

To adjust:

1. Remove spindle handwheel and upper belt guard.

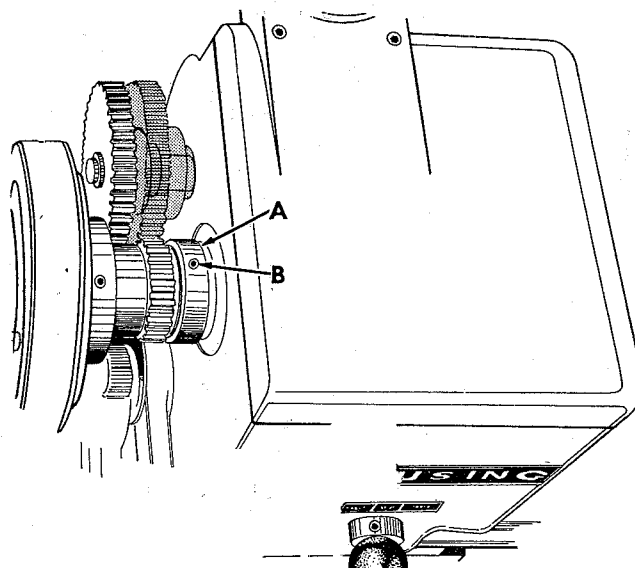

Figure 20

2. Loosen set screw (B) (fig. 20) in bearing adjusting nut (A) and tighten nut with spanner wrench until spindle end play has been removed.
3. Give driving plate a sharp spin with your hand -- drive plate should rotate about one turn. If it doesn't, adjust nut (A) and recheck.
4. Tighten set screw (B) in adjusting nut.
5. Replace guard and handwheel.

REPLACING VARIABLE SPEED BELT

1. With lathe running, turn variable dial to highest speed -- 1650 rpm in open belt or 230 rpm in back gear. Then turn off motor.

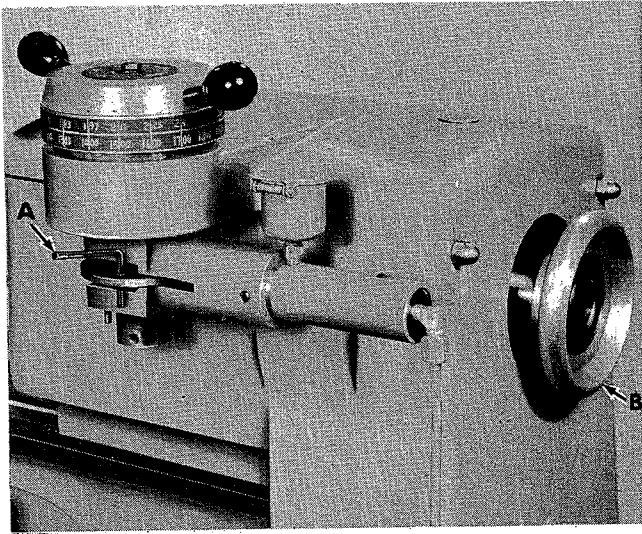

Figure 21

2. Remove spindle handwheel (B) (fig. 21), belt guards and front cover.
3. Turn variable dial back to lowest speed and lock dial in place with pin (A).

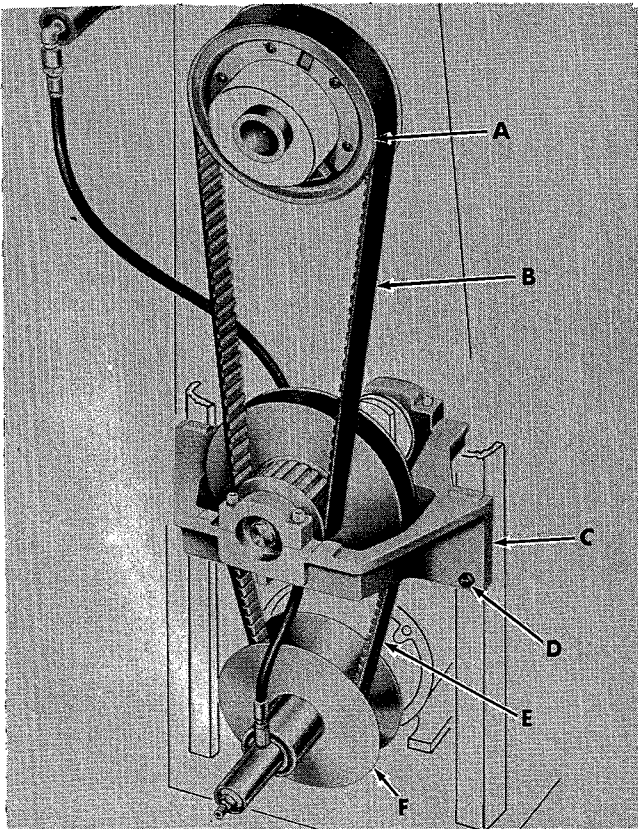

Figure 22

4. Holding variable dial against low speed stop, pull on outer sheave of lower variable motor pulley (F) (fig. 22) until variable belt (E) is loose.

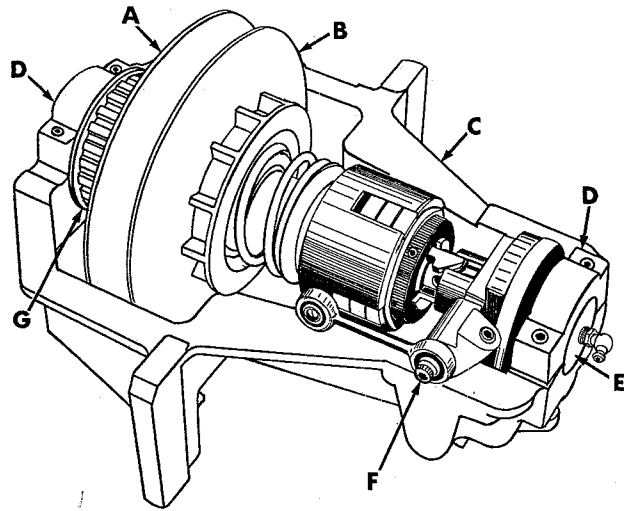

Figure 23

5. Thru front cover opening, remove 5/16"-18 hex cap screw (F) (fig. 23) and spacer from clutch linkage.
6. Remove four hex nuts (D) (fig. 22). Raise countershaft (C) slightly and slip timing belt (B) off spindle pulley (A). Lower countershaft and slip variable belt (E) off variable motor pulley (F).
7. Place countershaft on bench.
8. Remove bearing caps (D) (fig. 23), snap rings and countershaft spindle (E) from bracket (C).
9. Twist variable belt off countershaft pulley. CAUTION: Variable pulley is spring loaded and will snap closed when belt is removed.
10. Place new variable belt on countershaft pulley.
11. Install spindle in countershaft bracket and secure in place with snap rings and bearing caps (D). IMPORTANT: Make sure timing belt is in place before installing bearing caps.
12. Standing on countershaft bracket, pull variable belt into bottom of variable pulley sheaves (A & B).
13. Position the countershaft (C) (fig. 22) so variable belt (E) can be slipped on motor pulley (F), then raise countershaft so timing belt (B) can be slipped on spindle pulley (A).
14. Place countershaft assembly on the four mounting studs (D), then snug up the four hex nuts. Refer to Tensioning Timing Belt steps 2-5.
15. Thru front cover opening, install 5/16"-18 hex cap screw and spacer in clutch linkage.
16. Remove lock pin (A, fig. 21) from variable cam housing.
17. Start lathe motor.

18. Hold variable control against low speed stop for 30 seconds, then turn through entire range.
19. Check adjustment of variable drive belt -- refer to ADJUSTING VARIABLE DRIVE BELT.
20. Replace belt guards and front cover.

ADJUSTING VARIABLE DRIVE BELT

With motor on, turn variable control dial to HIGHEST SPEED -- use a tachometer to check spindle speed. If tachometer doesn't register approximately 1650 rpm:

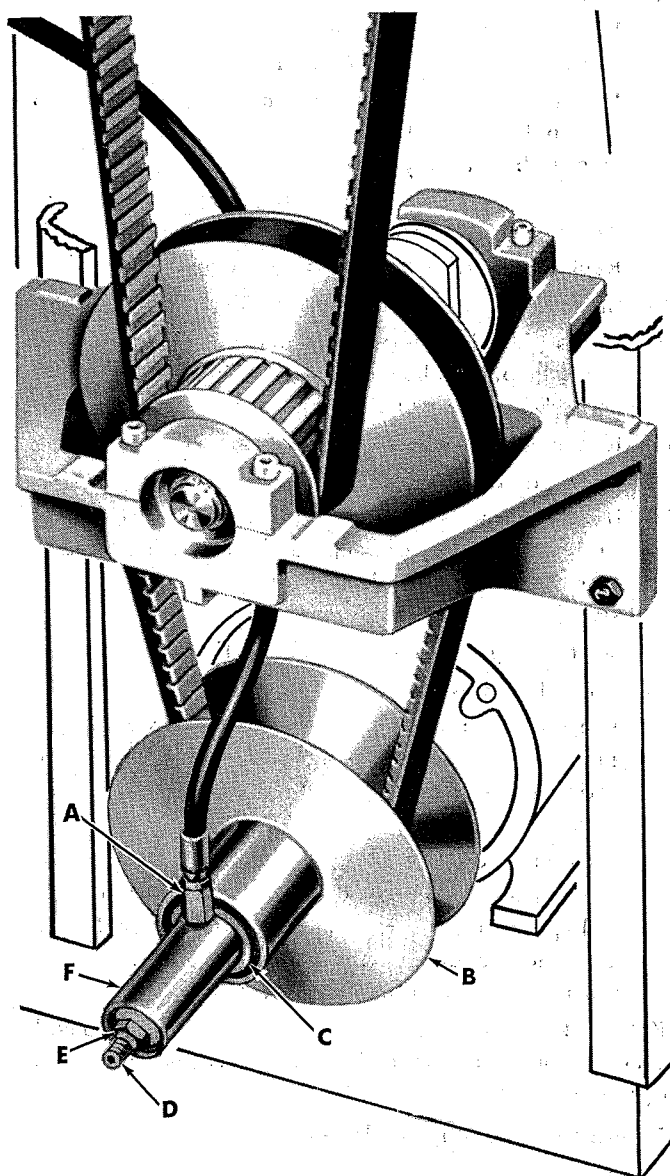

Figure 24

1. Hold nut (E, fig. 24) with wrench, and turn shaft (D) with a socket set screw wrench -- clockwise if speed is too low, counter-clockwise if speed is too high.

If tachometer is not available: Belt should be flush with out side of motor pulley at high speed and flush with outside of countershaft pulley at low speed.

Motor base brackets are bolted and doweled for permanent alignment.

REPLACING TIMING BELT

1. With lathe running, turn variable dial to highest speed -- 1650 rpm in open belt or 230 rpm in back gear. Then turn off motor.
2. Remove spindle handwheel (B) (fig. 21), belt guards and front cover.
3. Turn variable dial back to lowest speed and lock dial in place with pin (A).
4. Pull on outer sheave of lower variable motor pulley (F) (fig. 22) until variable belt (E) is loose.
5. Thru front cover opening, remove 5/16"-18 hex cap screw (F) (fig. 23) and spacer from clutch linkage.
6. Remove four hex nuts (D) (fig. 22). Raise countershaft (C) slightly and slip timing belt (B) off spindle pulley (A). Lower countershaft and slip variable belt (E) off variable motor pulley (F).
7. Place countershaft on bench.
8. Remove bearing caps (D) (fig. 23), snap rings and countershaft spindle (E) from bracket (C).
9. Remove timing belt from countershaft pulley (G).
10. Place new timing belt on countershaft pulley (G).
11. Install spindle in countershaft bracket and secure in place with snap rings and bearing caps (D). **IMPORTANT:** Make sure variable belt is in place before installing bearing caps.
12. Position the countershaft (C) (fig. 22) so variable belt (E) can be slipped on motor pulley (F), then raise countershaft so timing belt (B) can be slipped on spindle pulley (A).
13. Place countershaft assembly on the four mounting studs (D), then snug up the four hex nuts. Refer to Tensioning Spindle Belt steps 2-5.
14. Thru front cover opening, install 5/16"-18 hex cap screw and spacer in clutch linkage.
15. Remove lock pin (A, fig. 21) from variable cam housing.
16. Start lathe motor.
17. Hold variable control against low speed stop for 30 seconds, then turn through entire range.
18. Replace belt guards and front cover.

REPLACING UPPER VARIABLE CONTROL CYLINDER

1. With lathe running, turn variable speed dial to highest range (230 or 1650 rpm), then turn motor off.

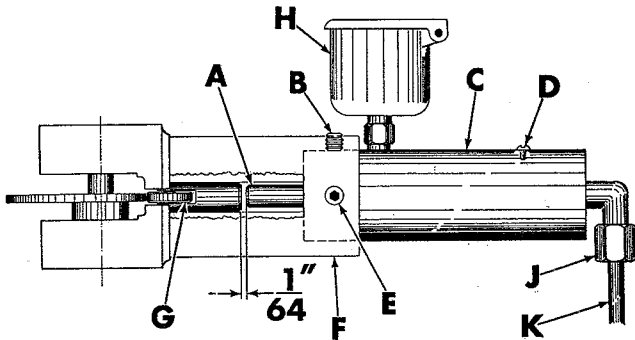

Figure 25

2. Remove nut (J, fig. 25) on end of variable control cylinder -- catching oil in pan.
3. Remove set screws (B) and (E) in variable cam housing (F).
4. Pull out upper variable control cylinder (C).
5. Remove the oil from old variable control cylinder oil reservoir (H).
6. While holding variable speed dial against low speed stop, slide new control cylinder (C) into variable housing (F) until variable plunger (A) is about 1/64" from cam roller plunger (G). Lock in place with set screws (B) and (E).
7. Install hydraulic line (K) and tighten nut (J).
8. Remove bleeder screw (D) and fill oil reservoir.
9. Keeping oil reservoir filled, hold variable dial against low speed stop until oil runs out bleeder hole -- it takes a few minutes for oil to run down.
10. Replace bleeder screw (D).
11. Start lathe motor. Hold variable control against low speed stop for 30 seconds -- turn variable dial to highest speed -- then back to lowest speed. Control should stay at 43 rpm.

NOTE: Watch dial for a few seconds. If it doesn't remain at 43 rpm, the hydraulic system must be bled to remove trapped air.

To remove air from hydraulic system:

- A. Run variable to highest speed.
- B. Loosen bleeder screw (D, fig. 25) a few turns until oil starts coming out around the screw.
- C. Retighten bleeder screw.
- D. Turn variable dial to low speed stop and release -- pointer should remain at 43 rpm.

NOTE: If dial moves, repeat steps A, B and C.

12. Permanently mark variable control cylinder location:

- A. Remove set screw (E).
- B. With a 1/4-inch drill, spot the cylinder for the 5/16" set screw (E).

NOTE: This drill mark simplifies future positioning of cylinder.

- C. Replace set screw (E).

REPLACING LOWER VARIABLE CONTROL CYLINDER

1. With lathe running, turn variable speed dial to highest range (230 or 1650). Then, turn motor off.
2. Measure distance from end of shaft (D, fig. 24) to nut (E). NOTE: *Record this dimension.*
3. Disconnect fitting (A) and drain oil from unit.
4. While holding shaft (D) with a socket set screw wrench, remove nut (E) and washer.
5. Remove, sleeve from hydraulic cylinder.
6. Pull hydraulic cylinder (F) and outer half of variable pulley (B) off the shaft (D) and remove stop washer from pulley (B).
7. Press hydraulic cylinder (F) with bearing (C) from variable pulley (B).
8. Replace the two "O" rings on shaft (D).
9. Install stop washer in pulley (B).
10. Press new hydraulic cylinder with bearing into variable pulley hub (B), then slide the assembly onto shaft (D) and pulley hub.
11. Install sleeve and washer on shaft (D).
12. Start nut (E) on shaft (D).
13. Hold the shaft in place with a socket set screw wrench and then turn nut onto rod until distance from the end shaft (D) to nut (E) is the same as step 3.
14. Start fitting (A) onto hydraulic cylinder (F).
15. Fill oil reservoir.
16. Keep oil reservoir filled, hold variable dial against low speed stop until oil runs out around fitting (A) -- it takes a few minutes for oil to run down.
17. Tighten fitting (A).
18. Start lathe motor. Hold variable control against low speed stop for 30 seconds -- turn variable dial to highest speed -- then back to lowest speed a few times. Control should stay at 43 rpm.

NOTE: Watch dial for a few seconds. If it doesn't remain at 43 rpm, the hydraulic system must be bled to remove trapped air.

To remove air from hydraulic system:

- A. Run variable to highest speed.
- B. Loosen bleeder screw (D, fig. 25) a few turns until oil starts coming out around the screw.
- C. Retighten bleeder screw.
- D. Turn variable dial to low speed, stop and release -- pointer should remain at 43 rpm.

NOTE: If dial moves, repeat steps A, B, and C.