

***SP2000 and SP2500
Super Precision
Drill Sharpener
Operator's Guide***

DAREX

DAREX

Manufactured and serviced by
the Darex Corporation
220 Hersey St. / Box 277 Ashland OR 97520
1-800-547-0222

REV. 6/98

US DEPARTMENT OF LABOR

Form Approved OMB No.44-R1367

Occupational Safety and Health Administration
MATERIAL SAFETY DATA SHEET

Required under USDL Safety and Health Regulations for Ship Repairing,
Shipbuilding and Shipbreaking (29 CFR 1915, 1916, 1917)

SECTION I

MANUFACTURER'S NAME EMERGENCY PHONE NO.
Darex Corporation (503) 488-2224

ADDRESS (Number, Street, City, ST, Zip Code)

220 Hersey Street, Ashland, Oregon 97520

CHEMICAL NAME & SYNONYMS TRADE NAME & SYNONYMS
Diazon-Electroplated Diamond/CBN Products Electroplated Diamond Wheels
Diamond (uncoated), Man-Made * Diamond, Electroplated CBN Wheel
RVG, MBG, MBS Product Families, Standard Series and 300 Series Diamond Micron Powder

CHEMICAL FAMILY FORMULA

Abrasive/Any Grade N/A

SECTION II - HAZARDOUS INGREDIENTS

PAINTS, PRESERVATIVES, & SOLVENTS %	TLV (UNITS)	TLV (UNITS)
PIGMENTS	-----	-----
CATALYST	-----	-----
VEHICLE	-----	-----
SOLVENTS	-----	-----
ADDITIVES	-----	-----
OTHERS	-----	-----
	-----	-----
	-----	-----
	-----	-----
	-----	-----
	-----	-----
	-----	-----

HAZARDOUS MIXTURES OF OTHER LIQUIDS, SOLIDS OR GASES TLV
(UNITS)

NAIF

SECTION III - PHYSICAL DATA

BOILING POINT (F)	NAIF	SPECIFIC GRAVITY (H ₂ O = 1)	NAIF
VAPOR PRESSURE			
VAPOR DENSITY (AIR = 1)	NAIF	PERCENT VOLATILE BY VOLUME (%)	NAIF
SOLUBILITY IN WATER	NAIF	EVAPORATION RATE =1	NAIF
APPEARANCE AND ODOR	CLEAR, WHITE TO YELLOW TO DARK CRYSTALS SILVER COLOR		

SECTION IV - FIRE AND EXPLOSION HAZARD DATA

FLASH POINT (METHOD USED)	FLAMMABLE LIMITS	LEL	UEL
NAIF		---	---

INGESTION NAIF

SKIN PROLONGED CONTACT WITH NICKEL
MAY CAUSE DERMATITIS
MORE FREQUENTLY AT HIGH
TEMPERATURE & HUMIDITY

WASH SKIN WITH
WATER. SEEK
MEDICAL ATTENTION
IF NEEDED

EYES DUST MAY IRRITATE EYES

WASH WITH LARGE
AMOUNTS OF WATER
SEEK MEDICAL
ATTENTION IF NEEDED

OTHERS GRINDING MAY CREATE ELEVATED
NOISE LEVELS WHICH MAY EFFECT
HEARING

EMERGENCY AND FIRST AID PROCEDURES
OBTAIN MEDICAL ASSISTANCE

SECTION VI - REACTIVITY DATA

STABILITY	UNSTABLE	CONDITIONS TO AVOID
		STABLE X

INCOMPATIBILITY (Materials to avoid)
NAIF

HAZARDOUS COMPOSITIONS PRODUCTS
NAIF

HAZARDOUS POLYMERIZATION
WILL NOT OCCUR

CONDITIONS TO BE AVOIDED
CONTACT WITH STRONG ACIDS/CAUSTICS

SECTION VII - SPILL OR LEAK PROCEDURES

STEPS TO BE TAKEN IN CASE MATERIAL IS RELEASED OR SPILLED
Normal clean up procedure

WASTE DISPOSAL METHOD
Standard landfill methods

SECTION VIII - SPECIAL PROTECTION INFORMATION

RESPIRATORY PROTECTION (Specify type)
Respiratory protection as needed see OSHA 29 CFR 1910.134

VENTILATION	LOCAL EXHAUST	SPECIAL
	Recommended see OSHA 29 CFR 1910.94	

FLASH POINT (METHOD USED) NAIF	FLAMMABLE LIMITS LEL UEL	---	---
EXTINGUISHING MEDIA WATER			
SPECIAL FIRE FIGHTING PROCEDURES NONE			
UNUSUAL FIRE AND EXPLOSION HAZARDS NONE			

SECTION V - HEALTH HAZARD DATA

EFFECTS OF OVEREXPOSURE

INHALATION IF DUST GENERATED, IT COULD CONTAIN NICKEL, INHALING CAN CAUSE RESPIRATORY DISEASE. DUST CAN RESULT FROM GRINDING

OBTAIN MEDICAL ATTENTION

VENTILATION	LOCAL EXHAUST	SPECIAL
	Recommended see OSHA 29 CFR 1910.94	
PROTECTIVE GLOVES	EYE PROTECTION	
As desired by user	Recommended see OSHA 29 CFR 11910.215	
OTHER PROTECTIVE EQUIPMENT NAIF		
SECTION IX - SPECIAL PRECAUTIONS		
PRECAUTIONS TO BE TAKEN IN HANDLING AND STORING NAIF		
OTHER PRECAUTIONS NONE		

Basic information on your Darex Super Precision Drill Sharpener

SP2000 creates helical S-points. These high-tech points give the strength of a standard point plus excellent hole geometry. The S-shaped crown contour makes the point self-centering.

SP2500 Drills sharpened on your SP2500 may appear to have less drill relief than ordinary drills. The split point geometry may also look slightly different from ordinary drills. However, this superior SP2500 drill point will cut tighter tolerance, more on-size holes.

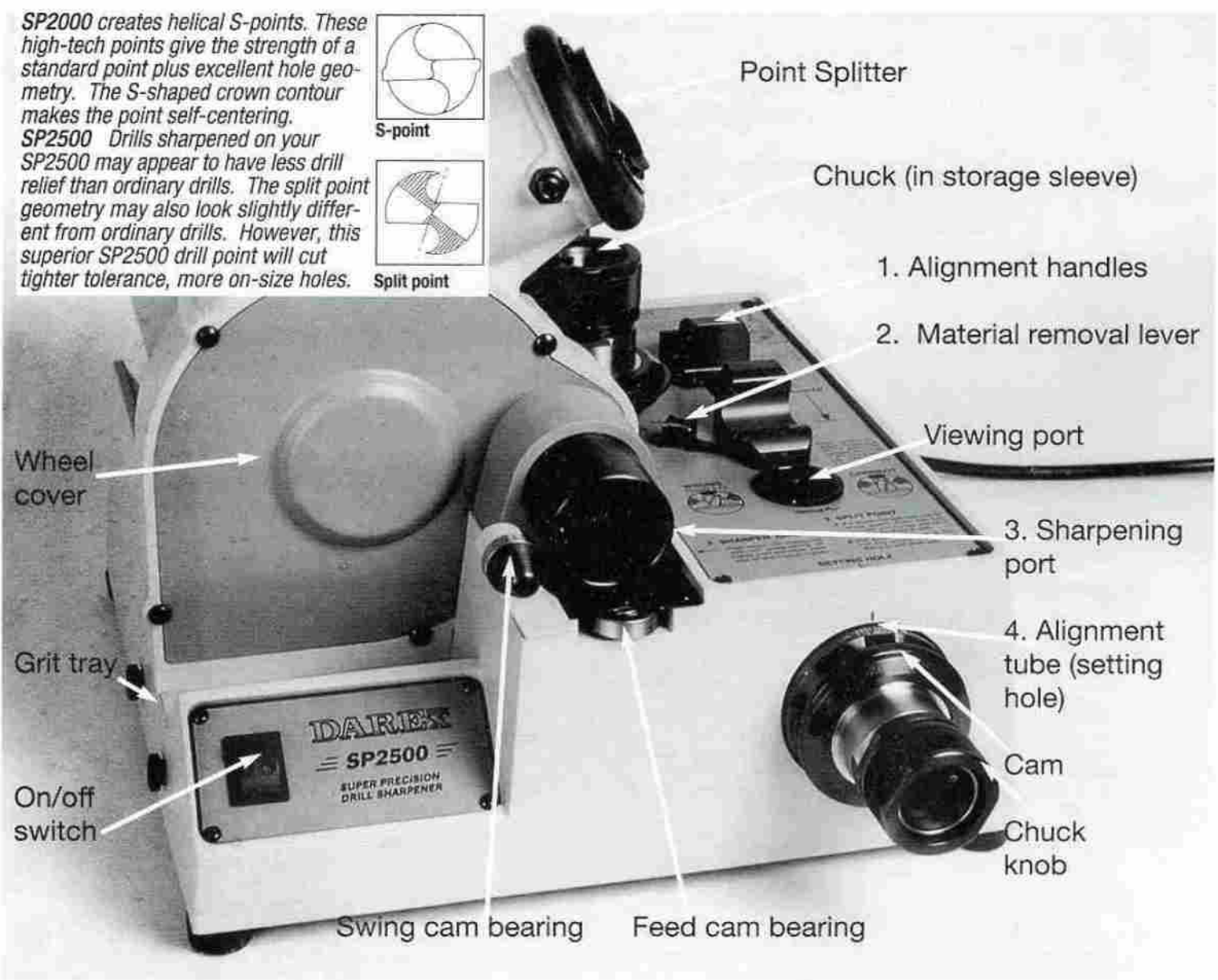
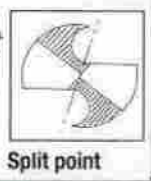
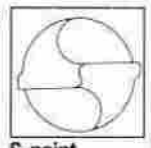

The Basic Concept of your Darex Super Precision Drill Sharpener

Your Super Precision Drill Sharpener makes makes drill sharpening easy. The basic steps in sharpening a drill include: Aligning or setting the drill,

Sharpening the drill,

Splitting the point , (if you have an SP2500).

Here are some of the innovative features and concepts that went into the design of your new Super Precision Drill Sharpener:

1. **Alignment handles** control the pawls that grip the drill by the flutes and properly position the drill. By tightening the chuck knobs the drill is held firmly in place for all sharpening procedures.

2. **Material removal take off lever:** This allows you to control the amount of material to be removed from the drill point.

3. **The sharpening port:** By rotating the chuck in the sharpening port the drill is sharpened by a beveled super abrasive grinding wheel.

4. **Alignment tube:** Here the chuck and drill are aligned. This step is essential to produce a proper drill grind.

The precision chucks: All three chucks are adjustable to fit your drill by turning of the chuck knobs (size range of each chuck is marked on the cam) Specific parts of the chuck include:

1. **Chuck knob:** By rotating the chuck knob, the jaws are opened and closed to accommodate drill size variation.
2. **Cams:** Threaded on to the chuck, the cams produce the proper drill point grind needed to drill a correct hole.
3. **Cam dogs:** The tabs on front of the cams.
4. **Jaws:** Hold the drill in place.

1. Chuck knob
2. Cam
3. Cam Dog
4. Jaws



INSTRUCTIONS FOR SHARPENING DRILLS WITH YOUR NEW DAREX SUPER PRECISION DRILL SHARPENER

You'll notice the basic instructions are printed on top the machine for your convenience. These more detailed instructions will better help to familiarize you with your SP Super Precision Drill Sharpener.

Aligning (or setting) the drill (steps 1-8)

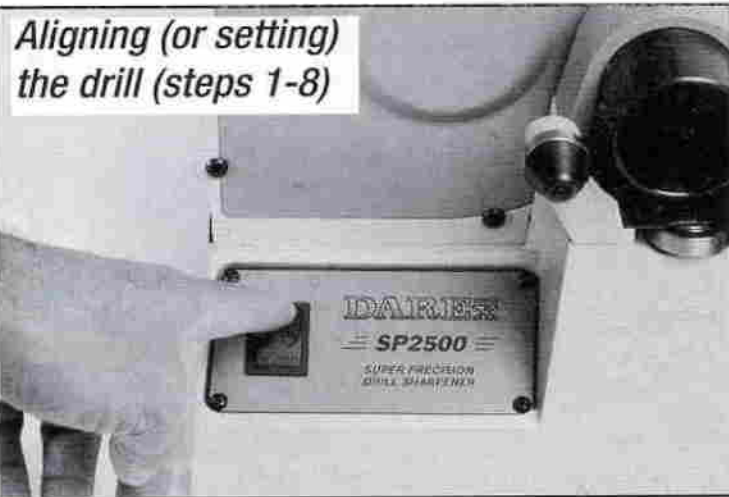

1. Flip the red rocker switch. This turns the machine's motor on. This also illuminates the viewing port.

2. Insert the drill into the appropriate sized chuck (sizes are on cam). Rotate the chuck knob which opens and closes the chuck jaws onto the drill. Then slightly loosen the chuck jaws. To determine how tightly drill should be held, remember: The drill should slide out when the chuck is held in a vertical position.

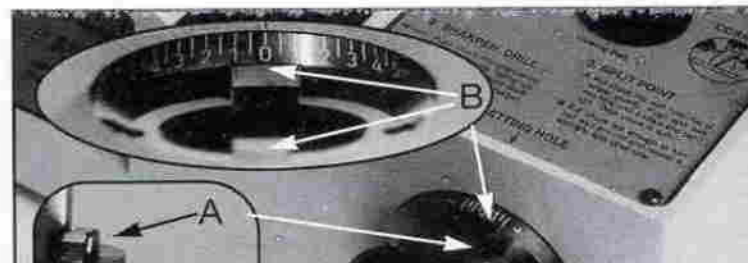
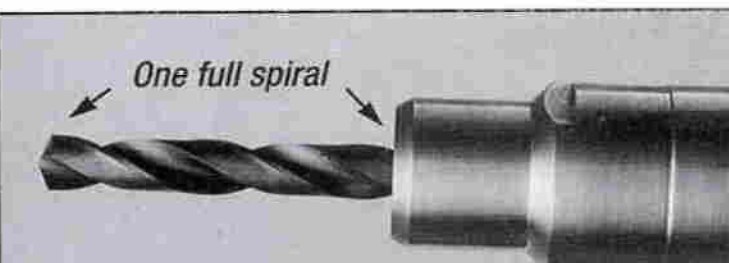



3. Hold the chuck in a horizontal position. Allow the drill to protrude at least one full spiral as shown. A full spiral is one full rotation of a "land". The land is the raised spiral edge around a drill.

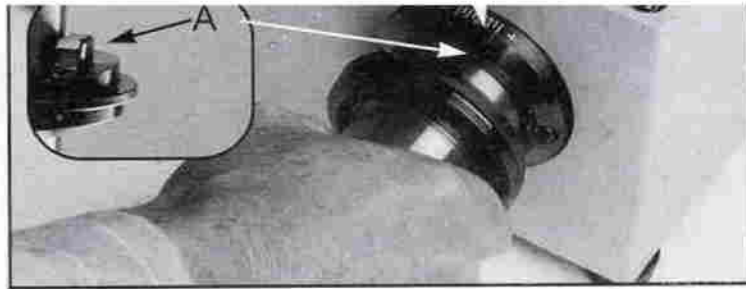

4. Insert the chuck with the drill into the alignment tube. The cam dogs (A) should bottom out against the alignment slots (B).

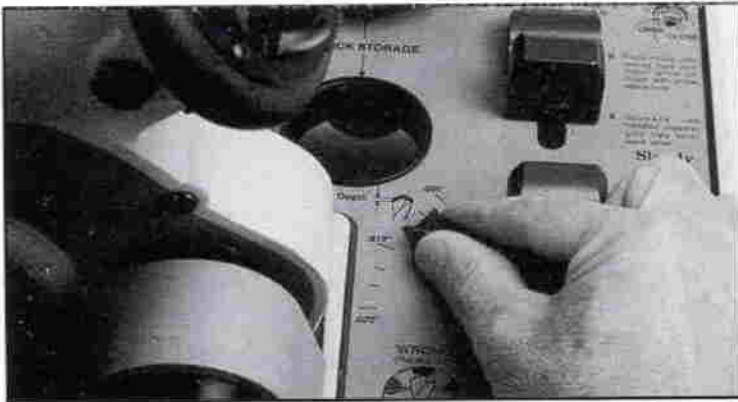

5. Set the material removal lever to the amount you want to remove from the drill. Remove more material if the drill is excessively worn or damaged. Remove less drill point material if you are renewing the drill. Hint: Your drills will last longer if you sharpen them more often and remove less material; you will be able to drill faster too.

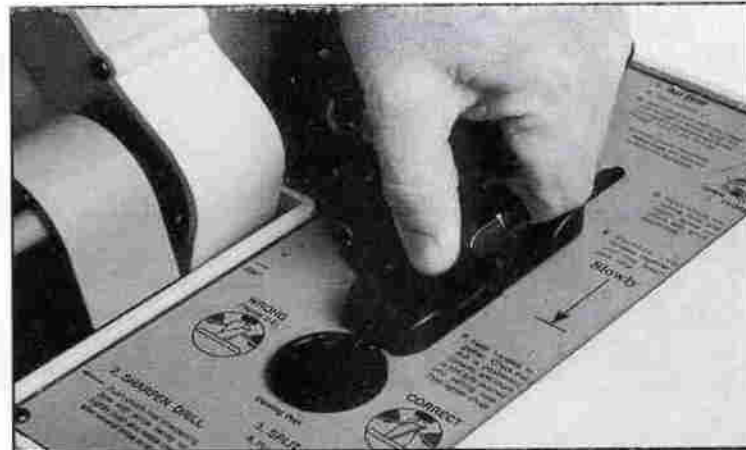

6. S-L-O-W-L-Y squeeze the red handles together until they touch. We emphasize slowly because squeezing the handles too quickly pushes the drill too deeply into the chuck. While holding handles together, make sure cam dogs are seated in alignment slots.

3

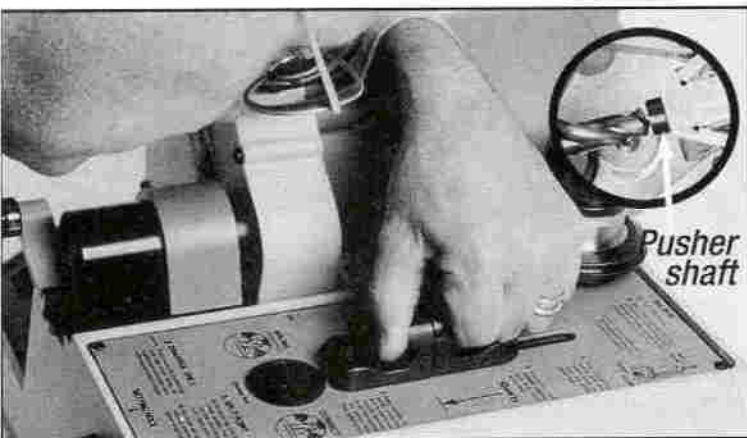

7. With the red handles held together, look through the viewing port and see if drill is positioned correctly. Drill point should be in contact with pusher shaft (see inset above). Are the pawls holding the drill by the flutes properly? Then tighten the chuck knob. Please notice the diagrams on either side of the view port marked wrong and correct. For short drills, rotate the chuck, enabling the pawls to grip the flutes.



8. Tighten the chuck onto the drill by turning the knurled handle in a clockwise direction. Release red handles and remove chuck.

Sharpening the drill



Splitting the point



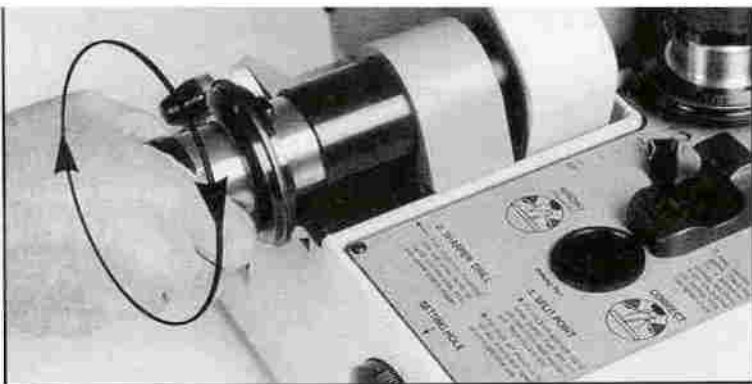

9. With cam dog in the upper most position, insert the chuck into sharpening port. Rotate the chuck 360 degrees several times in a clockwise direction with a slight pressure towards the grinding wheel. To achieve an efficient and balanced sharpening of both cutting edges it is advisable avoid starting or stopping at mid-sharpening. When the grinding sound is minimized to a near silence the sharpening process is complete.



10. (Point splitting is applicable only to the SP 2500). Upon completion of the sharpening procedure insert the chuck with the drill into the point splitting port. The cam dogs will align and fall into slots. Pivot the chuck knob upwards for several seconds then release. Be sure chuck stays seated in the point splitter. To split opposite side of the drill point, pull chuck partially out and rotate it 180 degrees. Repeat procedure.



Emptying the grit tray

Grit Tray. As you use your sharpener drill grindings will accumulate inside the grit tray. For best results do not let tray become more than one third full. The grit tray has magnetic liner to attract and hold these drill particles. To remove tray unscrew thumb screws. Remove tray and dump contents. Wipe away excess drill grindings in the tray with a rag.

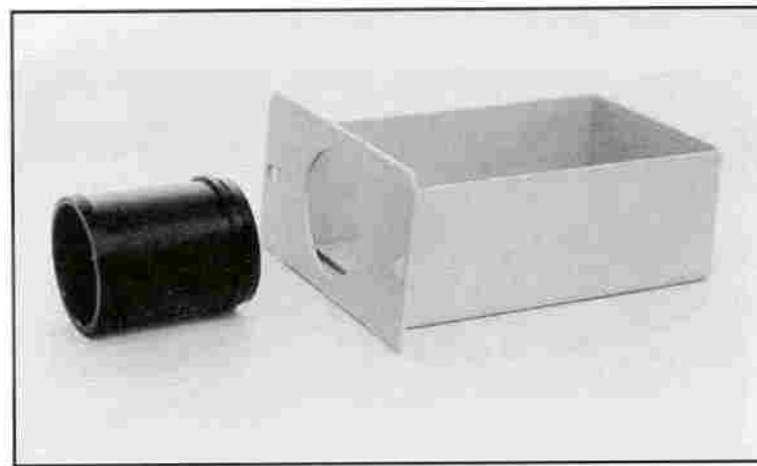

Grit tray vacuum tube: The grit tray has a hole plug in the front. If you wish to attach a vacuum system to your sharpener, a grit tray exhaust connector is packaged with the machine. This method of extracting particles from the machine will keep it cleaner.
Installing tube: Snap existing plug out of tray, then push tube in firmly until it snaps solidly into the hole.

4



Changing the wheels

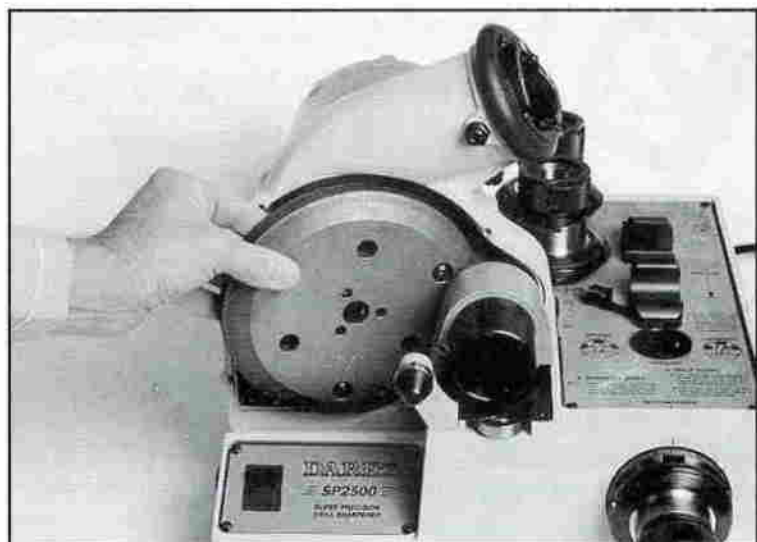



1a. Eventually, the long-life electro-plated wheel in your SP will wear out. Indicators that a wheel change is necessary are a drop in performance such as drill burning and excessively slow sharpening time. To change the wheel **UNPLUG** the machine. Remove the four screws holding the grinding wheel cover plate. Slide the plate to the left and out from behind the spring loaded sharpening port tube. (To facilitate the removal of the cover plate, remove grit tray and push the cover plate off from the backside)



3a. Inspect the wheel for abrasive quality. A worn wheel will appear smooth at the outer edge. Remove the sharpening wheel from the split point wheel (applicable only to SP 2500). The split point wheels life may be doubled by simply turning it around. If necessary, replace the worn wheel(s). Note: New wheels for will initially produce a coarser grind. However, this aggressiveness will disappear after the first one hundred drill sharpenings. You should experience many thousands of drill sharpenings from each new wheel.

Note:

The standard wheels on this machine are CBN (Borazon) for grinding high speed steel or cobalt drills. **Important:** Do not attempt to grind carbide drills with CBN wheels. Diamond wheels are available if carbide drills are to be sharpened on this machine. NO dressing or cleaning of these wheels is necessary.



2a. To remove the wheel, unscrew the three screws located in the center area of the wheel. Pull the wheel toward you and to your left.



4a. Place wheels back onto the hub, making sure to clean wheel and hub of any dirt. Be sure wheel sets flat on hub, gradually tighten the screws. Move from screw to screw in an alternating pattern. Tighten each screw a quarter turn until all screws are completely tight. **IMPORTANT:** After tightening the screws-rotate wheel by hand to check that wheel runs true. If not, loosen the screws, reposition wheel and tighten screws as mentioned previously. Replace cover; you will need to push the spring loaded sharpening port tube back with a thin bladed screw driver or knife, as shown.

Do not use any type of dressing tool on these wheels. Damage to surface will occur and greatly shorten wheel life.

For wheel replacement contact your local dealer or Darex Corporation 1-800-547-0222.



Answers to questions you may have about your Super Precision Drill Sharpener

I aligned the drill and put it into the sharpener, but no

Can I change the cams? Yes. The cam unscrews and slips off the front of chuck. (See "Chuck Maintenance", page 10) Replacement cams are available from the manufacturer.

I sharpened a drill, why doesn't it drill properly? If

I aligned the drill and put it into the sharpener, but no material gets removed, why? You may have allowed the alignment pusher bar to knock the drill too far back into the chuck. Remember to close the red handles slowly. See steps 6 and 7 on pages 3 and 4.

The drill was properly aligned, but I'm still not getting the proper geometry, why? If the drill has a different helical or twist, changing the alignment tube setting plus or minus may be necessary. For example, cobalt or parabolic drills need to have an alignment setting of one to 1 1/2 lines to the minus setting. Also if you have a drill with a wider than normal flute use that setting. Changing this setting can effect the relief, chisel line and point split results. See page 7.

What is the appropriate setting for the grind depth lever? Use the most minimal setting to sharpen your drill. The less material removed to sharpen the drill, the longer the drill life. If drills are run until they are very dull, then more material must be removed to resharpen them. Also a sharper drill makes a better hole.

What types of drills can I sharpen with my SP? Your sharpener is equipped with CBN grinding wheel (or wheels) as standard equipment unless you specified diamond wheel (or wheels). The CBN wheels are recommended for HSS and cobalt drills. DO NOT SHARPEN CARBIDE DRILLS WITH A CBN WHEEL! Diamond wheels are the only wheels recommended for carbide drills. PROLONGED SHARPENING OF HSS DRILLS WITH A DIAMOND WHEEL WILL EVENTUALLY CHANGE THE WHEEL RENDERING IT TOO SMOOTH FOR GRINDING!

When do I change the grinding wheel? The grinding wheel supplied with the SP super precision drill sharpener is designed to give you long and trouble-free service. Eventually, you will need to replace the wheel. Drill burning and an increase in drill sharpening time are indicators that the wheel needs replacement. See page 5.

How do I change the relief of the drill? The relief is adjusted by use of the relief adjustment alignment tube located on the front of the sharpener. Loosen the Allen screw and rotate the relief adjustment in the desired direction. Positive (+) gives you more relief, which is recommended for drilling softer materials. Less (-) relief is recommended for drilling harder materials. If the setting fixture does not easily turn by hand, insert a chuck into the fixture. Hold the chuck by the cam and body and rotate the fixture.

I sharpened a drill, why doesn't it drill properly? If you are getting oversized holes, set the alignment tube one or two lines to the minus setting. If relief is not adequate adjust alignment tube to the plus setting a line or two. See pages 3, 4, and 7.

What do I do if the drill point is off center? Possible causes include debris in chuck or on drill. An air hose will clean metal chips out of chuck or off of drill. For a more thorough cleaning disassemble chuck. See page 10.

Why don't my drills align correctly, like the "right" diagram on SP instruction panel? There may be a burr on the drill shank. The drill is not one full spiral out of chuck. The drill is too loose or too tight in chuck.

I am not able to split the point completely. Why? The SP 2500 split point rubber boot may be jammed with metal particles. Squeeze boot with finger tips to dislodge collected particles. Particles will fall into metal particle collection tray. Another possibility is the depth adjustment screw may have moved. To adjust this screw see page 9.

How do I change the point split wheel? This pertains only to the SP 2500. See page 5.

Can I produce "S" points on the 2500? Yes, to generate a true helical "S" drill point, you may acquire the SP 2000 cams to install on your existing chucks. Some adjustment of the swing cam bearing will be needed. (See page 8)

How do I change the light bulb? The light bulb is accessed by removing the bottom electrical cover. Undo the screws in each corner to remove cover. Use a 120 volt 15 watt bulb.

What routine maintenance procedures do I need to follow? Chuck maintenance is very important (see page 10). To maintain the sharpener itself, first remove grit tray and empty. Tip machine so you can access the bottom electrical cover. With a dry paint brush remove any grindings or filings that may have accumulated on the pusher shaft, pusher bar and any parts that could be affected by these particles. Swab sharpening port and point split port occasionally with a dry cloth. (Never use an oil-base lubricant on any part of this machine! Oil-base lubricant will collect particles.) Powdered graphite may be applied to any sliding parts located under the machine.

Alignment Instructions

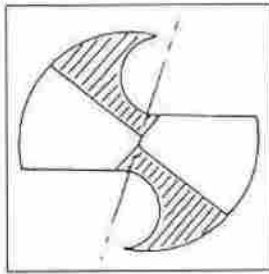

SP 2500 Split Point Drill

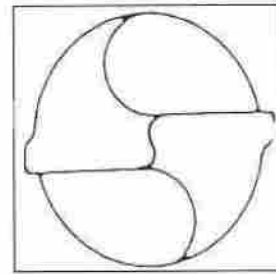

SP 2000 Helical "S" Point Drill

Your SP2000 or SP2500 machine is carefully adjusted at the factory. However, if for some reason the drill sharpener is not set to sharpen your particular drill, the following should assist you to acquire a correct drill point. Also, if you are using cobalt, parabolic, or other specialty drill, the unit can usually be adjusted to sharpen these types of points.

Hole size: If your holes are over-size after grinding a drill point, then set the alignment tube a line or so to the minus setting. This will result in less relief and closer hole size. Also, under certain drilling conditions, not splitting the drill may produce more on-size holes.



High Helix



Low Helix

Depending on helix of your drill (see illustration), you may need to set the chuck alignment tube to a different setting. For low helix drills, set the alignment tube to a (+) location. The high helix drills require a setting to the (-) location. Several experimental grinds may be needed to achieve the correct point for these types of drills. **Cobalt or parabolic;** these drills have a thick web and require a setting of one or two lines to the minus setting of your alignment tube. Also, drills that have wider flutes in relation to the land and margin may require a minus one or two line setting of the alignment tube.

Small Drills: Small drills around 1/8" might have too much relief and excessive chisel angle which makes a flat appearing point. Set the alignment on approximately a one line minus setting to get the proper grind.

Adjustments to increase or decrease relief angle: Adjustments are made by rotating the alignment tube (see Alignment tube below) Loosen Allen screws in front of tube and rotate to desired setting, then tighten screws. If it is difficult to turn, put the chuck into the tube and rotate the chuck with the dogs engaged.

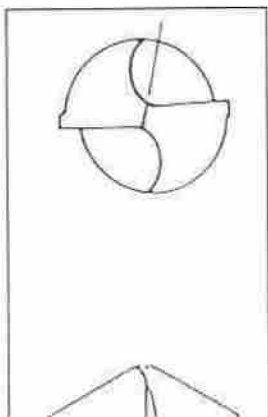

Alignment tube
Chuck Timing Tube (Top view)

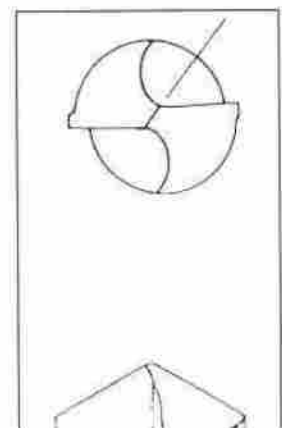

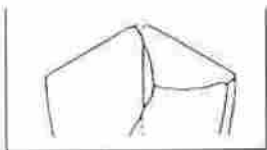

Minus (-) setting
(less relief, turn clockwise)



Plus (+) setting
(more relief, turn counter-clockwise)

SP 2000 Helical Adjustment

Helical or point at chisel edge (see fig. 2)

Fig. 2 To adjust for a more (or less) helical point on your drills, The following adjustment on swing cam follower can be made. (see fig. 3)

A. Mark or scribe line on cone top and post top for reference.

B. Insert Allen head wrench, loosen cone & rotate clockwise, (CW), about 1/32" to increase the helical somewhat.

C. When turning cone CW - the chisel edge on drill will move in a CCW direction and helical will protrude more (see fig. 4).

Note: This adjustment, combined with the alignment tube adjustment will cover most drill point requirements.



Fig. 2

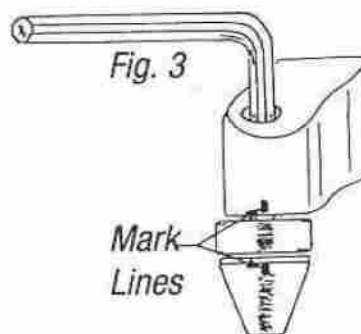

Fig. 3

Mark
Lines

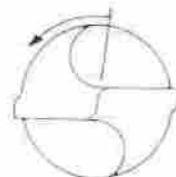

Fig. 4

SP2000 and SP2500 Material Removal Adjustment:

If the amount removed from the drill is not the same as the setting on the "Material Removal Lever", then adjust the following: Notice at the rear of the machine base there is a small plastic plug. Remove this plug.

Insert a (3/16") Allen wrench into the hole, making sure that it goes into the Allen head screw inside the hole. To set the adjustment to remove **less** material off the end of the drill, rotate the wrench clockwise, until you reach the adjustment you need. Each 1/4 turn will adjust .010" (.25mm) or one full turn will adjust .040"



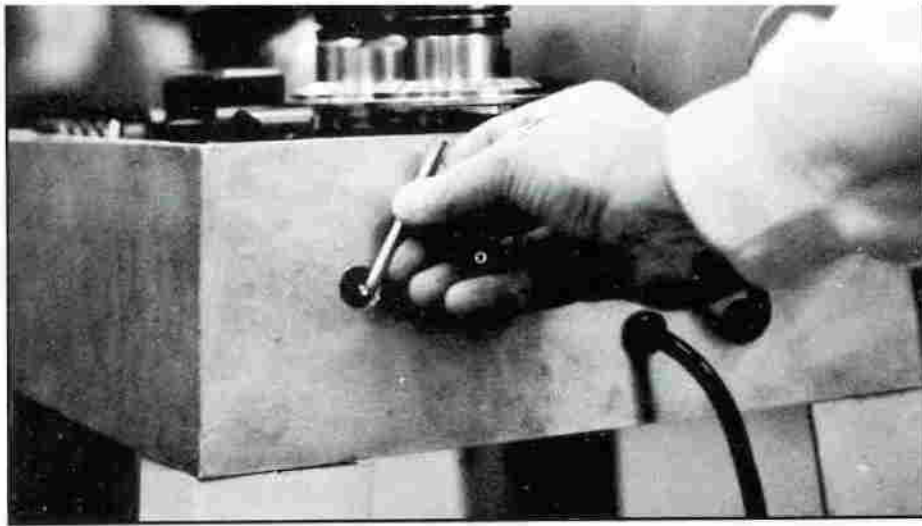

you need. Each 1/8 turn will adjust .001" (.25mm) or one full turn will adjust .040" (1.0mm). Use a depth gauge to measure the drill tip after alignment, then grind the drill. Measure the drill again and determine if difference coincides with the material removal lever setting.

8

SP2500 Adjustment Instructions

Darex SP 2500 point splitter pivot tube adjustment

To make adjustments on the point splitter, use a drill approximately 5/8" to 3/4" size. Sharpen the drill and split the point. Then inspect the split. If the split is not all the way to the chisel line on the drill point, (see fig. 7) loosen the lock nuts on the pivot screws located on each side of the point splitter, (see fig.9). Loosen the front screw about 1/8th of a turn and then tighten the rear screw. Now, split the drill again to see if the adjustment is satisfactory. If the drill is over split, (see fig. 8) loosen the rear screw and tighten the front screw. Be sure to tighten the lock nuts upon the final adjustment.

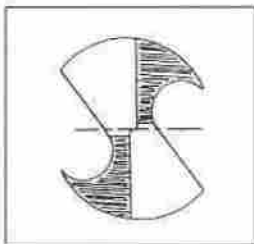

Fig. 7 Under split

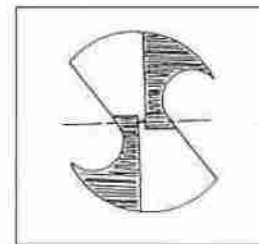
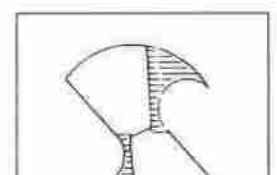
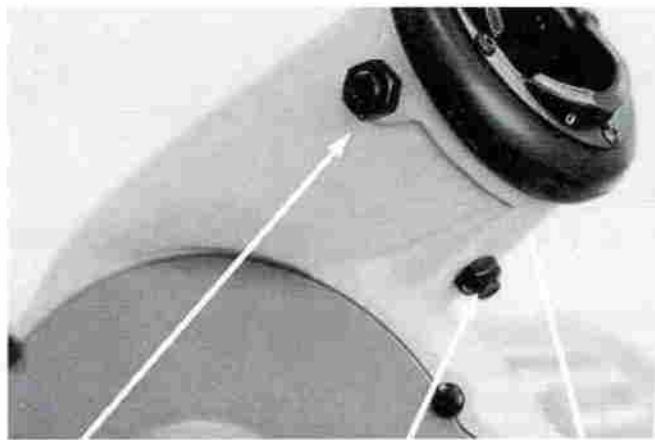

Fig. 8 Over split

Depth of split: The depth adjustment screw is located directly under the point splitter pivot tube, (see fig. 9) To adjust the point split - loosen the depth adjusting screw locknut. If the drill is not split enough, (fig. 10) then loosen the screw to allow the drill to go further into the wheel for a deeper split. If the drill is split too much, (fig. 11) then turn the screw in a clock-wise direction, which prevents the point of the drill from going too much into the wheel. (Be sure to tighten the lock nut upon the final adjustment.)





Front Pivot Bolt

Depth
Adjustment
ScrewRear Pivot Bol
(not shown)

Fig.9



Fig. 10 Split too little

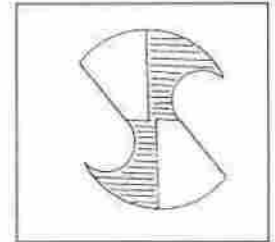

Fig. 11 Split too much

DAREX SP 2000 / SP 2500 CHUCK MAINTENANCE & ADJUSTMENT GUIDE

Disassembly:

Install chuck knob flats (A) in a vise. Put wrench jaws on the collet flats, (B) and loosen about 1 / 4 to 1 / 2 turn. Then pull chuck out of the knob.

Next, install the end of the chuck body in a vise, on the flats (C). Put a wrench on the flats near the nose, loosen and unscrew nose from the body.

Turn the sleeve, at the knob end of chuck, counter clockwise to remove it from the closing screw and in the process, the closing screw will exit out of the front of the chuck.

Important Note: If jaws need to be removed, they must be marked in their respective location, so as to go back in the same slots.

Clean closing screw and sleeve threads in an oil-less solvent, such as lacquer thinner or acetone, to remove any grit, filings and oil. A small brass brush aids this cleaning process.

Prior to reassembly, apply some powdered graphite on the closing screw and sleeve threads. Coat the threads with graphite by opening and closing the closing screw into the sleeve threads before putting them in the chuck body. Take care not to get graphite on the inner jaw surface.

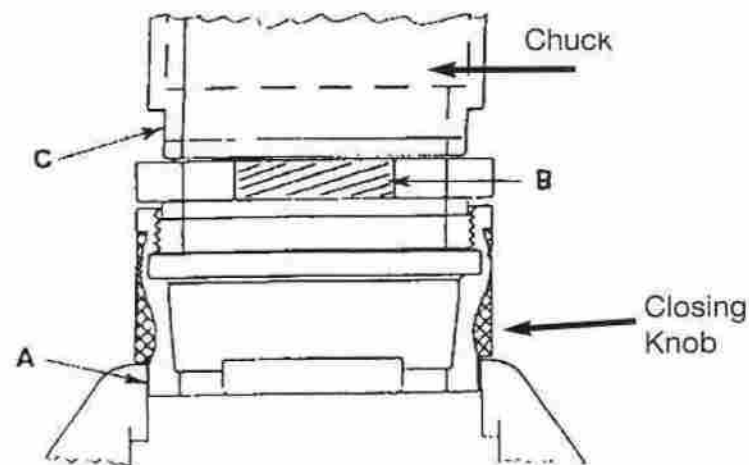

graphite on the inner jaw surface.

To reassemble, reverse the disassembly process. (be sure to tighten the chuck knob collet firmly so it will grip the sleeve securely)

To remove cams from the chucks: Insert chuck into alignment tube, as shown on page 3, picture 4. Place wrench on chuck body flats (area C above), rotate wrench counter clockwise to loosen cam, unscrew and remove over the nose of the chuck.

Problem: Chuck opens and closes with difficulty

A. Make sure threads are free of grit, oil-free and not damaged.

B. Check the jaw springs, make sure they are pushed all the way into the holes in the closing screw.

Problem: Knob turns and chuck won't tighten on the drill

A. After turning the chuck knob, if the sleeve inside the knob slips then the collet is not tight enough. A correction may be made by tightening the collet further into the knob.

B. Jaws turn with the knob: the key inside the chuck has broken loose. Return to the factory for repair.

Problem: Chuck won't grip drill bits tightly enough

A. The jaws may be bent. Close the chuck all the way and make sure the jaws line up with each other and appear straight. (replace if necessary)

B. Check the jaw springs and make sure they are pushed into the mounting holes located in the closing screw.

C. The chuck knob on the collet (B in above figure, may not be tight enough, thereby causing the chuck knob to rotate on the sleeve.

D. The closing screw and sleeve threads may be dirty with grit. Disassemble chuck and clean the parts as previously mentioned.

If you are unable to correct any problem, please contact Darex corporation, for further assistance: 1-800-547-0222.

10

DAREX SP CHUCK PARTS LIST

# ON DWG	PART#	DESCRIPTION
1	PPO2404SF	1/4", 5/8", & 1" THRUST WASHER
2	PPO2403SF	1/4" CHUCK ANTI-LOCK WASHER
3	PPO3640NF	CHUCK FELT SEAL (ALL CHUCKS)
4	SA02415SA	1/4" CHUCK JAWS (4)
4	SA02425SA	5/8" CHUCK JAWS (6)
4	SA02452SA	1" CHUCK JAWS (8 or 10)
5	PPO2418TF	1/16"-1/4" "HELICAL- S" POINT CHUCK CAM
5	PPO2428TF	1/4"-5/8" "HELICAL- S" POINT CHUCK CAM
5	PPO2448TF	5/8"-1" "HELICAL- S" POINT CHUCK CAM
6	PPO2600TF	1/16"-1/4" "SPLIT POINT" CHUCK CAM
6	PPO2602TF	1/4"-5/8" "SPLIT POINT" CHUCK CAM
6	PPO2604TF	5/8"-1" "SPLIT POINT" CHUCK CAM
NOT SHOWN	PPO2418TF	1/16"-1/4" LEFT HAND CHUCK CAM
NOT SHOWN	PPO2428TF	1/4"-5/8" LEFT HAND CHUCK CAM
7	SA03520RA	1/4" CHUCK JAW SPRINGS (4)
8	SA02421RA	5/8" CHUCK JAW SPRINGS (6)
8	SA02450RA	1" CHUCK JAW SPRINGS (8 or 10)
9	PPO2444TF	CHUCK KNOB COLLET
10	PPO2446TF	KNURLED CHUCK KNOB
11	SA02405TA	1/4" CHUCK BODY (INCLUDES KEY)
11	SA02405TA	5/8" CHUCK BODY (INCLUDES KEY)
11	SA02445TA	1" CHUCK BODY (INCLUDES KEY)

11	SA02405TA	5/8"	CHUCK BODY (INCLUDES KEY)
11	SA02445TA	1"	CHUCK BODY (INCLUDES KEY)
12	PPO2400TF	1/4"	CHUCK NOSE
12	PPO2420TF	5/8"	CHUCK NOSE
12	PPO2440TF	1"	CHUCK NOSE
13	PPO2401TF	1/4"	CHUCK SLEEVE
13	PPO2421TF	5/8"	CHUCK SLEEVE
13	PPO2441TF	1"	CHUCK SLEEVE
14	PPO2402TF	1/4"	CLOSING SCREW
14	PPO2422TF	5/8"	CLOSING SCREW
14	PPO2442TF	1"	CLOSING SCREW
NOT SHOWN	SA02400TA	1/16-1/4	"HELICAL- S" POINT CHUCK COMPLETE
NOT SHOWN	SA02420TA	1/4-5/8	"HELICAL- S" POINT CHUCK COMPLETE
NOT SHOWN	SA02440TA	5/8-1	"HELICAL- S" POINT CHUCK COMPLETE
NOT SHOWN	SA02403TA	1/16-1/4	"S" POINT MORSE TAPER #1 CHUCK
NOT SHOWN	SA02423TA	1/4-5/8	"S" POINT MORSE TAPER #2 CHUCK
NOT SHOWN	SA02600TA	1/16-1/4	"SPLIT POINT" CHUCK COMPLETE
NOT SHOWN	SA02620TA	1/4-5/8	"SPLIT POINT" CHUCK COMPLETE
NOT SHOWN	SA02640TA	5/8-1	"SPLIT POINT" CHUCK COMPLETE
NOT SHOWN	SA02605TA	1/16-1/4	LEFT HAND CHUCK
NOT SHOWN	SA02625TA	1/4-5/8	LEFT HAND CHUCK
NOT SHOWN	SA02603TA	1/16-1/4	"SPLIT POINT" MORSE TAPER #1 CHUCK
NOT SHOWN	SA02623TA	1/4-5/8	"SPLIT POINT" MORSE TAPER #2 CHUCK
NOT SHOWN	SA02604TA	1/16-1/4	MORSE TAPER #1 CHUCK-NO CAM
NOT SHOWN	SA02624TA	1/4-5/8	MORSE TAPER #2 CHUCK-NO CAM
NOT SHOWN	SA02602TA	1/16-1/4	CHUCK - NO CAM
NOT SHOWN	SA02622TA	1/4-5/8	CHUCK - NO CAM
NOT SHOWN	SA02642TA	5/8-1	CHUCK - NO CAM

Prices subject to change. (dated 8-16-1994)

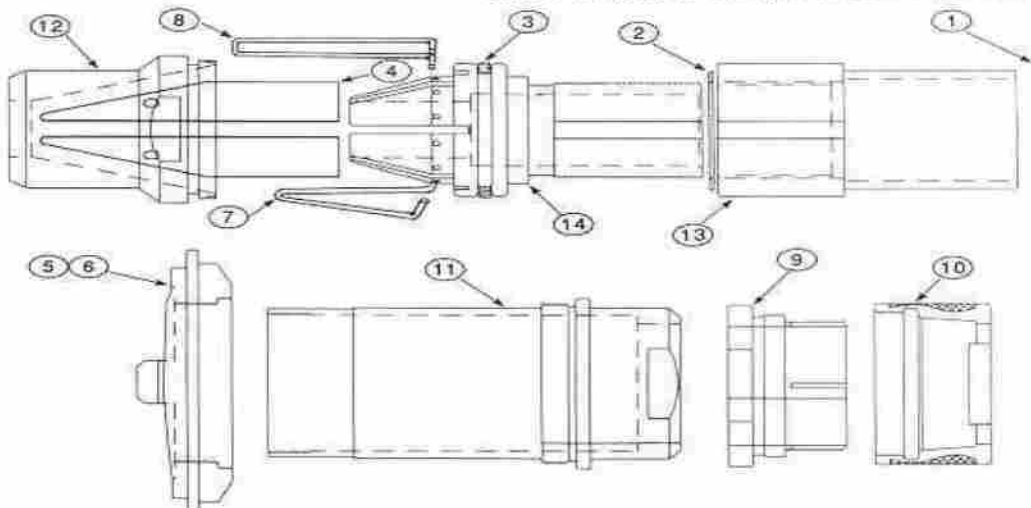

SAFETY INSTRUCTIONS

Darex operator information

Please read your instruction manual before operating the SP 2000 and SP 2500. While both machines are designed to be "user friendly" and every possible safety measure has been built in, we strongly advise you to familiarize yourself with this instruction manual before operating either Darex product.

ductor to a live terminal.

Check with a qualified electrician if the grounding instructions are not completely understood, or if in doubt as to whether the tool is properly grounded.

Use only 3-wire extension cords that have 3-prong grounding plugs and 3-pole receptacles that accept the tool's plug.



Important warning.

Severe damage to grinding wheel will result if

**Important warning.**

Severe damage to grinding wheel will result if you attempt to sharpen a carbide drill on a Borazon (CBN) grinding wheel. The Borazon grinding wheel is for HSS (high speed steel) or cobalt drills only. For carbide drills use a Darex diamond wheel only. Conversely, diamond wheels are not recommended for "softer metals" such as HSS drills. Soft metal drills will coat the diamond wheel reducing its sharpening ability.

**Caution:**

For your own safety, please read instruction manual before operating sharpener.

Always disconnect sharpener from the power supply when replacing parts or repairing interior parts..

Installation

Check sharpener nameplate to make certain the rating is correct for the power supply, voltage and frequency. Place sharpener on a solid bench. If your SP is mounted on a stand make sure machine is securely fastened to stand and stand is bolted to the floor

Operation

Insert plug into receptacle and turn on switch. Sharpener should come up to speed smoothly and without vibration.

Maintenance

Little maintenance, other than emptying grit box, replacement of light bulb and eventually the replacement of the grinding wheel is needed. (See routine maintenance, page 6)

**A. Grounding Instructions**

All grounded, cord connected tools:

In the event of a malfunction or breakdown, grounding provides the path of least resistance for electric current to reduce the risk of electric shock. This tool is equipped with an electric cord having an equipment-grounding conductor and a grounding plug. The plug must be plugged into a matching outlet that is properly installed and grounded in accordance with all local codes and ordinances.

Do not modify the plug provided; if it will not fit the outlet, have the proper outlet installed by a qualified electrician. Improper connection of the equipment-grounding conductor can result in a risk of electrical shock. The conductor with insulation, having the outer surface that is green with or without yellow stripes, is the equipment grounding conductor. If repair or replacement of the electric cord is necessary, do not connect the equipment-grounding con-

plugs and 3-pole receptacles that accept the tool's plug.

Repair or replace damaged or worn cord immediately.

Grounded, cord-connected tools intended for use on a supply circuit having a nominal rating less than 150 volts.

Grounded, cord connected tools intended for use on a supply circuit having a nominal rating between 150-250 volts, inclusive.

**B. Safety tips for all tools**

Keep work area clean. Cluttered areas and benches invite accidents.

Don't use in a dangerous environment. Don't use power tools in damp locations, or expose them to rain. Keep work area well lit.

Don't force the tool. It will do the job better and safer at the rate for which it was designed.

Use the right tool. Don't force tool or attachment to do a job it was not designed for.

Keep children away from all power tools.

Wear proper apparel. No loose clothing neckties, rings, bracelets, or other jewelry to get caught in moving parts. Non-slip footwear is recommended. Wear protective hair covering to contain long hair. Safety glasses are recommended

Don't overreach. Keep proper footing and balance at all times.

Maintain tools. Keep tools sharp and clean for best and safest performance. Follow instruction for lubrication and changing accessories.

Disconnect tools before servicing; when changing accessories.

Use the recommended accessories. Consult the owner's manual for recommended accessories.

Never stand on tool. Serious injury could occur.

Check damaged parts. Before further use of the tool, check part that is damaged for proper operation, alignment and performance.

Never leave tool running unattended. Turn power off.

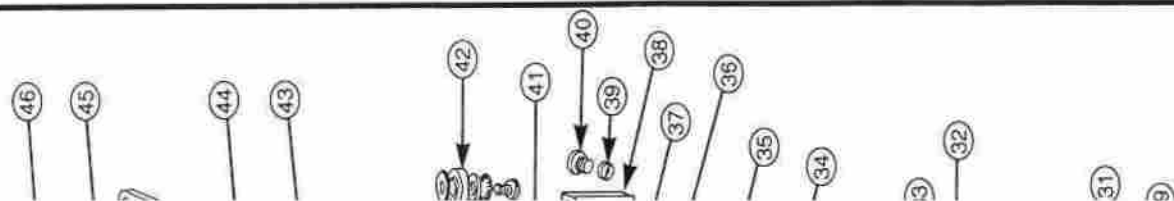

DAREX
220 Hersey Street • Ashland OR • 97520
1-800-547-0222

SP 2500 Drill Sharpener

