

# Atlas Copco Stationary air compressors

## L series

Oil lubricated and oil-free piston compressors

0.75 - 20 hp / 0.55 - 15 kW



LONG LIFE  
LOW MAINTENANCE

*Atlas Copco*

# Atlas Copco's L-range of durable oil-free and oil lubricated piston compressors, designed for reliable continuous duty and minimum maintenance

The L-range of oil-free and oil lubricated compressors are available in a number of product variants to match the exact needs of a wide range of end users.

They are available as standard "core" units, with the possibility to add a number of standard options, giving the flexibility to match the individual application requirements.

**LFx** Unique single stage oil-free compressor with a maximum working pressure up to 10 bar(e) for applications between 1.0 and 2.5 l/s.

## **LF**

Unique single and two stage oil-free compressor with a maximum working pressure of 10 bar(e) for continuous duty applications between 3 and 17 l/s.

## **LE**

Single and two stage oil lubricated compressor with a maximum working pressure of 10 bar(e) with capacities from 3.4 up to 29 l/s.

## **LT**

Two stage oil lubricated compressor with a maximum working pressure of 30 bar(e) with capacities from 3 up to 20 l/s.



# Features achieved with innovative design and highest quality materials

## LFx compressor block

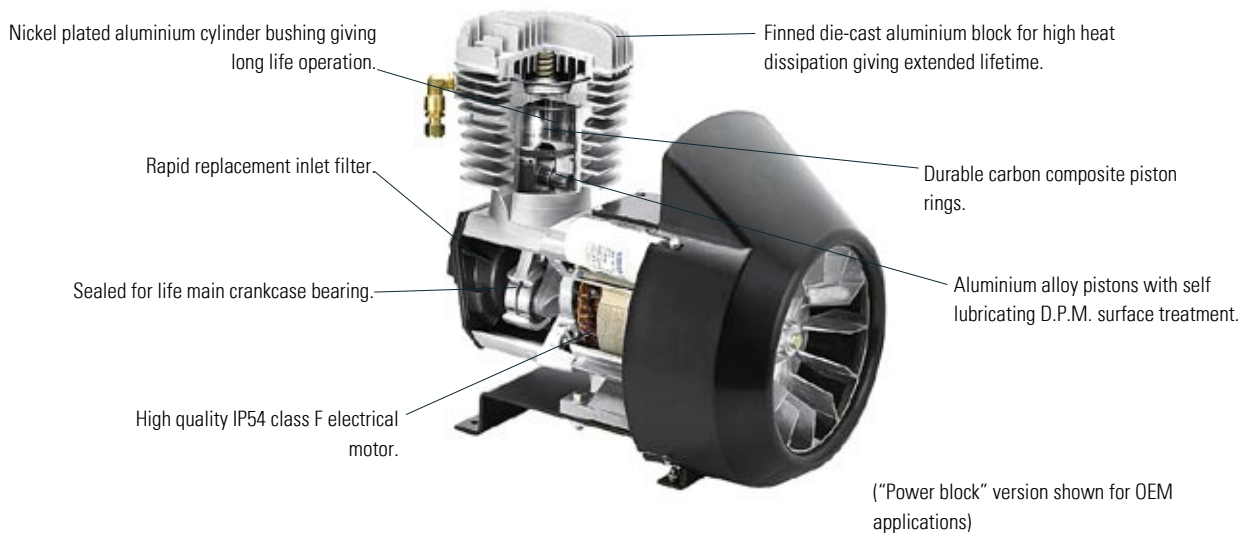

## LF, LE and LT compressor block

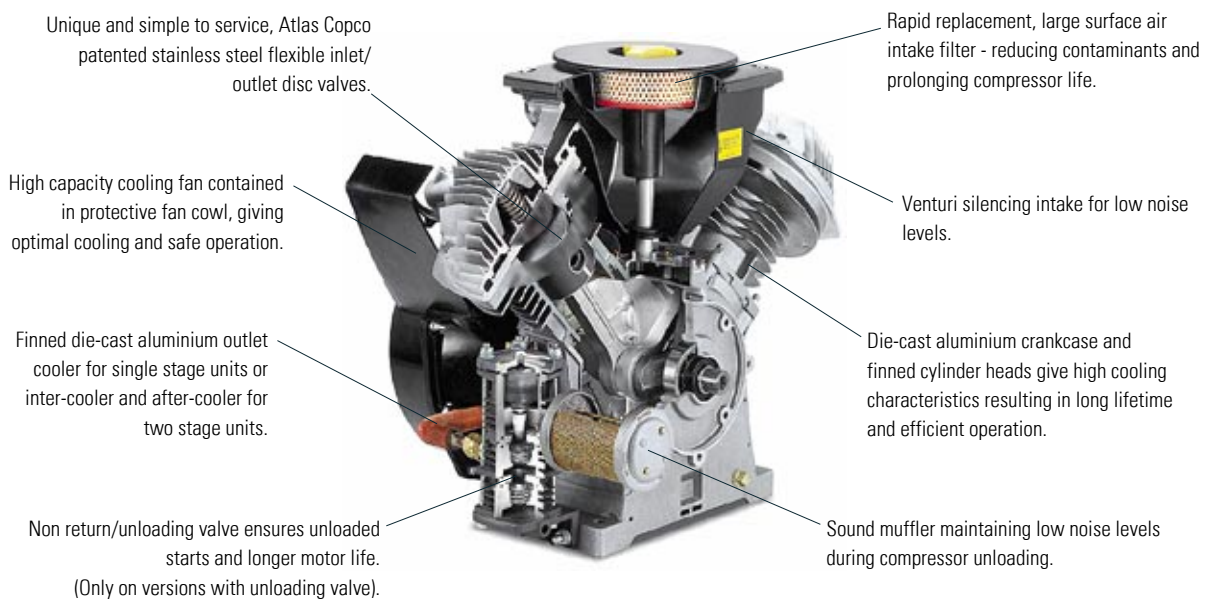

# LFx low capacity oil-free air compressor... compact and virtually maintenance free.

The unique design and combination of materials within the LFx compressor gives you the following benefits:

- Virtually maintenance-free operation<sup>(\*)</sup>
- Continuous duty operation
- Guaranteed 100 % oil-free operation
- Compact and quiet operation [61 to 64 dB(A)

standard].

The variants of LFx models available give both end users or OEM customers flexibility, choice and reliability.

<sup>(\*)</sup> Limited to air inlet filter change.

## Suction



## Compression



This unique Atlas Copco designed inlet system gives high efficiency operation, which offers more compressed air for each kW power consumed.

## Power box



Complete silenced, self-contained single cylinder compressor/motor package, including a thermal electrical motor protection on single phase units. The power box serves as a complete replacement package for receiver mounted units or for custom OEM applications. (Option: manifold, including regulator, pressure gauge, outlet connection).

## Trolley units



Power box mounted on an internally epoxy painted 20 litre air receiver (CE/AS1210 for 50 Hz, ASME for 60 Hz), including regulation, safety valve, pressure regulator, regulated outlet valve, pressure gauges and trolley frame. Overload protection is included for 3-phase units. A complete silenced and mobile oil-free compressor installation.

## Complete unit on air receiver



Power box mounted on an internally epoxy painted 50 or 100 litre air receiver, including regulation, safety valve, pressure regulator, outlet valve and pressure gauge. The complete silenced compressed air installation. For 60 Hz units, receivers are ASME approved as standard. For 50 Hz units, receivers are CE/AS1210 (only 50 l) approved.

# LF single stage oil-free and LE/LT single and two stage oil lubricated piston compressors ... reliability and durability

The LE/LT range of oil lubricated piston compressors are available in a number of product variants to match the exact needs of a wide range of end users. Oil carry over levels for these machines are very low (< 0.1 g/kW/h) making the units ideal for continuous duty, mainstream industrial applications and in combination with Atlas Copco quality air products - DD/PD filters, FD refrigerant and CD adsorption air dryers - give the possibility of high quality air packages for more sensitive applications.

The LF piston range from Atlas Copco is amongst a number of products designed and built with both industrial applications and the environment in mind. They include sealed for life main bearings, nickel plated cylinders and teflon coated aluminium pistons. This unique combination of materials applied to the proven Atlas Copco block design gives you:

- guaranteed no oil in the system, avoiding contamination of processes
- an oil-free unit designed for continuous duty with low maintenance
- a perfect alternative to oil lubricated compressors for mainstream industrial applications, or combined with Atlas Copco quality air products offers the best value, highest quality, small capacity compressed air package on the market today.

## **Base versions**



Block and Power pack (block with directly flanged IP55 electric motor) are available for replacement in existing L-installations or for specialised OEM applications.

## **Base mount version**



A complete self-contained operational compressor as above, but mounted on a common base frame for floor mounting or mounting on a locally sourced air receiver. Available with or without silencing canopy.

## **Receiver mounted**



A complete compressed air station including pre-wired starting and regulation equipment, mounted on a CE approved air receiver.

## **Receiver mounted LE/LT/LF FFwith refrigerant air dryer and filters (DD/PD)**



A complete compressed air station including refrigerant air dryer, pre-wired starting and regulation equipment, mounted on an air receiver.

# Technical data

Compressor type	FAD at normal working pressure and 1500 rpm (50 Hz)		FAD at normal working pressure and 1800 rpm (60 Hz)		Maximum working pressure		Installed recommended power		Noise level dB(A)		
	l/s	cfm	l/s	cfm	bar	psi	kW	hp	Unsilenced	Complete unit silenced	Base mounted silenced

## 10 bar - oil-free LFx, LF

LFx-0.7	1.02	2.16	1.35	2.86	10	145	0.55	0.75	62	62	-
LFx-1.0	1.38	2.92	1.46	3.09	10	145	0.75	1.00	62	62	-
LFx-1.5	2.07	4.39	2.39	5.06	10	145	1.10	1.50	64	64	-
LFx-2.0	2.53	5.36	-	-	10	145	1.50	2.00	64	64	-
LF 2-10	3.10	6.57	3.60	7.63	10	145	1.5	2.0	82	69	67
LF 3-10	4.00	8.48	4.60	9.75	10	145	2.2	3.0	83	70	68
LF 5-10	7.60	16.10	8.80	18.65	10	145	4.0	5.5	83	70	68
LF 7-10	9.20	19.49	10.70	22.67	10	145	5.5	7.5	84	74	72
LF 10-10	14.40	30.50	17.10	36.23	10	145	7.5	10.0	86	77	74

## 10 bar - oil lubricated LE

LE 2-10	3.40	7.20	3.90	8.26	10	145	1.5	2.0	80	67	65
LE 3-10	4.40	9.32	5.10	10.80	10	145	2.2	3.0	81	68	66
LE 5-10	8.40	17.80	9.70	20.55	10	145	4.0	5.5	81	68	66
LE 7-10	11.70	24.80	13.60	28.17	10	145	5.5	7.5	82	72	70
LE 10-10	15.70	33.27	17.40	36.87	10	145	7.5	10.0	83	72	70
LE 15-10	18.60	39.06	21.90	46.40	10	145	11.0	15.0	86	73	70
LE 20-10	23.90	50.19	28.90	61.27	10	145	15.0	20.0	86	73	70

## High pressure range

### 15 bar - oil lubricated LT

LT 2-15	3.20	6.77	3.60	7.63	15	218	1.5	2.0	80	67	65
LT 3-15	4.10	8.68	4.80	10.17	15	218	2.2	3.0	81	68	66
LT 5-15	6.70	14.20	7.90	16.74	15	218	4.0	5.5	81	68	66
LT 7-15	9.20	19.49	10.90	23.10	15	218	5.5	7.5	82	72	70
LT 10-15	11.70	24.79	-	-	15	218	7.5	10.0	83	72	70

### 20 bar - oil lubricated LT

LT 2-20	2.20	4.80	2.80	5.93	20	290	1.5	2.0	80	67	65
LT 3-20	3.00	6.35	3.70	7.84	20	290	2.2	3.0	81	68	66
LT 5-20	5.00	10.59	6.30	13.35	20	290	4.0	5.5	81	68	66
LT 7-20	6.70	14.19	8.40	17.80	20	290	5.5	7.5	82	72	70
LT 10-20	9.10	19.28	-	-	20	290	7.5	10.0	83	72	70
LT 15/60-20	-	-	11.90	26.18	20	290	11.0	15.0	88	81	75
LT 15-20	15.10	32.00	17.70	37.50	20	290	11.0	15.0	89	85	75
LT 20-20	18.00	38.13	20.91	44.30	20	290	15.0	20.0	88	83	77

### 30 bar - oil lubricated LT

LT 3-30	2.80	6.10	3.30	7.19	30	435	2.2	3.0	81	-	66
LT 5-30	4.90	10.38	5.60	11.86	30	435	4.0	5.5	81	-	67
LT 7-30	6.40	13.56	8.00	16.95	30	435	5.5	7.5	82	-	67
LT 10-30	8.50	18.01	-	-	30	435	7.5	10.0	83	-	70
LT 15-30	9.28	19.66	11.1	23.52	30	435	11.0	15.0	85	-	76
LT 20-30	17.0	36.04	19.70	41.76	30	435	15.0	20.0	86	-	80

LE / LT / LF 2-10 with integrated refrigerant dryers and filter package.



# Features and options

Atlas Copco L-series compressors are available as standard "core" units, with the possibility to add a number of standard options, giving the flexibility to match the individual application requirements.

All standard "options" are mounted and tested prior to leaving the factory or are available as sales kit versions for retrofitting in the field.

All LF/LE/LT compressors can be delivered with:

- higher capacity air receiver
- galvanised air receiver
- heavy duty inlet filter
- inter-stage condensate drain
- silenced canopy

L compressors can also be adapted for special applications such as:

- in tram and light rail vehicles for the air suspension, pantograph lifting and other auxiliary applications,
- for snow making in extreme conditions encountered within the mountain environment,
- an unique skid mounted unit for marine propulsion applications.

## Cost of ownership

Piston compressors for smaller applications are the most economical way to produce compressed air,

- Minimum Specific energy required
- Minimum maintenance cost
- Easy to serve
- Long lifetime
- simple usage

### Mounted CD dryers



CD mounted dryers. A complete dryer/filter Package, pre-mounted to provide a self contained high quality air centre.

### Heavy duty Filters



Protect your production machinery from oil, dust and sludge by use of filters.

The dryer filter combination will reduce downtime and ensure that the compressed air remain clean and dry.

### CDFX desiccant dryer



-CDFX mounted desiccant air dryers available on receiver mounted and trolley versions giving a compact oil-free and dry air supply.

- automatic condensate drain
- galvanised air receiver.

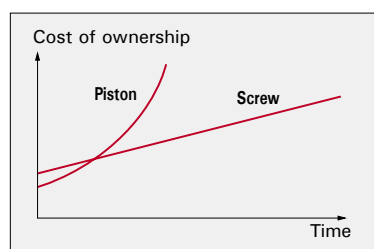



The face of innovation

What sets Atlas Copco apart as a company is our conviction that we can only excel in what we do if we provide the best possible know-how and technology to really help our customers produce, grow and succeed.

There is a unique way of achieving that - we simply call it the Atlas Copco way. It builds on interaction, on long-term relationships and involvement in the customers' process, needs and objectives. It means having the flexibility to adapt to the diverse demands of the people we cater for.

It's the commitment to our customers' business that drives our effort towards increasing their productivity through better solutions. It starts with fully supporting existing products and continuously doing things better, but it goes much further, creating advances in technology through innovation. Not for the sake of technology, but for the sake of our customer's bottom line and peace-of-mind.

That is how Atlas Copco will strive to remain the first choice, to succeed in attracting new business and to maintain our position as the industry leader.



#### **Service competence**

Atlas Copco is committed to provide the levels of after-sales care that you require. Our highly trained engineers offer the best possible support and assistance in operating your equipment with the most modern diagnostic tools available.

#### **Global capability**

Global capability with local presence means that we can respond rapidly to any situation anywhere in the world. Our world class logistics ensures timely delivery of our range of guaranteed quality spare parts.



#### **ISO 9001**

From design to production and delivery of compressors, Atlas Copco adheres to the ISO 9001 management system.



#### **ISO 14001**

Atlas Copco's Environmental Management System forms an integral part of each business.

Never use compressed air as breathing air without prior purification in accordance with local legislation and standards.

**Atlas Copco**

[www.atlascopco.com](http://www.atlascopco.com)