

TECHNICAL MANUAL

**OPERATOR, UNIT, INTERMEDIATE DIRECT SUPPORT
AND GENERAL SUPPORT MAINTENANCE MANUAL
(INCLUDING REPAIR PARTS AND
SPECIAL TOOLS LISTS)**

**POWER PLANT
AN/MJQ-15 (NSN 6115-00-400-7591)
(2) MEP-113A 15 KW 400 HZ
GENERATOR SETS
(2) M200A1 2-WHEEL, 4-TIRE,
MODIFIED TRAILERS**

Approved for public release; distribution is unlimited.

This manual supersedes Chapter 9 of TM 5-6115-594-14&P dated 25 September 1984.

HEADQUARTERS, DEPARTMENT OF THE ARMY

20 JUNE 1988

CHANGE

NO. 4

HEADQUARTERS
DEPARTMENT OF THE ARMY
WASHINGTON, D.C., 15 DECEMBER 1993

Operator, Unit, Intermediate Direct Support
and General Support Maintenance Manual
(Including Repair Parts and Special Tools Lists)

POWER PLANT
AN/MJQ-15 (NSN 6115-00-400-7591)
(2) MEP-113A 15 KW 400 HZ
GENERATOR SETS
(2) M200A1 2-WHEEL, 4-TIRE,
MODIFIED TRAILERS

DISTRIBUTION STATEMENT A: Approved for public release; distribution is unlimited.

TM 5-6115-628-14&P, 20 June 1988, is changed as follows:

1. Remove and insert pages as indicated below. New or changed text material is indicated by a vertical bar in the margin. An illustration change is indicated by a miniature pointing hand.

Remove pages

4-7 and 4-8

Insert pages

4-7 and 4-8

2. Retain this sheet in front of manual for reference purposes.

DISTRIBUTION :

To be distributed in accordance with DA Form 12-25-E, block no. 3864, requirements for TM 5-6115-628-14&P.

CHANGE

NO. 3

HEADQUARTERS
DEPARTMENT OF THE ARMY
WASHINGTON, D.C., 3 JUNE 1991

Operator, Unit, Intermediate Direct Support
and General Support Maintenance Manual
(Including Repair Parts and Special Tools List)

POWER PLANT
AN/MJQ-15 (NSN 6115-00-400-7591)
(2) MEP-113A, 15 kW, 400 HZ
GENERATOR SETS
(2) M200A1, 2-WHEEL, 4-TIRE,
MODIFIED TRAILERS

Approved for public release; distribution is unlimited

Current as of 7 March 1991

TM 5-6115-628-14&P, 20 June 1988 is changed as follows:

1. Remove and insert pages as indicated below. New or changed text material is indicated by a vertical bar in the margin. An illustration change is indicated by a miniature pointing hand.

Remove pages

Insert pages

B-1 and B-2

B-1 and B-2

2. Retain this sheet in front of manual for reference purposes.

By Order of the Secretary of the Army:

CARL E. VUONO
General, United States Army
Chief of Staff

Official:

PATRICIA P. HICKERSON
Colonel, United States Army
The Adjutant General

DISTRIBUTION:

To be distributed in accordance with DA Form 12-25E, (qty rqr block no. 3864).

CHANGE

NO. 2

HEADQUARTERS
DEPARTMENT OF THE ARMY
WASHINGTON, D.C., 18 January 1991

Operator, Unit, Intermediate Direct Support
and General Support Maintenance Manual
(Including Repair Parts and Special Tools List)

POWER PLANT
AN/MJQ-15 (NSN 6115-00-400-7591)
(2) MEP-113A 15 KW 400 HZ
GENERATOR SETS
(2) M200A1 2-WHEEL, 4-TIRE,
MODIFIED TRAILERS

Approved for public release; distribution is unlimited

Current as of 1 January 1991.

TM 5-6115-628-14&P, 20 June 1988, is changed as follows:

1. Remove and insert pages as indicated below. New or changed text material is indicated by a vertical bar in the margin. An illustration change is indicated by a miniature pointing hand.

Remove pages

c/(d blank)
3-11 through 3-14
B-3/(B-4 blank)
D-17 and D-18

Insert pages

c/(d blank)
3-11 through 3-14
B-3/(B-4 blank)
D-17 and D-18

2. Retain this sheet in front of manual for reference purposes.

By Order of the Secretary of the Army:

CARL E. VUONO
General, United States Army
Chief of Staff

Official:

THOMAS F. SIKORA
Brigadier General, United States Army
The Adjutant General

DISTRIBUTION:

To be distributed in accordance with DA Form 12-25E, (qty rqr block no. 3864)

CHANGE }
NO. 1 }

HEADQUARTERS
DEPARTMENT OF THE ARMY
WASHINGTON, D.C., 9 October 1989

Operator, Unit, Intermediate Direct Support
and General Support Maintenance Manual
(Including Repair Parts and Special Tools Lists)

POWER PLANT
AN/MJQ-15 (NSN 6115-00-400-7591)
(2) MEP-113A 15 KW 400 HZ
GENERATOR SETS
(2) M200A1 2-WHEEL, 4-TIRE,
MODIFIED TRAILERS

Approved for public release; distribution is unlimited.

TM 5-6115-628-14&P, 20 June 1988, is changed as follows:

1. Remove and insert pages as indicated below. New or changed text material is indicated by a vertical bar in the margin. An illustration change is indicated by a miniature pointing hand.

Remove pages

Insert pages

3-19/3-20

3-19/3-20

4-9 through 4-14

4-9 through 4-14

2. Retain this sheet in front of manual for reference purposes.

By Order of the Secretary of the Army:

CARL E. VUONO
General, United States Army
Chief of Staff

Official:

WILLIAM J. MEEHAN, II
Brigadier General, United States Army
The Adjutant General

DISTRIBUTION:

To be distributed in accordance with DA Form 12-25A, Unit, Direct Support and General Support Maintenance requirements for Generator Set, Diesel Engine Driven, Trailer Mounted.



**SAFETY STEPS TO FOLLOW IF SOMEONE IS THE
VICTIM OF ELECTRICAL SHOCK**

DO NOT TRY TO PULL OR GRAB THE INDIVIDUAL

IF POSSIBLE, TURN OFF THE ELECTRICAL POWER

**IF YOU CANNOT TURN OFF THE ELECTRICAL
POWER, PULL, PUSH, OR LIFT THE PERSON TO
SAFETY USING A WOODEN POLE OR A ROPE OR
SOME OTHER INSULATING MATERIAL**

SEND FOR HELP AS SOON AS POSSIBLE

**AFTER THE INJURED PERSON IS FREE OF
CONTACT WITH THE SOURCE OF ELECTRICAL
SHOCK, MOVE THE PERSON A SHORT DISTANCE
AWAY AND IMMEDIATELY START ARTIFICIAL
RESUSCITATION**

WARNING

All specific cautions and warnings contained in this manual shall be strictly adhered to. Otherwise, severe injury, death and/or damage to the equipment may result.

HIGH VOLTAGE

is produced when this power plant is in operation.

DEATH

or severe burns may result if personnel fail to observe safety precautions. Do not operate this power plant until the ground terminal studs have been connected to a suitable ground. Disconnect the battery ground cable on the generator set before removing and installing components on the engine or in the electrical control panel system. Remove all rings, watches, and other jewelry when performing maintenance on this equipment. Loose fitting clothing should be secured to prevent it catching in moving parts. Do not attempt to service or otherwise make any adjustments, connections or reconnection of wires or cables until generator set is shut down and completely de-energized.

DANGEROUS GASES

Batteries generate explosive gas during charging: therefore, utilize extreme caution. Do not smoke, or use open flame in the vicinity of the generator sets when servicing batteries.

Exhaust discharge contains noxious and deadly fumes. Do not operate power plant generator sets in enclosed areas unless exhaust discharge is properly vented to the outside.

To avoid sparking between filler nozzle and fuel tank, always maintain metal to metal contact between filler nozzle and fuel tank when filling generator set fuel tanks.

Do not smoke or use open flame in the vicinity of the power plant while fueling generator sets.

LIQUIDS UNDER HIGH PRESSURE

are generated as a result of operation of the power plant generator sets. Do not expose any part of the body to a high pressure leak in the fuel injection system.

NOISE

Operating noise level of the generator set can cause hearing damage. Ear protectors, as recommended by the medical or safety officer, must be worn when working near this power plant.

WARNING

Clean parts in a well-ventilated area. Avoid inhalation of solvent fumes and prolonged exposure of skin to cleaning solvent. Wash exposed skin thoroughly. Dry cleaning solvent (P-D-680) used to clean parts is potentially dangerous to personnel and property. Do not smoke or use near open flame or excessive heat. Flash point of solvent is 100°F to 138°F (38°C to 59°C).

WARNING

Hot refueling of generators while they are running poses a safety hazard and should not be attempted. Hot engine surfaces and sparks produced from the engine and generator circuitry are possible sources of ignition. Severe injury, death and/or damage to equipment may result.

TECHNICAL MANUAL 5-6115-628-14&P

HEADQUARTERS
DEPARTMENT OF THE ARMY
WASHINGTON, DC, 20 June, 1988

**Operator, Unit, Intermediate Direct Support and General Support
Maintenance Manual (Including Repair Parts and Special Tools Lists)
for
POWER PLANT, AN/MJQ-15
(NSN 6115-00-400-7591)
(2) MEP-113A 15 KW 400 HZ GENERATOR SETS
(2) M200A1 2-WHEEL, 4-TIRE, MODIFIED TRAILERS**

	Page
CHAPTER 1.	INTRODUCTION
Section I.	General 1-1
Section II.	Description and Data 1-2
CHAPTER 2.	OPERATING INSTRUCTIONS
Section I.	Operating Procedures 2-1
Section II.	Operation of Auxiliary Equipment 2-3
Section III.	Operation Under Unusual Conditions 2-4
CHAPTER 3.	OPERATOR/CREW MAINTENANCE INSTRUCTIONS
Section I.	Consumable Operating and Maintenance Supplies 3-1
Section II.	Lubrication Instructions 3-1
Section III.	Preventive Maintenance Checks and Services (PMCS) 3-1
Section IV.	Troubleshooting 3-19
Section V.	Operator/Crew Maintenance 3-19
CHAPTER 4.	UNIT MAINTENANCE
Section I.	Service Upon Receipt of Equipment 4-1
Section II.	Movement to a New Worksite 4-7
Section III.	Repair Parts, Special Tools, Special Test, Measurement and Diagnostic Equipment (TMDE) 4-8
Section IV.	Lubrication Instructions 4-8
Section V.	Preventive Maintenance Checks and Services 4-9
Section VI.	Troubleshooting 4-14
Section VII.	Radio Interference Suppression 4-15
Section VIII.	Maintenance of Power Plant Trailers 4-16
Section IX.	Maintenance of Electrical System 4-26

Approved for public release; distribution is unlimited.

This manual supersedes Chapter 9 of TM 5-6115-594-14&P dated 25 September 1984.

CHAPTER 5.	INTERMEDIATE (FIELD), DIRECT SUPPORT AND GENERAL SUPPORT MAINTENANCE INSTRUCTIONS	
Section I.	Introduction	5-1
Section II.	Maintenance of Power Plant Trailers	5-1
Section III.	Generator Set	5-3
Section IV.	Maintenance of Electrical System	5-5
CHAPTER 6.	TEST AND INSPECTION AFTER REPAIR	
Section I.	General Requirements	6-1
Section II.	Inspection	6-1
Section III.	Operational Tests	6-1
APPENDIX A.	REFERENCES	A-1
APPENDIX B.	COMPONENTS OF END ITEM AND BASIC ISSUE ITEMS LISTS	B-1
APPENDIX C.	MAINTENANCE ALLOCATION CHART	C-1
APPENDIX D.	UNIT, INTERMEDIATE (FIELD) (DIRECT SUPPORT AND GENERAL SUPPORT) AND DEPOT MAINTENANCE REPAIR PARTS AND SPECIAL TOOLS LIST	D-1

LIST OF ILLUSTRATIONS

Figure	Title	Page
1-1	Power Plant, Curbside Front, Three-Quarter View	1-3
1-2	Power Plant, Roadside Rear, Three-Quarter View	1-4
4-1	Power Unit B, with Switch Box, Packed for Shipment	4-1
4-2	Unpacking Power Plant - Power Unit B Shown	4-2
4-3	Power Plant Installation	4-6
4-4	External Fuel Line Connection	4-7
4-5	Fuel Can Bracket Replacement	4-16
4-6	Accessory Box Replacement	4-17
4-7	Fire Extinguisher Bracket Replacement	4-18
4-8	Front Steps Replacement	4-20
4-9	Rear Steps Replacement	4-22
4-10	Fender Replacement	4-23
4-11	Personnel Platform Replacement	4-25
4-12	Holddown Strap Replacement	4-26
4-13	Power Cable Wiring Diagram	4-27
4-14	Switch Box Wiring Diagram	4-30
4-15	Connector Replacement	4-31
4-16	Load Terminal Replacement	4-32
5-1	Accessory Box Repair	5-1
5-2	Power Plant Markings	5-2
5-3	Detaching Generator Set From Trailer	5-3
5-4	Lifting Generator Set	5-4
5-5	Power Cable Repair	5-6
5-6	Switch Box Replacement	5-8
B-1	Components of End Item	B-2
B-2	Basic Issue Items	B-3
D-1	Generator Set	D-10
D-2	Power Cables	D-12
D-3	Switch Box Assembly	D-15
D-4	Switch Box	D-24
D-5	Switch Box Cable Assemblies and Harness Assembly	D-26
D-6	Ground Wire Assembly and Electrical Leads	D-28
D-7	Trailer Body	D-32
D-8	Accessory Box	D-36
D-9	Front Steps	D-38
D-10	Rear Steps	D-40
D-11	Fenders	D-42
D-12	Personnel Platform	D-44
D-13	Handbrakes	D-46

LIST OF TABLES

Number	Title	Page
3-1	Consumable Operating and Maintenance Supplies	3-1
3-2	Operator/Crew Preventive Maintenance Checks and Services (PMCS)	3-4
4-1	Unit Preventive Maintenance Checks and Services (PMCS)	4-10
4-2	Troubleshooting	4-14

CHAPTER 1

INTRODUCTION

Section I. GENERAL

1-1. Scope. This manual is for your use in operating and maintaining the Power Plant, AM/MJQ-15. The AN/MJQ-15 is a mobile power plant used to supply 15 KW of 400 Hz input operating power to the Fire Direction Control Center for Artillery. In addition to operating instructions and operator, unit, and intermediate direct support and general support maintenance procedures, this manual contains a Repair Parts and Special Tools List for the power plant.

1-2. Limited Applicability. Some portions of this publication are not applicable to both services. These portions are prefixed to indicate the service to which they pertain: (A) for Army, and (F) for Air Force. Portions not prefixed are applicable to both services.

1-3. Maintenance Forms and Records.

- a. (A) Maintenance forms and records used by Army personnel are prescribed by DA Pam 738-750.
- b. (F) Maintenance forms and records used by Air Force personnel are prescribed in AFM66-1 and the applicable 00-20 Series Technical Orders.

1-4. Reporting of Errors. Reporting of errors and omissions and recommendations for improvement of this publication by the individual user is encouraged. Reports should be submitted as follows:

- a. (A) Army - DA Form 2028 directly to: Commander, US Army Troop Support Command, ATTN: AMSTR-MCTS, 4300 Goodfellow Boulevard, St. Louis, MO, 63120-1798.
- b. (F) Air Force – AFTO Form 22 directly to: Commander, Sacramento Air Logistics Center, ATTN: SM-ALC-MMEDTA, McClellan Air Force Base, CA, 95652-5609, in accordance with TO-00-5-1.

1-5. Reporting Equipment Improvement Recommendations (EIR). EIR's will be prepared using SF 368 Product Quality Deficiency Report. Instructions for preparing EIR's are provided in DA Pam 738-750, The Army Maintenance Management System. EIR's should be mailed directly to: Commander, US Army Troop Support Command, ATTN: AMSTR-QX, 4300 Goodfellow Boulevard, St. Louis, MO, 63120-1798.

1-6. Levels of Maintenance Accomplishment.

- a. (A) Army users shall refer to the Maintenance Allocation Chart (MAC) for tasks and levels of maintenance to be performed.
- b. (F) Air Force users shall accomplish maintenance at the user level consistent with their capability in accordance with policies established in AFM 66-1.

1-7. Destruction of Army Materiel. Destruction of Army materiel to prevent enemy use shall be in accordance with TM 750-244-3.

1-8. Administrative Storage.

- a. Army equipment placed in administrative storage will have preventive maintenance performed in accordance with the PMCS tables before storage. When equipment is removed from storage, PMCS will be performed to ensure operational readiness.
- b. (F) For administrative storage procedures for Air Force equipment, refer to TO 35-1-4, Processing and Inspection of Aerospace Ground Equipment for Storage and Shipment.

1-9. Preparation for Shipment and Storage.

- a. (A) Army - Refer to TB 740-97-2.
- b. (F) Air Force - Refer to TO 35-1-4 for component of end item generator sets and TO 38-1-5 for installed engine.

Section II. DESCRIPTION AND DATA

1-10. Description. Power Plant AN/MJQ-15 is made up of two PU-732/M power units. Each power unit is, in turn, made up of one Tactical Precise Generator Set, DOD Model MEP-113A mounted on a modified M200A1 trailer. These generator sets are liquid-cooled, diesel engine-driven units, each with a load capacity of 15 KW at 400 Hz. The trailers are two-wheeled units with dual tires mounted. Each trailer has a 2 1/2-ton carrying capacity. The modifications to the basic trailers provide stowage for the accessories and all equipment necessary for mobile operation as well as providing a work platform for the operator and maintenance personnel. Output from the power plant is applied to the system or equipment being powered through a switch box. Figures 1-1 and 1-2 illustrate the power plant.

1-11. Tabulated Data. The tabulated data provides operator and unit level personnel with the dimensions and weights for Power Plant, AN/MJQ-15. These specifications are computed from the combined dimensions and weights of the two power units that make up the power plant. Specifications for a single PU-732/M power unit can be found in TM 5-6115-594-14&P. For additional information concerning Generator Set DOD Model MEP-113A, refer to TM 5-6115-464-12, - 34, and - 24P. For additional information on the M200A1 trailer, refer to TM 9-2330-205-14&P. The tabulated data also includes the location and content of all data plates unique to the power plant.

a. Identification, Information, and Warning Plates.

(1) Modification identification plate.

(a) Location. This plate is located on front roadside frame between the trailer body and lunette.

(b) Content.

**MODIFIED FOR POWER PLANT AN/MJQ-15
NSN 6115-00-400-7591
UNIT A (or B, as applicable)**

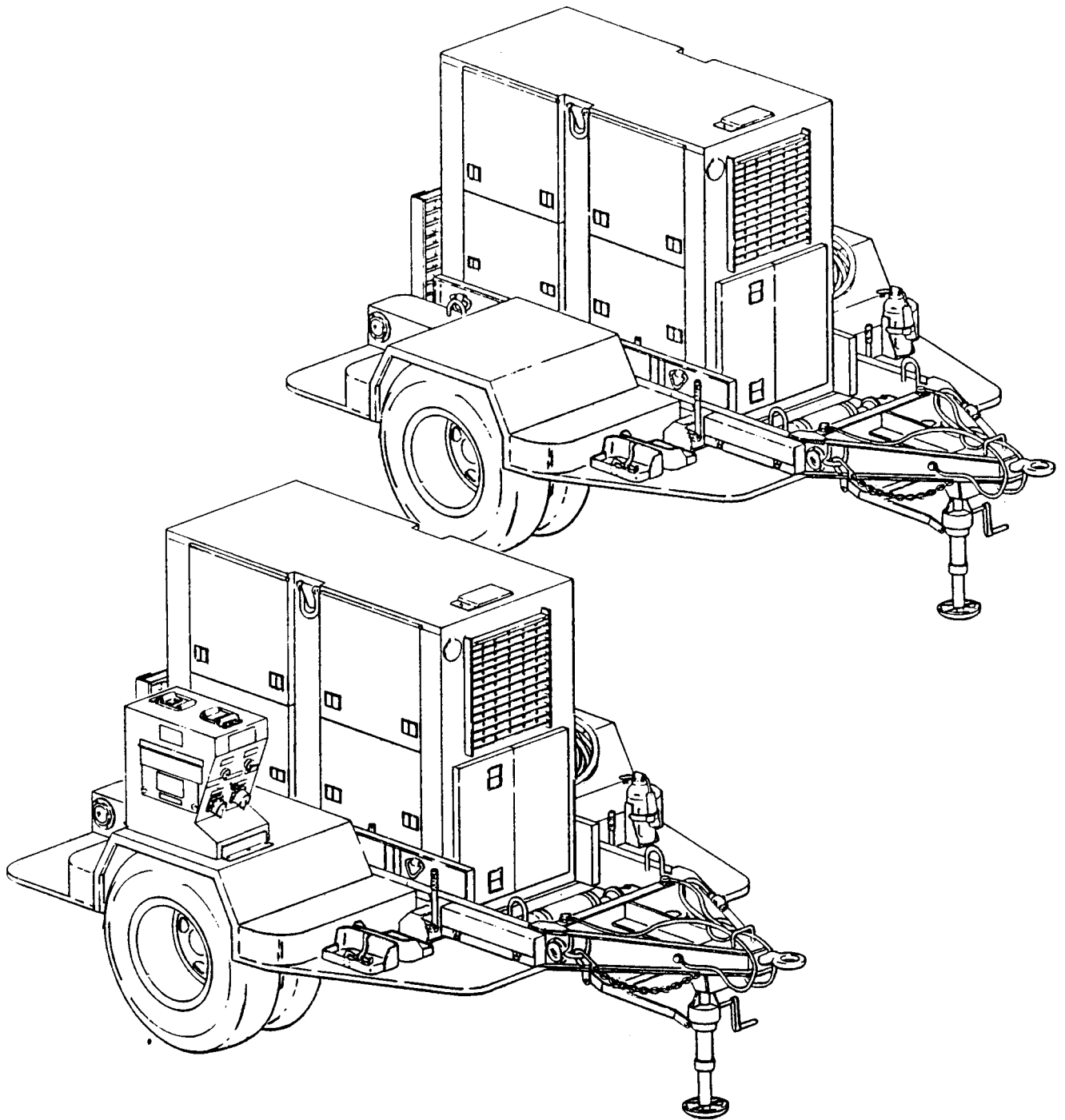

Figure 1-1. Power Plant, Curbside Front, Three-Quarter View.

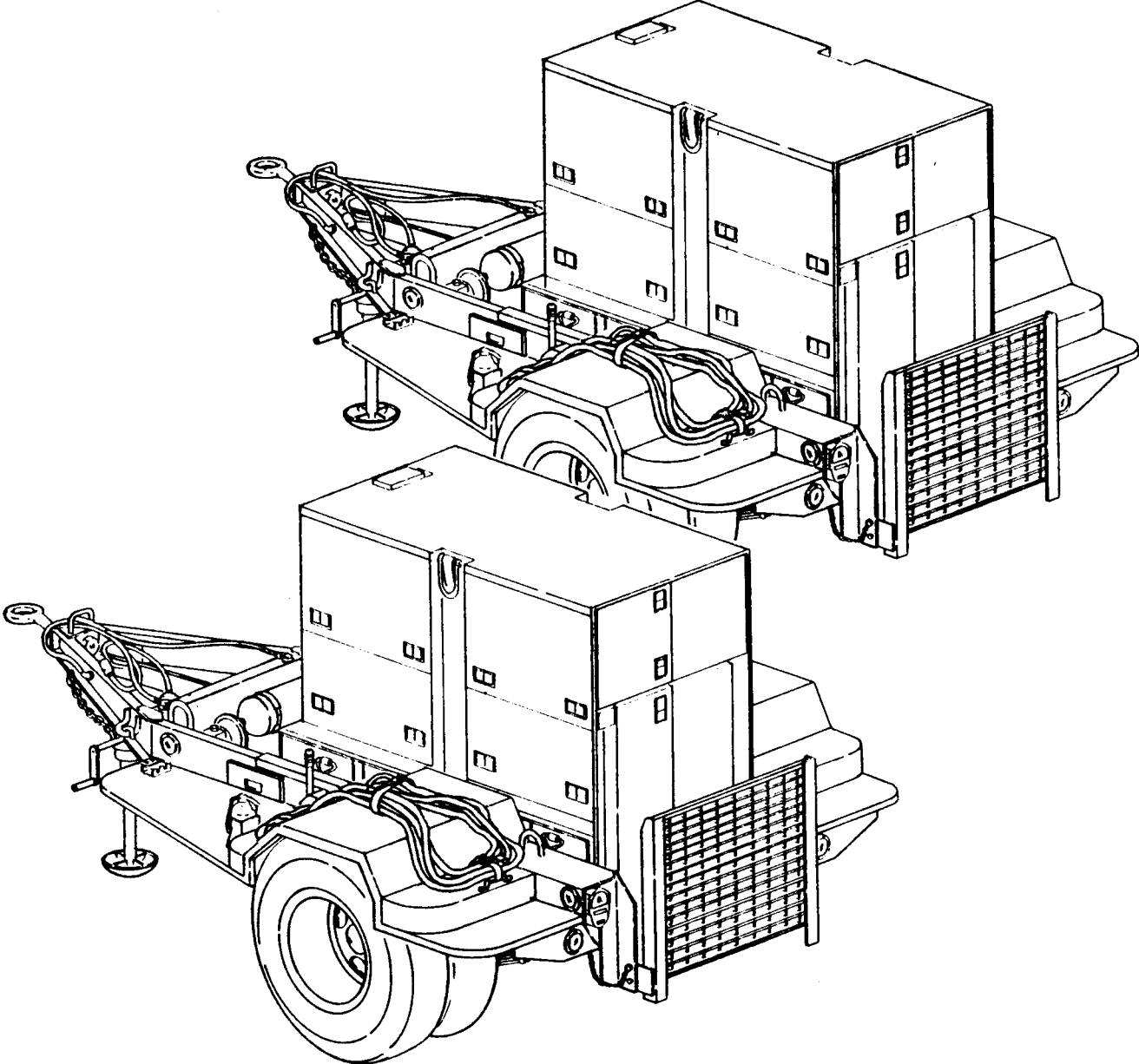

Figure 1-2. Power Plant, Roadside Rear, Three-Quarter View.

(2) *Identification plate.*

(a) *Location.* This plate is located below ground stud above curbside front step.

(b) *Content.*

GROUND TERMINAL

(3) *Wiring diagram designation plate.*

(a) *Location.* This plate is located on switch box rear cover.

(b) *Contents.* (See figure 4-14.)

(4) *Identification plate.*

(a) *Location.* This plate is located on circuit breaker side of switch box.

(b) *Content.*

**SWITCH BOX
ASSEMBLY
PART NO. 97403-13220E6400
SERIAL NO.
NSN 6120-01-090-2789
MANUFACTURER
US**

(5) *Designation plate.*

(a) *Location.* This plate is located on circuit breaker side of switch box above switch S1.

(b) *Content.*

CIRCUIT BREAKER

(6) *Designation plate.*

(a) *Location.* This plate is located on circuit breaker side of switch box above switch S2.

(b) *Content.*

CIRCUIT BREAKER

(7) *Designation plate.*

(a) *Location.* This plate is located on circuit breaker side of switch box below switch S1.

(b) *Content.*

GEN NO. 1

(8) *Designation plate.*

(a) *Location.* This plate is located on circuit breaker side of switch box below switch S2.

(b) *Content.*

GEN NO. 2

(9) *Identification plate.*

(a) *Location.* This plate is located on outside of switch access door.

(b) *Content.*

CIRCUIT BREAKERS

(10) *Identification plate.*

(a) *Location.* This plate is located on outside of power output cover.

(b) *Content.*

POWER OUTPUT

(11) *Instruction plate.*

(a) *Location.* This plate is located on outside of switch access door.

(b) *Content.*

CAUTION

DO NOT TRIP SWITCH UNLESS ALL MAINTENANCE AND OPERATING PERSONNEL ARE CLEAR OF RELATED GENERATOR SET AND OPERATING EQUIPMENT.

(12) *Identification plate.*

(a) *Location.* This plate is located on connector side of switch box above ground stud.

(b) *Content.*

GROUND TERMINAL

(13) *Instruction plate.*

(a) *Location.* This plate is located on power output cover.

(b) *Content.*

**DANGER
HIGH VOLTAGE**

(14) *Designation plate.*

(a) *Location.* This plate is located on load terminal side of switch box above indicator lamp.

(b) *Content.*

**PILOT LIGHT
OUTPUT**

(15) *Designation plate.*

DS1 . (a) *Location.* This plate is located on connector side of switch box above indicator lamp

(b) *Content.*

**PILOT LIGHT
GEN NO. 1
INPUT**

(16) *Designation plate.*

DS2. (a) *Location.* This plate is located on connector side of switch box above indicator lamp

(b) *Content.*

**PILOT LIGHT
GEN NO. 2
INPUT**

(17) *Designation plate.*

(a) *Location.* This plate is located on connector side of switch box above connector J1.

(b) *Content.*

**POWER CABLE
GEN NO. 1
INPUT**

(18) *Designation plate.*

(a) *Location.* This plate is located on connector side of switch box above connector J2.

(b) *Content.*

**POWER CABLE
GEN NO. 2
INPUT**

(19) Designation plate.

(a) *Location.* This plate is located on connector side of switch box above connector J3.

(b) *Content.*

**PARALLEL CABLE
GEN NO. 1
INPUT**

(20) Designation plate.

(a) *Location.* This plate is located on connector side of switch box above connector J4.

(b) *Content.*

**PARALLEL CABLE
GEN NO. 2
INPUT**

(21) Instruction plate.

(a) *Location.* This plate is located on connector side of switch box.

(b) *Content.*

**GENERATOR
POWER INPUT**

b. Tabulated Data for Power Plant.

Overall Length	166 3/8 inches (423.6 centimeters)
Overall Width	95 1/2 inches (242.6 centimeters)
Overall Height	84 inches (213 centimeters)
Net Weight (empty)	11,260 pounds (5106 kilograms)
Net Weight (filled)	11,600 pounds (5261 kilograms)
Shipping Weight	11,620 pounds (5270 kilograms)
Cubage	1,576 cubic feet (45 cubic meters)

1-12. Differences Between Models. There are no differences between models, serial numbers, or serial number groups applicable to this equipment.

CHAPTER 2

OPERATING INSTRUCTIONS

Section I. OPERATING PROCEDURES

2-1. Power Plant Operating Procedures. The typical mission for any mobile power generating equipment can be described in three steps or phases. In the first phase, the power plant is towed to the worksite and installed by unit level technicians (paragraph 4-2). In the second phase of the mission, the operator starts the generator sets, runs them to power a system or equipment, and eventually shuts them down. In the final phase, the power plant is dismantled, packed up and either moved to a new worksite or returned to standby status (paragraph 4-3). This final phase is also accomplished by unit level technicians.

a. Generator Set Operating Procedures.

WARNING

Do not operate power plant generator set(s) until properly grounded (paragraph 4-2, b.) Serious injury or death by electrocution can result from operating an ungrounded generator set.

Operating noise level of generator sets can cause hearing damage. Ear protectors, as recommended by medical or safety officer, must be worn when working near power unit.

CAUTION

To avoid damage to equipment, make certain of voltage, frequency, and phase requirements of load connected to power plant.

NOTE

Before starting generator set, do your Before PMCS as described in table 3-2.

Detailed procedures for prestarting, starting, operating, and shutting down the power plant generator sets are found in TM 5-6115-464-12 and on the Operating Instructions data plates found on the equipment. Refer to the data plate, located inside the right hand control panel door, to start and run the generator sets. Monitor and adjust power output as required during operation. At the end of the mission, shut down the generator sets in accordance with the operating instructions on the data plate.

b. Switch Box Operating Procedures. Start and stop generator sets in accordance with paragraph 2-1, a., when instructed to do so in the following procedures.

CAUTION

Close all doors on generator sets except doors over control panels and louvers.

(1) Alternate operation of power units.

- (a) Set circuit breakers on both power unit generator sets to OFF position.
- (b) Set both switches on switch box to OFF position.
- (c) Start one power unit and bring generator set up to rated speed, voltage, and frequency.
- (d) Set generator set circuit breaker to ON position.
- (e) Set associated switch on switch box to ON position.

NOTE

When the power plant generator set in operation must be shut down, follow steps (f) thru (j) to continue to supply power to system or equipment being powered.

- (f) Start second power unit and bring generator set up to rated speed, voltage, and frequency.
 - (g) Set generator set circuit set breaker to ON position.
 - (h) At switch box, set switch associated with first generator set to OFF position.
 - (i) Set switch box switch associated with second generator set to ON position.
 - (j) Shut down first power plant generator set.
- (2) Parallel operation of power units.

NOTE

Parallel operation of both power plant power units requires prior installation of paralleling cables between each power unit generating set and the switch box. Refer to paragraph 4-2.

- (a) Set circuit breakers on both power plant generator sets to OFF position.
- (b) Set both switches on switch box to OFF position.
- (c) Start one power unit and bring generator set up to rated speed, voltage, and frequency.
- (d) Set SINGLE/PARALLEL switch on operating generator set to PARALLEL position and set circuit breaker to ON.
- (e) Start second, incoming, power unit and bring generator set up to rated speed, voltage, and frequency.
- (f) Set SINGLE/PARALLEL switch on incoming generator set to PARALLEL position.
- (g) Observe SYNCHRONIZING LIGHTS on incoming generator set. Both lights must be going on and off simultaneously.

NOTE

If SYNCHRONIZING LIGHTS are going on and off alternately, generator sets are out of phase. Stop one generator set. Start, and if still out of phase, notify higher level of maintenance.

- (h) Adjust frequency of first, operating, generator set to proper value.
- (i) Adjust frequency of second, incoming, generator set until SYNCHRONIZING LIGHTS go on and off slowly at 2-3 second intervals.

CAUTION

Do not set circuit breaker of second, incoming, generator set to ON position while SYNCHRONIZING LIGHTS are on. Failure to observe this caution could result in damage to one or both generator sets.

- (j) Observe SYNCHRONIZING LIGHTS on incoming generator set. At the instant both lights are out, set circuit breaker to ON position. The two power plant power units are now operating in parallel.
- (k) Readjust VOLTAGE ADJUST rheostats on both power plant generator sets until both AC AMMETERS indicate zero.
- (l) Readjust FREQUENCY ADJUST rheostats on both power plant generator sets until both PERCENT POWER kilowatt meters indicate zero.

NOTE

When load is applied to power plant in step (m), the difference in the kilowatt load between generator sets must not exceed 10%. The difference between current on any phase must not exceed 10%. If necessary, adjust R28 and/or R29 respectively, to correct a kilowatt load or current imbalance.

- (m) Set both switches on switch box to ON position.

CAUTION

Before removing either power unit from parallel operation, make certain the load applied to the power plant through the switch box does not exceed rating of remaining power unit.

- (n) To remove either power unit from parallel operation, set generator set circuit breaker to OFF position.

c. Trailer Operating Procedures. Refer to TM 9-2330-205-14&P for specific operating procedures for the M200A1 trailer.

Section II. OPERATION OF AUXILIARY EQUIPMENT

2-2. Operation of Auxiliary Equipment. There is no auxiliary equipment supplied with the power plant.

Section III. OPERATION UNDER UNUSUAL CONDITIONS

2-3. Operation Under Unusual Conditions. When operating the power unit under unusual conditions such as extremes in temperature or difficult terrain, there are steps that must be taken to protect the equipment.

- a. Refer to TM 5-6115-464-12 for special procedures when operating the generator sets under unusual conditions.
- b. Refer to TM 9-2330-202-14&P for special procedures when operating the trailers under unusual conditions.

CHAPTER 3 OPERATOR/CREW MAINTENANCE INSTRUCTIONS

Section I. CONSUMABLE OPERATING AND MAINTENANCE SUPPLIES

3-1. Consumable Supplies. Consumable supplies used in the maintenance and operation of the power plant are listed in Table 3-1.

Table 3-1. Consumable Operating and Maintenance Supplies.

(1) Component application	(2) National stock number	(3) Description	(4) Qty required for initial operation	(5) Qty required 8 hours operation	(6) Notes
General Cleaning	6850-00-664-5685	Solvent, Drycleaning, P-D-680	1 quart	As required	
Personnel Platform	9150-00-186-6681	Oil, Lubricating, OE/HDO-30	1 quart	As required	
	9150-00-402-4478	Oil, Lubricating, OEA	1 quart	As required	

Section II. LUBRICATION INSTRUCTIONS

3-2. General. Detailed instructions for the lubrication of the major components of the power plant are contained in the applicable Lubrication Orders (LO's). Refer to DA Pam 25-30 to ensure the latest editions of the LO's are used.

3-3. Generator Lubrication. Refer to LO 5-6115-464-12.

3-4. Trailer Lubrication. There are no operator/crew lubrication requirements for the power plant trailers.

Section III. PREVENTIVE MAINTENANCE CHECKS AND SERVICES (PMCS)

NOTE

The PMCS chart in this section contains all necessary Operator/Crew preventive maintenance checks and services for this equipment.

3-5. General. The preventive maintenance checks and services listed in Table 3-2 are grouped according to stages of equipment operation or time intervals. Using the following as a guide, do the checks and services at the intervals shown.

- a. Before you operate, perform your before (B) PMCS. Observe all CAUTIONS and WARNINGS.
- b. While you operate, perform your during (D) PMCS. Observe all CAUTIONS and WARNINGS.
- c. After you operate, be sure to perform your after (A) PMCS.

- d. Do (W) PMCS weekly.
- e. Do (M) PMCS monthly.
- f. If equipment fails to operate, refer to Section IV, Troubleshooting. If the problem cannot be corrected, see paragraph 3-8, Reporting Deficiencies.

3-6. Purpose of PMCS Table. The purpose of the PMCS table is to provide a systematic method of inspecting and servicing the equipment. In this way, small defects can be detected early before they become a major problem causing the equipment to fail to complete its mission. The PMCS table is arranged with the individual PMCS procedures listed in sequence under assigned intervals. The most logical time (before, during, or after operation) to perform each procedure determines the interval to which it is assigned. Make a habit of doing the checks and services in the same order each time and anything wrong will be seen quickly. See paragraph 3-7 for an explanation of the columns in table 3-2.

3-7. Explanation of Columns. The following is a list of the PMCS table column headings with a description of the information found in each column.

a. Item No. This column shows the sequence in which the checks and services are to be performed, and is used to identify the equipment area on the Equipment Inspection and Maintenance Worksheet, DA Form 2404.

b. Interval This column shows when each check is to be done.

c. Item to be Inspected/Procedures. This column identifies the general area or specific part where the check or service is to be done, and the checks or services to be done, and explains how to do them.

d. Equipment is Not Ready/Available If. This column lists conditions that make the equipment unavailable for use because it is unable to perform its mission or because it would represent a safety hazard. Do not accept or operate equipment with a condition in the "Equipment is Not Ready/Available If" column.

3-8. Reporting Deficiencies. If you discover any problem with the equipment during PMCS or while operating it that you are unable to correct, it must be reported. Refer to DA Pam 738-750 and report the deficiency using the proper forms.

3-9. Special Instructions. Preventive maintenance is not limited to performing the checks and services listed in the PMCS table. Covering unused receptacles, stowing unused equipment and other routine procedures such as equipment inventory, cleaning components, and touch-up painting are not listed in the PMCS table. These are things you should do any time you see they need to be done. If a routine check is listed in the PMCS table it is because other operators have reported problems with this item. Take along tools and cleaning cloths needed to perform the required checks and services. Use the information in the following paragraphs to help you identify problems at any time.

a. Routine Inspections. Use the following information to help identify potential problems before and during checks and services.

WARNING

Drycleaning solvent P-D-680 is both toxic and flammable. Wear safety goggles and gloves and use in a well-ventilated area. Avoid prolonged breathing of vapors and avoid skin contact. Do not smoke or use near open flame or excessive heat. Flash point of solvent is 100°F to 138°F (38°C to 59°C). If you become dizzy while using P-D-680, get fresh air immediately and get medical aid. If P-D-680 contacts eyes, flush with water and get medical aid immediately.

- (1) Keep it clean. Dirt, grease, and oil get in the way and may cover up a serious problem. Use drycleaning solvent P-D-680, to clean metal surfaces. Use soap and water to clean rubber or plastic parts and material.
- (2) Bolts, nuts, and screws. Check them all to make sure they're not loose, missing, bent, or broken. Don't try to check them all with a tool, but look for chipped paint, bare metal, or rust around bolt heads. If you find one loose, tighten it or report it to unit maintenance.
- (3) Welds. Look for loose or chipped paint, rust, or gaps where parts are welded together. If a broken weld is found, report it to higher level of maintenance.
- (4) Electrical wires, connectors, terminals and receptacles. Look for cracked or broken insulation, bare wires, and loose or broken connectors. Tighten loose connectors and make sure the wires are in good condition. Examine terminals and receptacles for serviceability.
- (5) Hoses and fluid lines. Look for wear, damage, and leaks. Make sure clamps and fittings are tight. Wet spots and stains around a fitting or connector can mean a leak. If a leak comes from a loose connector, tighten it. If something is broken or worn out, report it to unit maintenance.

b. Leakage Definitions. It is necessary for you to know how fluid leakage affects the status of your equipment. The following are definitions of the types/classes of leakage you need to know to be able to determine the status of your equipment. Learn and be familiar with them. When in doubt, NOTIFY YOUR SUPERVISOR!

Leakage Definitions:

Class I	Seepage of fluid (as indicated by wetness or discoloration) not great enough to form drops.
Class II	Leakage of fluid great enough to form drops but not enough to cause drops to drip from item being checked/inspected.
Class III	Leakage of fluid great enough to form drops that fall from the item being checked/inspected.

CAUTION

Equipment operation is allowable with minor leakage (Class I or II) of any fluid except fuel. Of course, consideration must be given to the fluid capacity in the item being checked/inspected. When in doubt, notify your supervisor.

When operating with Class I or II leaks, continue to check fluid level more often than required in the PMCS. Parts without fluid will stop working and/or cause equipment damage.

Class III leaks should be reported to your supervisor or unit maintenance.

Table 3-2. Operator/Crew Preventive Maintenance Checks and Services (PMCS)

NOTE

If the equipment must be kept in continuous operation, check and service only those items that can be checked and serviced without disturbing operation. Make the complete checks and services when the equipment can be shut down.

Within designated interval, these checks are to be performed in the order listed.

B - Before D - During A - After W - Weekly M - Monthly

Item no.	Interval					Item to be inspected. Procedure: check for and have repaired, filled, or adjusted as needed	Equipment is not ready/available if:
	B	D	A	W	M		
						<p><u>WARNING</u></p> <p>Before performing any maintenance that requires climbing on or under trailer, set trailer handbrakes, chock wheels, and lower rear leveling jacks. Injury to personnel could result from trailer suddenly rolling or tipping.</p>	

Table 3-2. Operator/Crew Preventive Maintenance Checks and Services (PMCS) – CONT.

B - Before D - During A - After W - Weekly M - Monthly

Item no.	Interval					Item to be inspected. Procedure: check for and have repaired, filled, or adjusted as needed	Equipment is not ready/available if:
	B	D	A	W	M		
						NOTE	
						<p>This PMCS table lists the checks and services as performed on a single power unit. These procedures must be duplicated on each of the two power units that make up the AN/MJQ-15.</p> <p>Perform weekly as well as before PMCS if:</p> <p>You are the assigned operator but have not operated the equipment since the last weekly inspection.</p> <p>You are operating the equipment for the first time.</p>	
1	●					<p>GENERATOR SET EXTERIOR</p> <p>a. Check on, around, and beneath generator set for fuel or oil and coolant leaks.</p> <p>b. Check that generator set ground is properly installed and grounding connections are tight.</p> <p>c. Manually open and close radiator louver doors to check for proper operation.</p>	<p>A Class III coolant or lubrication oil leak or any class fuel leak is detected.</p> <p>Not properly grounded.</p>
2	●	●	●			<p>FUEL GAGE</p> <p>Check fuel gage (1) for sufficient fuel for continuous operation.</p>	

Table 3-2. Operator/Crew Preventive Maintenance Checks and Services (PMCS) - CONT.

B - Before D - During A - After W - Weekly M - Monthly

Item no.	Interval					Item to be inspected. Procedure: check for and have repaired, filled, or adjusted as needed	Equipment is not ready/available if:
	B	D	A	W	M		
2	●	●	●			<p>FUEL GAGE – CONT</p>  <p>FUEL LEVEL</p>	
3	●					<p>ENGINE OIL LEVEL</p> <p>Check oil filler dipstick (2) for proper oil level. Add oil as required.</p> 	
4	●					<p>ACCESSORIES</p> <p>Check that the following accessories are not missing.</p> <p>a. Sledge hammer</p>	

Table 3-2. Operator/Crew Preventive Maintenance Checks and Services (PMCS) – CONT.

Item no.	Interval					Item to be inspected. Procedure: check for and have repaired, filled, or adjusted as needed	Equipment is not ready/available if:
	B	D	A	W	M		
4	●					<p>ACCESSORIES - CONT</p> <p>b. Fire extinguisher</p> <p>c. Driver/puller</p> <p>d. Ground rods</p>	<p>Fire extinguishers are missing.</p> <p>Ground rods are missing.</p>
5	●					<p>BRACKETS</p> <p>Check fire extinguisher and fuel can mounting brackets for loose hardware and broken fittings.</p>	
6	●					<p>TIRES</p> <p>a. Check for cuts, foreign objects or unusual tread wear. Remove any stones from between the treads.</p> <p>b. Check that tire pressure is 35 psi (241 .22 kPa) when tires are cool.</p>	<p>One tire is flat, missing or unserviceable.</p>
7	●					<p>WHEELS</p> <p>Check for wheel damage and for loose or missing stud nuts (3).</p> 	<p>One wheel is damaged. One stud nut is loose or missing.</p>

Table 3-2. Operator/Crew Preventive Maintenance Checks and Services (PMCS) - CONT.

B - Before D - During A - After W - Weekly M - Monthly

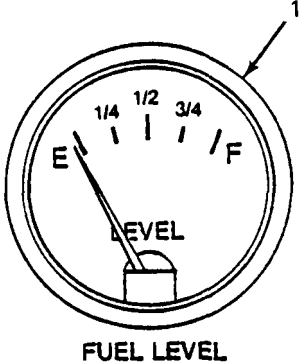
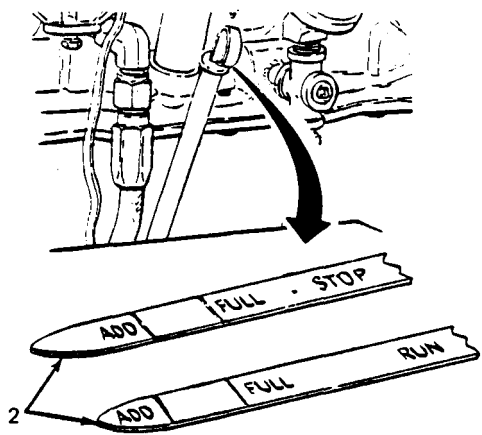
Item no.	Interval					Item to be inspected. Procedure: check for and have repaired, filled, or adjusted as needed	Equipment is not ready/available if:
	B	D	A	W	M		
8	●					LUNETTE Check lunette (4) for insecure mounting and obvious damage.	Lunette is loose or bent.
9	●					INTERVEHICULAR CABLE Check cable (5) and connector for cuts and breaks.	Intervehicular cable is broken or missing.
10	●					SAFETY CHAINS Check safety chains (6) for insecure mounting and obvious damage.	Safety chains are missing or unsecured.
11	●					AIR HOSES, FITTINGS AND BRAKE AIR CHAMBER Check air hoses (7), fittings (8) and brake air chamber (9) for signs of damage or leaks.	Damage or leaks are detected.

Table 3-2. Operator/Crew Preventive Maintenance Checks and Services (PMCS) - CONT.

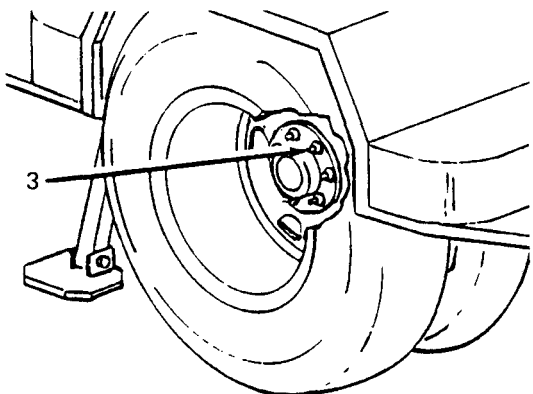
B - Before

D - During

A - After

W - Weekly

M - Monthly

Item no.	Interval					Item to be inspected. Procedure: check for and have repaired, filled, or adjusted as needed	Equipment is not ready/available if:
	B	D	A	W	M		
11	●					<p>AIR HOSES, FITTINGS AND BRAKE AIR CHAMBER - CONT</p> 	
12	●					<p>HYDRAULIC HOSES, FITTINGS AND MASTER CYLINDER</p> <p>Check brake system hoses (10) and fittings (11) and master cylinder (12), and check under vehicle for signs of brake fluid leaks.</p> 	<p>A class III brake fluid leak is detected.</p>

Table 3-2. Operator/Crew Preventive Maintenance Checks and Services(PMCS) - CONT.

B - Before

D - During

A - After

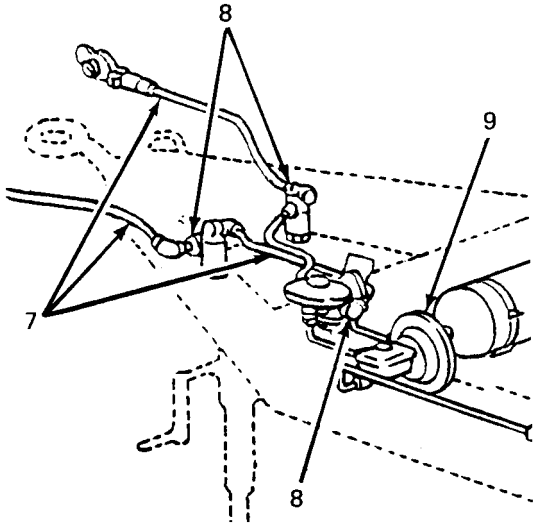
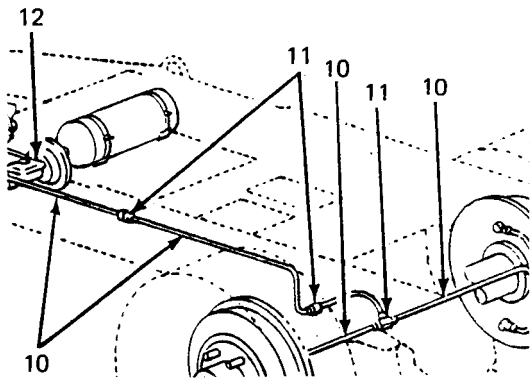
W - Weekly

M - Monthly

Item no.	Interval					Item to be inspected. Procedure: check for and have repaired, filled, or adjusted as needed	Equipment is not ready/available if:
	B	D	A	W	M		
13		•				<p>LANDING LEG</p> <p>Check condition of landing leg (13).</p> 	There is indication that leg might collapse.
14		•				<p>LEVELING JACK</p> <p>Check condition of leveling jack (14).</p> 	There is indication that a jack might collapse.

Table 3-2. Operator/Crew Preventive Maintenance Checks and Services (PMCS) - CONT.

B - Before D - During A - After W - Weekly M - Monthly

Item no.	Interval					Item to be inspected. Procedure: check for and have repaired, filled, or adjusted as needed	Equipment is not ready/available if:
	B	D	A	W	M		
15		●				<p>LIGHTS</p> <p>a. With intervehicular cable connected to towing vehicle, operate vehicle light switch through all settings and check lights (15).</p> <p style="text-align: center;">NOTE</p> <p style="text-align: center;">An assistant is required while checking brake lights.</p> <p>b. Step on brake pedal and check brake lights (15).</p> 	
16		●				<p>BRAKE SYSTEM</p> <p>Test brake system by hooking trailer to towing vehicle and applying brakes.</p>	Service brakes fail to operate.
17		●				<p>TRAILER OPERATION</p> <p>a. Be alert for any unusual noises while towing trailer. Stop and investigate any unusual noises.</p>	

Table 3-2. Operator/Crew Preventive Maintenance Checks and Services (PMCS) - CONT.

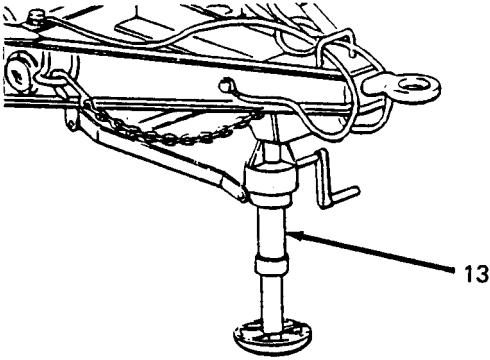
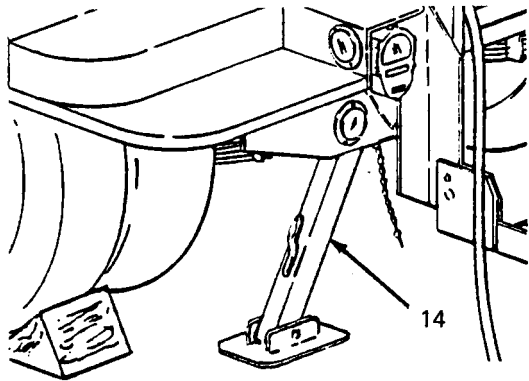
Item No.	Interval					Item to be Inspected. Procedure: check for and have repaired, filled, or filled, or adjusted as needed	Equipment is not ready/available if:
	B	D	A	W	M		
17		•				TRAILER OPERATION - CONT	
18		•				<p>GENERATOR SET GAGES AND INSTRUMENTS</p> <p>a. Check that air cleaner condition indicator (16) does not indicate a clogged air cleaner. Press-to-test.</p> <p>b. Check that battery charging ammeter (17) is in green area during normal operation.</p>  <p>c. Check that frequency meter (18) indicates 400 Hz (red line) when generator is operating under load.</p> <p>d. Check that kilowatt meter (19) reading does not exceed 100%.</p>	<p>Light remains on during operation.</p> <p>Battery indicator not in green area.</p> <p>Correct frequency cannot be maintained.</p>

Table 3-2. Operator/Crew Preventive Maintenance Checks and Services (PMCS) - CONT.

B - Before

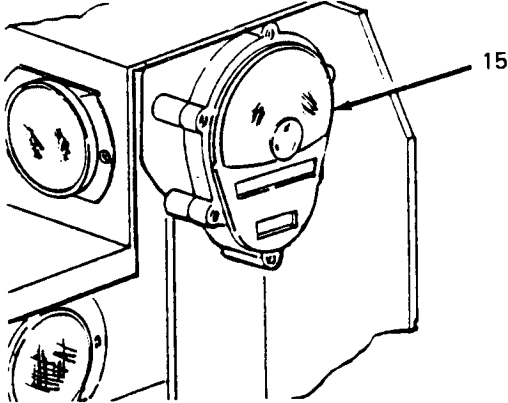
D - During

A - After

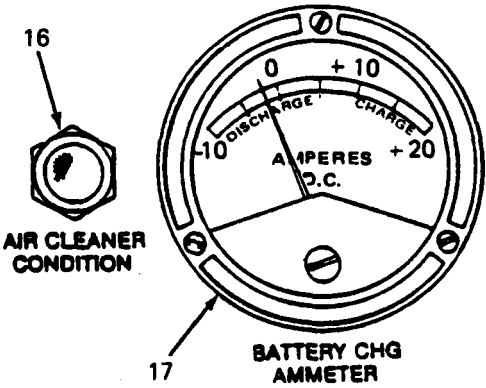
W - Weekly

M - Monthly

Item no.	Interval					Item to be inspected. Procedure: check for and have repaired, filled, or adjusted as needed	Equipment is not ready/available if:
	B	D	A	W	M		
18						<p>GENERATOR SET GAGES AND INSTRUMENTS - CONT</p>  <p>e. Check that A.C. ammeter (20) reading does not exceed 100% of rated current or more than 5% load difference between phases.</p> <p>f. Check that A.C. voltmeter (21) indicates desired output voltage as determined by load connections and amps-volts selector switch.</p> <p>g. Check engine oil pressure gage (22) for 30 to 55 psig indication.</p>	<p>No indication when load is applied.</p> <p>Desired voltage cannot be obtained and maintained.</p> <p>Oil pressure drops below 30 psig.</p>

Table 3-2. Operator/Crew Preventive Maintenance Checks and Services (PMCS) - CONT.

B - Before

D - During

A - After

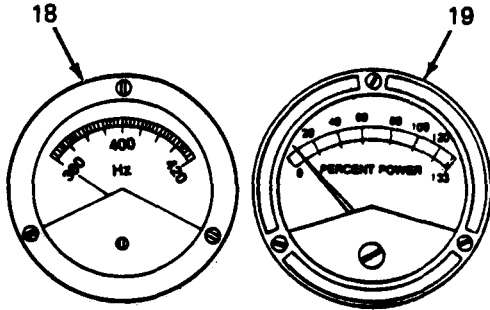
W - Weekly

M - Monthly

Item no.	Interval					Item to be inspected. Procedure: check for and have repaired, filled, or adjusted as needed	Equipment is not ready/available if:
	B	D	A	W	M		
18						<p>GENERATOR SET GAGES AND INSTRUMENTS - CONT</p> <p>h. Check coolant temperature gage (23) for 170° to 200°F (76.7° to 93.3°C) indication.</p> <p>i. Check that all lights on fault indicator panel (24) are out during operation. Check bulb operation with TEST or RESET switch on panel.</p>	<p>Temperature exceeds 200°F (93.3°C).</p> <p>Fault light will not go out when switch is set to TEST or RESET position, then released, All bulbs should be lit when switch is in TEST or RESET position.</p>

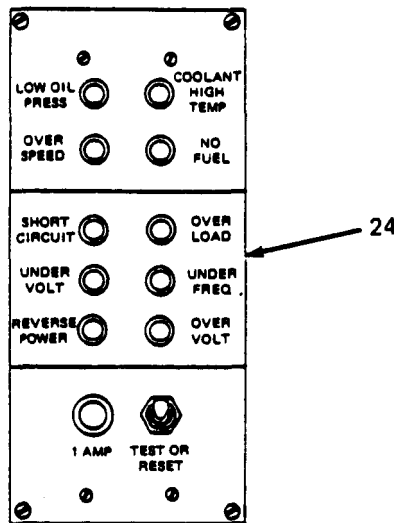

Table 3-2. Operator/Crew Preventive Maintenance Checks and Services (PMCS) – CONT.

Item no.	Interval					Item to be inspected. Procedure: check for and have repaired, filled, or adjusted as needed	Equipment is not ready/available if:
	B	D	A	W	M		
19	●					<p>FUEL TANK</p> <p>a. Fill tank (25) upon completion of operation.</p> <p style="text-align: center;">NOTE</p> <p>Fuel system temperature must be above freezing when draining water and sediment.</p> <p>b. Open drain (26) and drain water and sediment from fuel tank. Allow to drain until fuel runs clean.</p> 	
20	●					<p>FUEL STRAINER AND FILTERS</p> <p>Drain water and sediment from strainer (27), primary (28) and secondary (29) filters. Allow to drain until fuel runs clean.</p>	

Table 3-2. Operator/Crew Preventive Maintenance Checks and Services (PMCS) – CONT.

B - Before

D - During

A - After

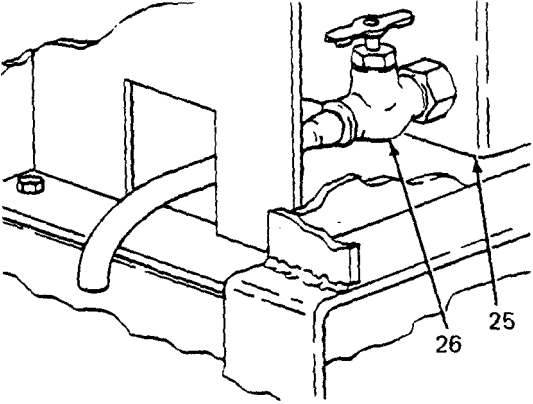
W - Weekly

M - Monthly

Item no.	Interval					Item to be inspected. Procedure: check for and have repaired, filled, or adjusted as needed	Equipment is not ready/available if:
	B	D	A	W	M		
20	●					<p>FUEL STRAINER AND FILTERS - CONT</p> 	
21			●			<p>BATTLE SHORT INDICATOR LIGHT</p> <p>Push in on lens housing. Light (30) should illuminate. If not, replace bulb.</p>	
22			●			<p>CIRCUIT BREAKER INDICATOR LIGHT</p> <p>Push in on lens housing. Light (31) should illuminate. If not, replace bulb.</p> 	

Table 3-2. Operator/Crew Preventive Maintenance Checks and Services (PMCS) – CONT.

B - Before D - During A - After W - Weekly M - Monthly

Item no.	Interval					Item to be inspected. Procedure: check for and have repaired, filled, or adjusted as needed	Equipment is not ready/available if:
	B	D	A	W	M		
23			●			<p>BRAKE DRUMS AND HUBS</p> <p><u>WARNING</u></p> <p>A defect in the operation of the brake or hub can cause these parts to get hot enough to cause serious burns. Use extreme caution when attempting to detect heat in this area.</p> <p>Feel drums and hubs for overheating to detect dragging or binding.</p>	Brakes or hub are dragging or binding.
24			●			<p>AIR RESERVOIR</p> <p>Open draincock (32) to drain moisture from air reservoir (33) and close when finished.</p> 	
25			●			<p>HANDBRAKES</p> <p>With trailer hooked to towing vehicle, set handbrakes (34). Move trailer slightly to see if handbrakes hold wheels. Adjust as required.</p>	

Table 3-2. Operator/Crew Preventive Maintenance Checks and Services (PMCS) - CONT.

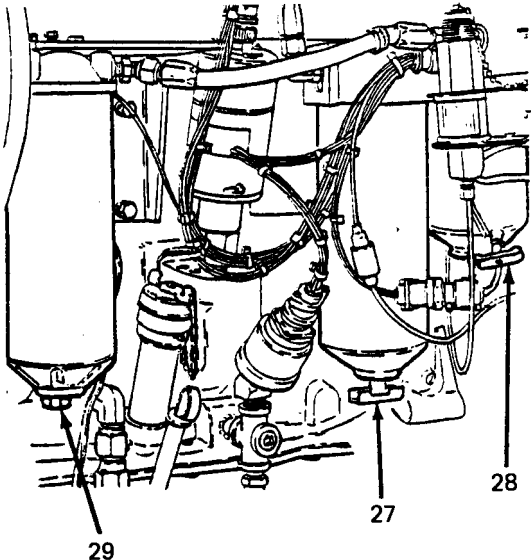
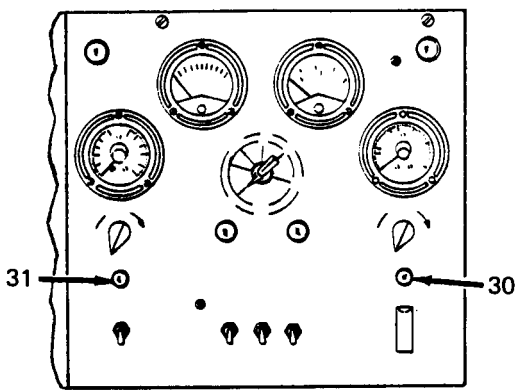
B - Before

D - During

A - After

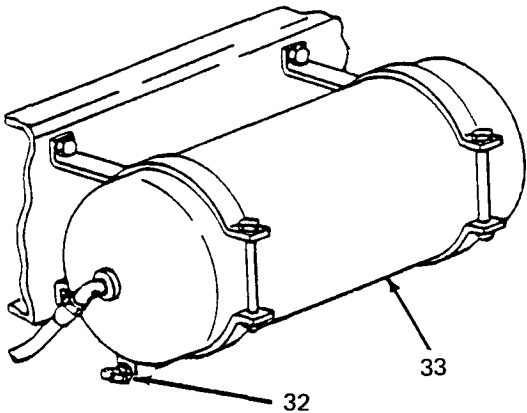
W - Weekly

M - Monthly

Item no.	Interval					Item to be inspected. Procedure: check for and have repaired, filled, or adjusted as needed	Equipment is not ready/available if:
	B	D	A	W	M		
25			●			<p>HANDBRAKES - CONT</p> 	
26			●			<p>REFLECTORS</p> <p>Check for damaged or missing reflectors.</p>	
27			●			<p>BATTERIES</p> <p>Check battery (35) electrolyte level. Level should be about 3/4 inch above top of plates. Add water if level is low. Use clean water (distilled water if available).</p> 	

Table 3-2. Operator/Crew Preventive Maintenance Checks and Services (PMCS) – CONT.

B - Before D - During A - After W - Weekly M - Monthly

Item No.	Interval					Item to be inspected. Procedure: check for and have repaired, filled, or adjusted as needed	Equipment is not ready/available if:
	B	D	A	W	M		
28					•	FIRE EXTINGUISHER Inspect and weigh fire extinguisher. (See paragraph 3-11.)	Frame is obviously broken or cracked.
29					•	TRAILER FRAME Inspect entire chassis frame for damage, cracks, and broken welds.	
30	•					COLLANT LEVEL Check level of fluid in cooling system. Proper level is 2 inches below overflow pipe. Add coolant as required.	

Section IV. TROUBLESHOOTING

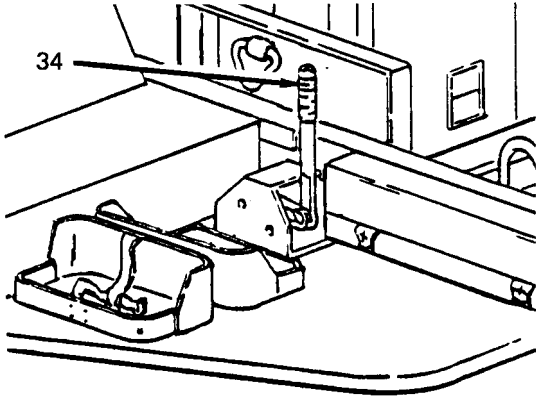
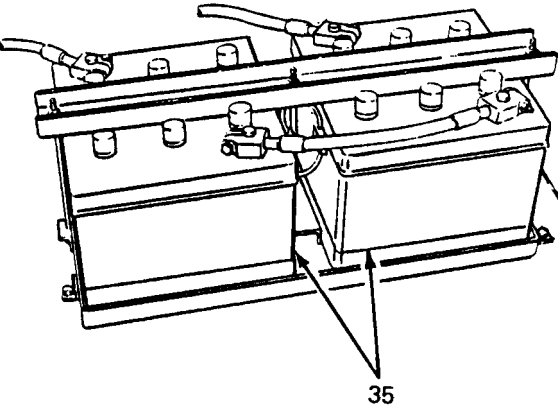
3-10. Power Plant Troubleshooting. There are no troubleshooting procedures authorized at operator level for the power plant end item. Troubleshooting procedures for the individual generator sets and trailers are contained in their respective technical manuals referenced below.

a. *Generator Set Troubleshooting.* Refer to TM 5-6115-464-12 for, troubleshooting procedures applicable to the generator set.

b. *Trailer Troubleshooting.* Refer to TM 9-2330-205-14&P for troubleshooting procedures applicable to the trailer.

Section V. OPERATOR/CREW MAINTENANCE

3-11. Fire Extinguisher Maintenance. The AN/MJQ-15 Power Plant is equipped with two 5 lb CO₂ fire extinguishers. Maintenance is limited to weighing the fire extinguishers monthly to insure that they are sufficiently charged. Fully charged, each extinguisher weighs 13 lbs. Send the unit to specialized activity for recharging if it weighs 12.5 lb or less.

CAUTION

Do not attempt to verify readiness of a fire extinguisher by partially discharging unit. Any discharge of contents will require refilling.

CHAPTER 4

UNIT MAINTENANCE

Section I. SERVICE UPON RECEIPT OF EQUIPMENT

4-1. Inspecting and Servicing Equipment. The power plant is unpacked, inspected, and serviced as described in the following paragraphs. Unpacked equipment must be checked against the Equipment Packing List to ensure completeness. Discrepancies must be reported in accordance with instructions in DA Pam 738-750.

a. Unpacking Power Plant. (See figures 4-1 and 4-2.) The two power units that make up the AN/MJQ-15 power plant are identical except for the addition of the switch box installed on the curbside fender of one of the units. Therefore, the unpacking procedures are typical for both. Each generator set is packed in place on its respective trailer. Before beginning the unpacking procedure, locate and remove Depreservation Guide.

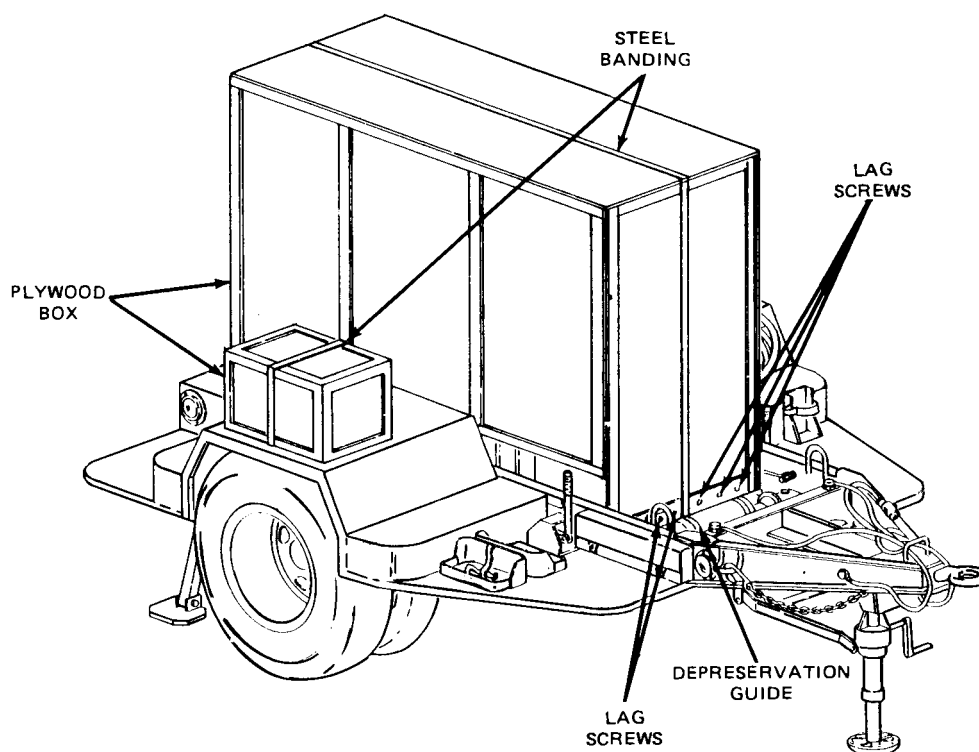

Figure 4-1. Power Unit B, with Switch Box, Packed for Shipment.

WARNING

The steel banding used in packaging of power plant has sharp edges. Care should be taken when cutting and handling banding to avoid injury to personnel.

- (1) Remove steel banding around plywood box(es) covering generator set and, when unpacking unit B, the switch box.

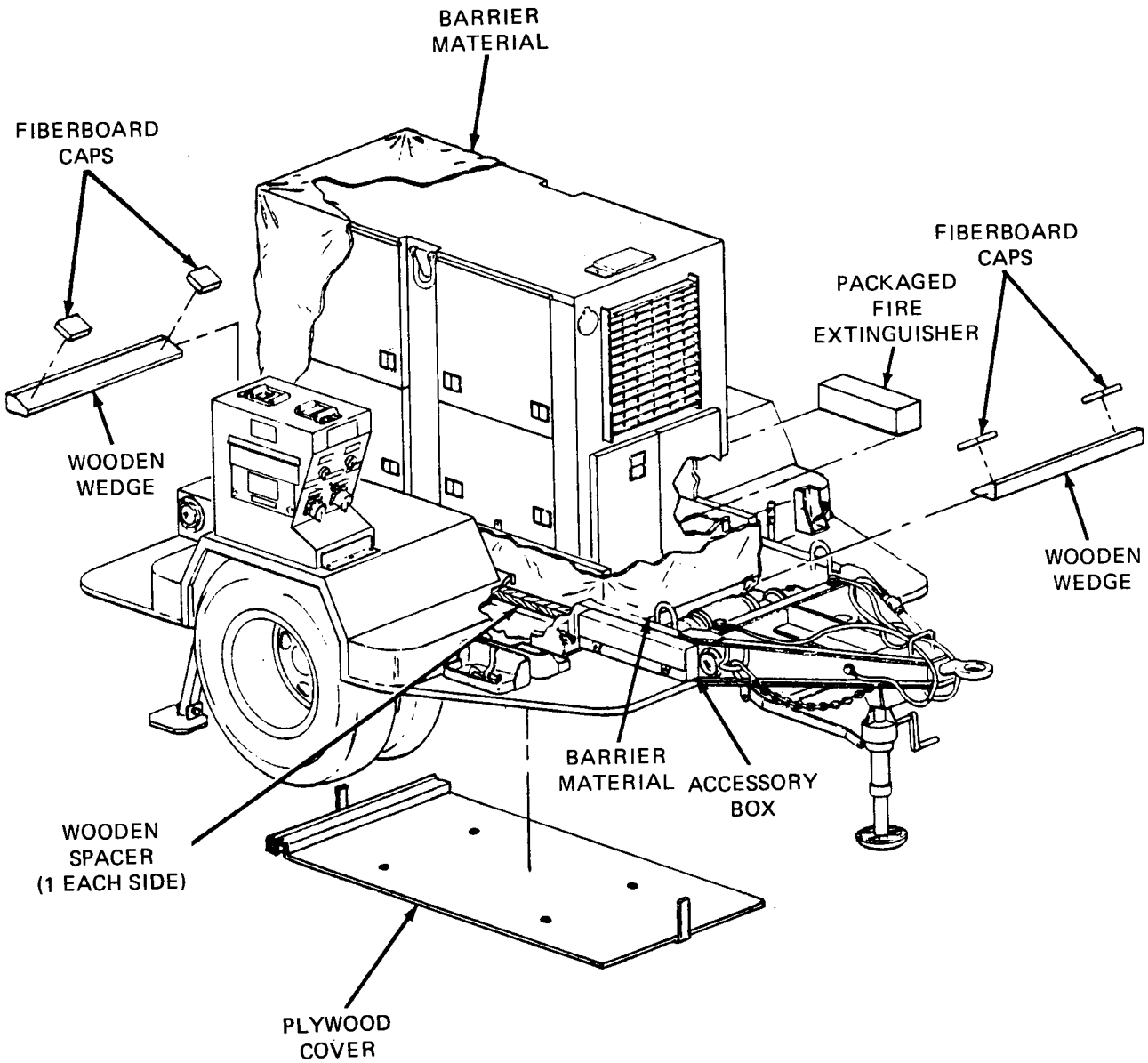

Figure 4-2. Unpacking Power Plant - Power Unit B Shown.

- (2) Remove lag screws securing plywood box cover over generator set and lift off cover.
- (3) Remove wooden wedges and spacers from around generator set base. Loosen switch box attaching hardware and remove any steel banding remaining beneath switch box.
- (4) Remove and save package of technical manuals secured to barrier material.
- (5) Remove four sets of attaching hardware and drop plywood cover under trailer.
- (6) Remove barrier material and fiberboard caps from generator set.
- (7) Remove packaged fire extinguisher from within generator set enclosure. Unpack and secure fire extinguisher in bracket on front roadside step.
- (8) Remove steel banding around accessory box, unpack and inventory contents.
- (9) Refer to DA Form 2258, Depreservation Guide for Vehicles and Equipment, packed with power unit and follow instructions given for putting unit into service.
- (10) Stow technical manuals in box on inside of generator set enclosure rear curbside door.
- (11) Stow all authorized accessories in the accessory box.
- (12) Remove all tape and packing film from trailer air hoses and intervehicular cable.

b. Inspection and Servicing of Generator Set. Refer to Servicing Upon Receipt of Materiel in TM 5-6115-464-12 for initial inspection and servicing procedures.

c. Inspection and Servicing of Trailers. Refer to Servicing Upon Receipt of Materiel in TM 9-2330-205-14&P for initial inspection and servicing procedures.

4-2. Installation. (See figure 4-3.) Installation of the power plant at a worksite involves positioning both the power unit trailers and the switch box, and grounding the equipment.

a. Positioning Power Plant. Position the power plant on the worksite as follows:

- (1) Select an area as level as possible to install power plant and position both power units.
- (2) Set handbrakes and lower landing legs on both trailers.
- (3) Chock both sets of dual wheels on each trailer.
- (4) Lower both rear leveling jacks on each trailer and secure leveling jacks with lockpins. Extend lower tubes on leveling jacks by stepping on hinged pads.

WARNING

Remove fire extinguishers and fuel cans from individual power units when power plant is in operation. This will insure that in the event of fire, extra fuel will not be involved and extinguishers will remain accessible.

- (5) Locate fuel cans and fire extinguishers on ground halfway between the two power units.

- (6) Remove switch box from fender of power unit B and stow attaching hardware in accessory box.
- (7) Position switch box assembly on ground halfway between two power units.
- (8) Unstrap and remove power cables from fenders of both power units.

NOTE

When performing step 10, note that the power cables, the individual wires in the cables, and the generator set load terminals are all marked for identification. Make certain these markings correspond when connecting power cables.

- (9) Connect power cable to each generator set load terminal board as follows:
 - (a) White wire to load terminal L0.
 - (b) Black wire to load terminal L1.
 - (c) Red wire to load terminal L2.
 - (d) Blue wire to load terminal L3.
- (10) Connect both power cables to switch box.
- (11) When power plant power units are to be operated in parallel, install paralleling cables between generator sets and switchbox.

WARNING

Do not operate power plant until both power units have been properly grounded (paragraph 4-2, b.) Serious injury or death by electrocution can result from operating an ungrounded power plant.

CAUTION

To avoid damage to equipment, make certain of voltage, frequency, and phase requirements of load being connected to power plant.

NOTE

The following information is applicable when AN/MJQ-15 Power Plant is used with the TAC-FIRE System. Remove wire No, X13B4N from generator load connection L0 and ground stud E6 (generator skid base grounding stud). This wire must be replaced when the generator set is turned back into supply system.

- (12) Connect power plant switch box to system or equipment to be powered. Refer to TM 5-6115-464-12.
- (13) Remove quick-release pins securing both power unit personnel platforms and lower platforms.

- (14) On both power units, open control panel doors and the two doors immediately below the control panels.

b. Grounding. Check that the individual power unit generator sets are grounded to the GROUND TERMINAL studs on their respective trailer frames. Using ground wire supplied with power plant, connect GROUND TERMINAL lug on switch box to a suitable ground as described below. The following sources of a good ground are listed in order of preference.

NOTE

As a substitute for the supplied ground wire, any copper wire of at least No. 6 AWG may be used.

(1) *Underground water system.* Ground power plant to one of the accessible pipes in an underground water system. Make certain underground pipe is made of metal and there is no insulation, such as a water meter, between ground wire and the earth.

(2) *Ground rod.* Drive grounding rod a minimum of eight feet into earth. A ground rod must have a minimum diameter of 5/8-inch, if solid, or 3/4-inch if pipe.

NOTE

It maybe necessary to saturate the area around ground rod with water if soil conditions are dry.

(3) *Ground plate.* Ground power plant to a metal plate buried four feet deep. Ground plate should cover a minimum area of nine square feet.

c. External Fuel Line Connection. (See figure 4-4.) Either or both of the power units that make up the power plant can be fueled from an external source. The external source could be a five-gallon fuel can or a 55-gallon drum. This eliminates the need for frequent refilling of a generator set's fuel tank during long intervals of operation.

- (1) Remove fuel can adapter and fuel pickup tube from storage locations on power unit and assemble by threading pickup tube into adapter.
- (2) Thread one end of auxiliary fuel line onto fuel can adapter fitting and tighten.
- (3) Connect free end of auxiliary fuel line to AUXILIARY FUEL CONNECTION. This connection is located next to the fuel filler above the trailer roadside fender.
- (4) Insert fuel can adapter into external fuel source and secure by pressing down on lever.
- (5) Set FUEL SELECTOR VALVE beneath fuel filler to AUXILIARY position.

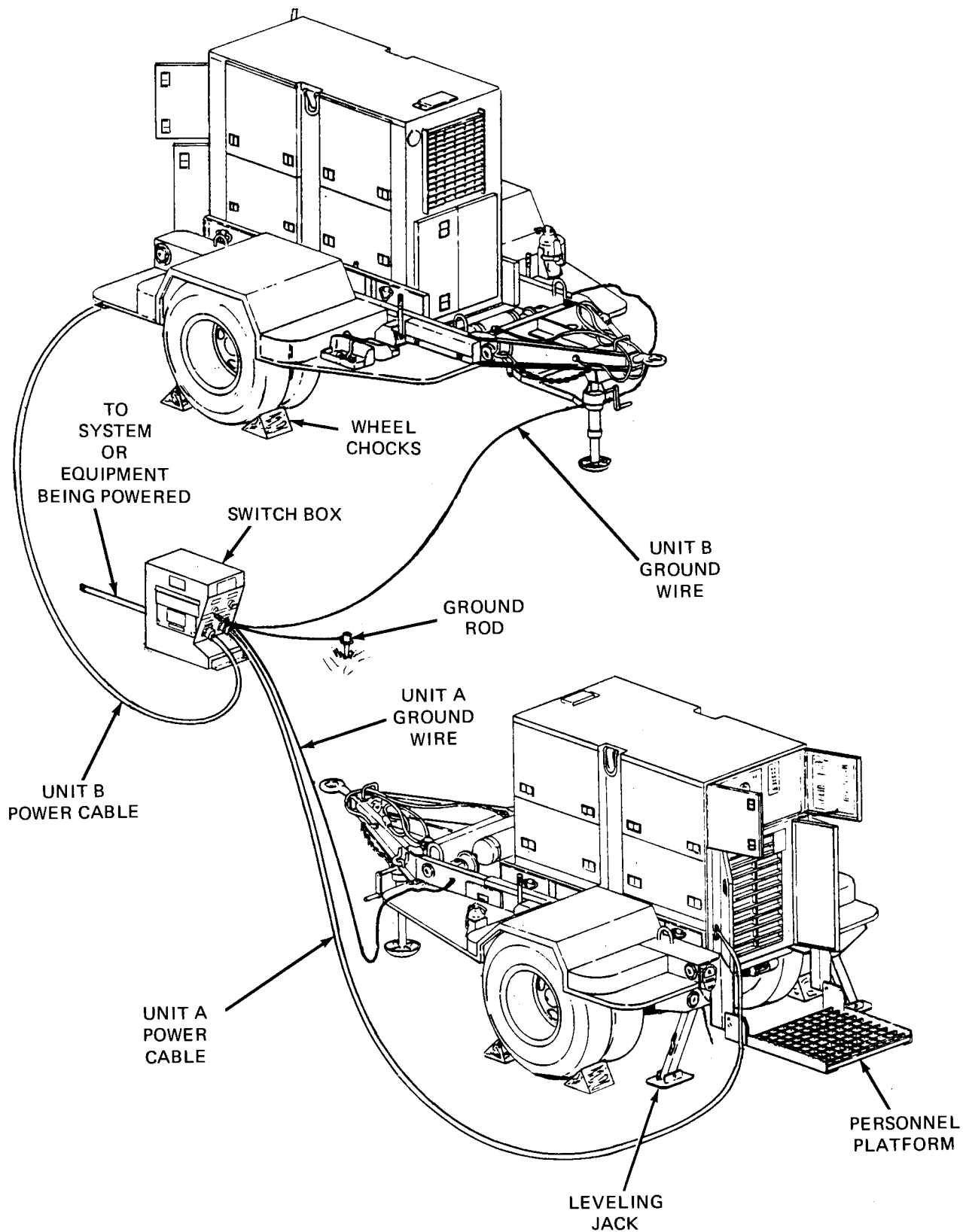

Figure 4-3. Power Plant Installation.

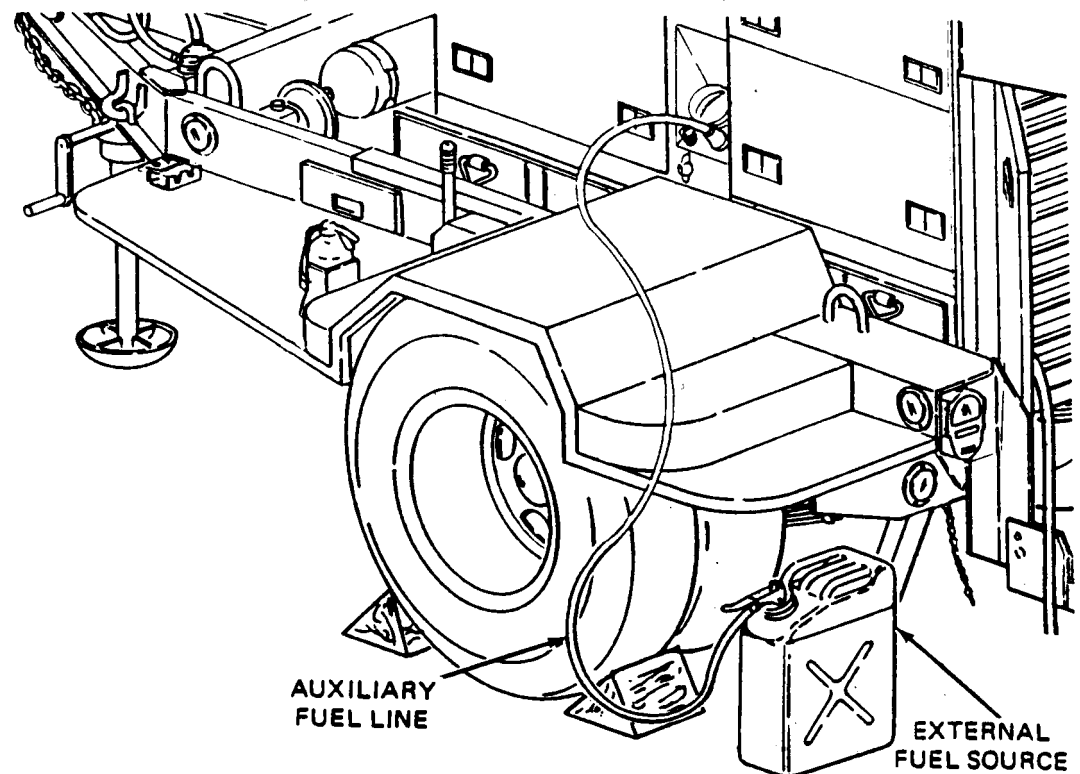

Figure 4-4. External Fuel Line Connection.

Section II. MOVEMENT TO A NEW WORKSITE

4-3. Dismantling for Movement. Because the power plant is designed to be mobile, a minimum amount of effort is required to relocate to a new worksite. Procedures are as follows:

- a. Shut down generator set and position switches in off position. ■
- a1. Disconnect power plant from system or equipment being powered.
- b. Disconnect ground cables between switch box and GROUND TERMINAL studs on both power units. Roll up cables and store in accessory boxes. ■
- c. Using slide hammer, remove ground rods. Disassemble, clean, and stow ground rods in accessory boxes.
- d. Disconnect power plant from external fuel sources, if applicable.
- e. Disconnect ground wires between switch box and GROUND rod. Roll up ground wires and store in accessory boxes. ■
- f. Disconnect power cables from both power units and from switch box. Roll up cables and secure each to roadside fender of respective power unit using straps provided.
- g. Close switch box access door and cap connectors. Position switch box on curbside fender of power unit B and secure with hardware provided.

- h. Stow any remaining authorized equipment in accessory box.
- i. Secure fire extinguishers and fuel cans in their respective mounting brackets.
- j. Close all doors on the generator set enclosures.
- k. On each power unit, swing personnel platform up into traveling position and secure with two platform anchor quick-release pins.

WARNING

Use care when releasing spring-loaded lower tube of leveling jacks. The lower tube will return to retracted position with considerable force and can cause injury.

- l. Retract lower tubes of leveling jacks. Swing leveling jacks up, into traveling position and secure with lockpins.
- m. Remove wheel chocks.
- n. Attach power units to towing vehicles. Refer to TM9-2330-205-14&P.
- o. Release trailer handbrakes on both power units.

4-4. Reinstallation After Movement. After movement to a new worksite, install power plant in accordance with paragraph 4-2.

Section III. REPAIR PARTS, SPECIAL TOOLS, SPECIAL TEST, MEASUREMENT AND DIAGNOSTIC EQUIPMENT (TMDE)

4-5. Tools and Equipment. There are no special tools or equipment required to maintain the AN/MJQ-15 power plant.

4-6. Maintenance Repair Parts. Repair parts and equipment for maintenance of this power plant are listed and illustrated in the repair parts and special tools list in Appendix D of this manual.

Section IV. LUBRICATION INSTRUCTIONS

4-7. General. Detailed instructions for the lubrication of the major components of the power plant are contained in the applicable Lubrication Orders (LO's). Refer to DA Pam 25-30 to ensure that the latest editions of the L.O.'S are used. This section contains lubrication instructions that are not included in the Lubrication Orders.

4-8. Generator Lubrication. Refer to LO 5-6115-464-12 for generator set Lubrication Order.

4-9. Trailer Assembly Lubrication.

a. Trailer Lubrication. Refer to TM 9-2330-205-14&P for trailer Lubrication Order.

b. Personnel Platform Lubrication. The personnel platform is a modification to the standard M200A1 trailer and, as such, does not appear in the associated L.O. Lubricate the personnel platform semiannually as follows:

WARNING

Clean parts in a well-ventilated area. Avoid inhalation of solvent fumes and prolonged exposure of skin to cleaning solvent. Wash exposed skin thoroughly. Dry cleaning solvent (P-D-680) used to clean parts is potentially dangerous to personnel and property. Do not smoke or use near open flame or excessive heat. Flash point of solvent is 100°F to 138°F (38°C to 59°C).

(1) Using P-D-680, or equivalent, clean area to be lubricated.

(2) Apply OE lubricating oil to personnel platform pivot points and to platform anchor quick-release pins.

Section V. PREVENTIVE MAINTENANCE CHECKS AND SERVICES**NOTE**

The PMCS chart in this section contains all necessary Unit preventive maintenance checks and services for this equipment.

4-10. General. The trailer assemblies and generator sets must be inspected and serviced systematically to insure that the power plant is ready for operation at all times. Inspection will allow defects to be discovered and corrected before they result in serious damage or failure. Table 4-1 contains a tabulated list of preventive maintenance checks and services to be performed by unit maintenance personnel. All of the unit PMCS on the trailers is scheduled to be performed Semiannually. Unit PMCS on the generator sets is scheduled weekly or on a per-hours-of-operation basis. The running time meters on the control panels are used to determine the operating time of the generator sets. Using the following as a guide, do the checks and services at the intervals shown. Observe all CAUTIONS and WARNINGS.

- a. For PMCS performed on an operating time basis, perform your hourly (H) PMCS as close as possible to the time intervals indicated.

NOTE

For units in continuous operation, perform PMCS before starting operation if continuous operation will extend service interval past that which is shown.

- b. Perform your weekly (W) PMCS every week or 40 hours of generator set operating time.
- c. Perform your monthly (M) PMCS every month or 100 hours of generator set operating time.
- d. Do your semiannual (S) PMCS once every six months.
- e. Do your annual (A) PMCS once every year.
- f. If you discover a problem with the equipment, refer to Section VI, Troubleshooting. If you cannot correct the problem, refer to paragraph 4-12, Reporting Deficiencies.

4-11. Explanation of Columns. The following is a list of the PMCS table column headings with a description of the information found in each column.

- a. *Item No.* This column shows the sequence in which checks and services are to be done, identify the equipment area on the Equipment Inspection and Maintenance Worksheet, DA Form 2404.

b. *Interval.* This column shows when each check is to be done.

c. *Item to be Inspected.* This column identifies the general area or specific part where the check or service is to be done.

d. *Procedures.* This column lists the checks or services you have to do and explains how to do them.

4-12. Reporting Deficiencies. If you discover any problem with the equipment during PMCS that you are unable to correct, it must be reported. Refer to DA Pam 738-750 and report the deficiency using the proper forms.

Table 4-1. Unit Preventive Maintenance Checks and Services (PMCS).

H - Hours of operation (As indicated) W - Weekly (40 hours) M - Monthly (100 hours) S - Semiannually (500 hours) A - Annually (1,000 hours)

Item No.	Interval					Item to be Inspected	Procedures
	H	W	M	S	A		
1		•				Hydraulic Sump	<p style="text-align: center;"><u>WARNING</u></p> <p>Before performing any maintenance that requires climbing on or under trailer, set trailer, handbrakes, chock wheels and lower rear leveling jacks. Injury to personnel could result from trailer suddenly rolling or tipping.</p> <p style="text-align: center;">NOTE</p> <p>This PMC table lists the checks and services as performed on a single power unit. These procedures must be duplicated on each of the two power units that make up the AN/MJQ-15.</p> <p>Check the fluid level. Add fluid as required.</p>
2				•		Generator Set Exterior	<p>Inspect generator set for fuel and oil leaks, loose or missing components and hardware, and unusual wear or deterioration. Clean generator set.</p> <p style="text-align: center;">NOTE</p> <p>Fuel system must be above freezing; temperature when draining water and sediment from strainer, filters and tank.</p>

Table 4-1. Unit Preventive Maintenance Checks and Services (PMCS).

H – Hours of operation
(As indicated)

W - Weekly
(40 hours)

M - Monthly
(100 hours)

S - Semiannually
(500 hours)

A - Annually
(1,000 hours)

Item No.	Interval					Item to be Inspected	Procedures
	H	W	M	S	A		
3			•			Fuel Strainer and Filters	Open drains on fuel strainer and primary and secondary fuel filters. Drain water and sediment. Allow to drain until fuel runs clean.
4			•			Fuel Tanks	Open drains on main fuel tank and day tank. Drain water and sediment. Allow to drain until fuel runs clean.
5				•		Fuel Pumps	Clean or replace, as necessary, fuel strainer in bottom of fuel pump.
6	100					Batteries	Perform a hydrometer test on batteries every 100 hours. Refer to TM 5-6115-464-12 for test procedures.
7	100					V-Belt	Inspect for worn, frayed, cracked or oil-soaked belt. Check adjustment. If necessary, adjust for a 1/2-inch deflection when belt is depressed at a point midway between alternator and water pump pulley.
8	100					Fuel Filters	Replace filter elements every 100 hours of operation.
9	300					Fuel Strainer	Clean fuel strainer every 300 hours of operation.
10	300					Lubricating Oil and Filters	Change lubricating oil and filters every 300 hours of operation or six months.
11	300					Breather and Breather Tube	Inspect for damage. Clean breather and tube at oil change interval.
12	500					Hydraulic Sump	Drain and refill (para 3-97, TM 5-6115-464-12)
13	500					Hydraulic Filter	Replace filter (para 3-97, TM 5-6115-464-12)
14	500					Hydraulic Actuator	Clean filter (para 3-98, TM 5-6115-464-12)

Table 4-1. Unit Preventive Maintenance Checks and Services (PMCS).

H - Hours of operation (As indicated) W - Weekly (40 hours) M - Monthly (100 hours) S - Semiannually (500 hours) A - Annually (1,000 hours)

Item No.	Interval					Item to be Inspected	Procedures
	H	W	M	S	A		
15	AR					Air Cleaner	Clean air cleaner element whenever necessary as indicated by air filter condition indicator light.
16				▶		Taillights	Replace any broken or cracked lenses or defective bulbs.
17				▶		Intervehicular Cable	Check for cuts, breaks, frayed wires and damaged plug.
18				▶		Lunette	Check security of mounting. Inspect for excessive wear.
19				▶		Safety Chains	Inspect for broken links or missing chain(s).
20				▶		Reflectors	Replace any cracked, broken or missing reflectors.
21				▶		Data Plates and Markings	Make sure data plates are legible and securely mounted. Replace illegible data plates.
22				▶		Landing Leg	Inspect landing leg and brace for bent or broken parts.
23				▶		Leveling Jacks	Inspect leveling jacks for bent or broken parts.
24				▶		Suspension Assemblies	a. Inspect shackles, bearings, pins, leaf springs and spring eyes for damage and broken parts. b. Inspect mounting brackets for cracks or loose or missing hardware.
25				●		Axle	a. Check for damaged axle tube. b. Check for loose or missing U-bolts or nuts.
26				●		Wheels and Tires	a. Check serviceability of tires as indicated in TM 9-2610-200-24. b. Tighten wheel stud nuts to 460 to 500 ft-lb (611 to 678 N-m).

Table 4-1. Unit Preventive Maintenance Checks and Services (PMCS).

H - Hours of operation (As indicated) W - Weekly (40 hours) M - Monthly (100 hours) S - Semiannually (500 hours) A - Annually (1,000 hours)

Item No.	Interval					Item to be Inspected	Procedures
	H.	W	M	S	A		
27				●		Brakes	a. Inspect brake linings for wear. Replace if brake shoe lining is less than 1/8-inch (3.2 mm) thick. b. Inspect brake adjusting screw, retaining pins, springs, and clips for corrosion and wear. c. Inspect hydraulic wheel cylinders for leaks. d. Adjust brakes.
28					●	Wheel Bearings	Clean and repack wheel bearings.
29				●		Hydraulic Brake Hoses and Fittings	Inspect for dents, cracks, loose connections and leaks.
30				●		Air Hoses and Fittings	Inspect for dents, cracks, loose connections and leaks.
31				●		Brake Master Cylinder	Check fluid level. Fill to 1/2 inch from top.
32				●		Trailer Road Test	Perform road test paying special attention to items that were repaired or adjusted, in accordance with TM 9-2330-205-14&P.

Section VI. TROUBLESHOOTING

4-13. General. Troubleshooting procedures for components unique to the power plant end item are given in paragraph 4-14. Troubleshooting information for the individual generator sets and trailers are contained in their respective manuals referenced below:

a. Generator Set Troubleshooting. Refer to TM 5-6115-464-12 for troubleshooting procedures applicable to the generator set.

b. Trailer Troubleshooting. Refer to TM 9-2330-205-14&P for troubleshooting procedures applicable to the trailers.

4-14. Power Plant Troubleshooting. Table 4-2 contains troubleshooting information for locating and correcting operating troubles which may develop in components unique to the power plant end item. Each malfunction is followed by a list of tests or inspections which will help determine probable cause and corrective actions to take. Perform the tests/inspections and corrective actions in the order listed. This manual cannot list all malfunctions that may occur, nor all tests or inspections and corrective actions. If a malfunction is not listed or cannot be corrected by listed corrective actions, notify your supervisor.

Table 4-2. Troubleshooting.

Malfunction	Test or inspection	Corrective action
1. POWER IS ABSENT AT SWITCH BOX LOAD TERMINAL(S) WHEN ONE PARTICULAR POWER UNIT IS SELECTED.		
	Step 1. Check if associated generator set circuit breaker is set to ON position.	If circuit breaker is in OFF position, reset to ON position.
	Step 2. Verify associated generator set output is as desired. Check generator output at load terminals.	If power is absent at generator set load terminals, troubleshoot generator set. (Refer to TM 5-6115-464-12.)
	Step 3. Perform continuity check on associated power unit power cable.	If cable is defective, notify higher level of maintenance.
	Step 4. Perform continuity check on associated switchbox connector.	If connector is defective, notify higher level of maintenance.
	Step 5. Perform continuity check on associated switch.	If switch is defective, notify higher level of maintenance.

Table 4-2. Troubleshooting – CONT.

Malfunction	Test or inspection	Corrective action
2. POWER IS ABSENT AT ONE OR MORE SWITCH BOX LOAD TERMINALS WHEN EITHER POWER UNIT IS SELECTED.	<p>Step 1. Check load terminal(s) for looseness or damage.</p> <p style="padding-left: 40px;">a. If terminal is loose, tighten.</p> <p style="padding-left: 40px;">b. If terminal is damaged, notify higher level of maintenance.</p> <p>Step 2. Inside switchbox, check wires associated with inoperative terminal(s) for looseness or broken wire terminals.</p>	<p style="padding-left: 40px;">Tighten loose connection, repair or replace broken wires.</p>
3. ONE OR MORE INDICATOR LAMPS DO NOT LIGHT WHEN POWER IS APPLIED BY POWER PLANT THROUGH SWITCH BOX.	<p>Step 1. Check bulb(s).</p> <p style="padding-left: 40px;">Replace bulb(s) if defective.</p> <p>Step 2. Inspect wires associated with inoperative indicator. Check wire terminals for looseness.</p> <p style="padding-left: 40px;">Tighten loose connections. Replace broken wires.</p> <p>Step 3. Perform continuity check on indicator housing.</p> <p style="padding-left: 40px;">If indicator housing is defective, replace.</p>	

Section VII. RADIO INTERFERENCE SUPPRESSION

4-15. General Methods Used to Attain Proper Suppression. Essentially, suppression is attained by providing a low resistance path to ground for stray currents. The methods used include shielding ignition and high-frequency wires, grounding the frame with bonding straps, and using filtering systems.

4-16. Radio Interference Suppression Components. All component parts on the power plant end item, whose primary or secondary function is radio interference suppression, are on the generator sets. Refer to TM 5-6115-464-12 for location of radio interference suppression components.

Section VIII. MAINTENANCE OF POWER PLANT TRAILERS

4-17. General. This section of the manual contains unit level maintenance procedures for components of the M200A1 trailer added when the trailer is used as part of the AN/MJQ-15 power plant. These components are not covered in the overall trailer maintenance manual. For all other unit maintenance procedures on the trailer, refer to TM 9-2330-205-14&P.

WARNING

Before performing any maintenance that requires climbing on or under trailer, set trailer handbrakes, chock both wheels, and lower rear leveling jacks. Injury to personnel could result from trailer suddenly rolling or tipping.

4-18. Fuel Can Bracket Replacement. (See figure 4-5.) There are four fuel can brackets supplied with the AN/MJQ-15. Two brackets are mounted on top of the curbside front steps on each power unit. Replacement procedures described below are typical for all.

a. Removal.

- (1) Remove four screws (1, figure 4-5), four nuts (2) and four flat washers (3) securing bracket (4) to step (5).
- (2) Remove bracket (4) from step (5).

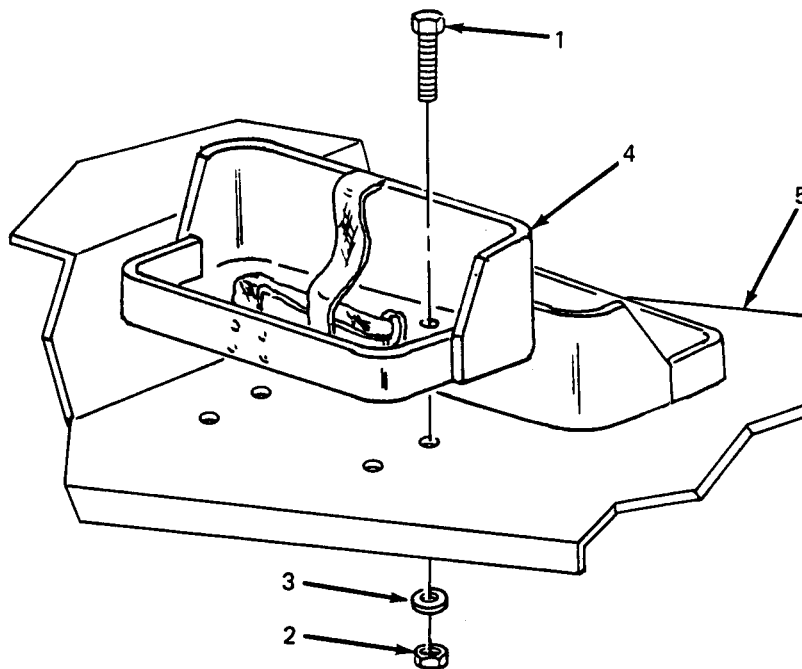

Figure 4-5. Fuel Can Bracket Replacement.

b. Installation.

- (1) Position fuel can bracket (4) on step (5).
- (2) Insert four screws (1) down through bracket (4) and through step (5).
- (3) Install one washer (3) and one nut (2) on each screw (1). Tighten hardware to secure bracket (4).

4-19. Accessory Box Replacement. (See figure 4-6.) The accessory boxes are mounted to the trailer frames at the curbside front steps. Replacement procedures are typical.

a. Removal.

- (1) Remove three screws (1, figure 4-6), three flat washers (2), and three nuts (3) securing accessory box (4) to trailer frame (5).
- (2) Slide accessory box (4) forward and off of front step (6).

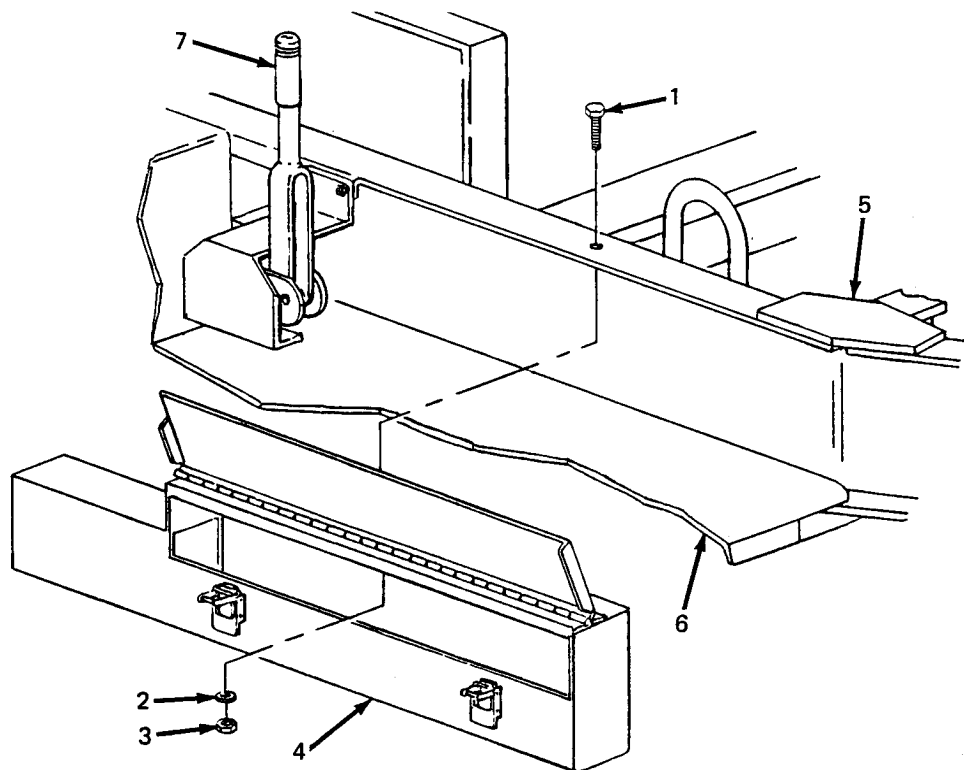

Figure 4-6. Accessory Box Replacement.

b. Installation.

- (1) Position accessory box (4) on front trailer step (6) with narrow end between handbrake lever (7) and trailer frame (5).
- (2) Lift accessory box (4) so that top of box contacts lip of trailer frame (5).

(3) Insert three screws (1) down through trailer frame (5) into accessory box (4).

(4) Install one nut (3) and one washer (2) on each screw (1) and tighten.

4-20. Fire Extinguisher Bracket Replacement. (See figure 4-7.) The fire extinguishers supplied with the power plant are carried in brackets mounted on the front roadside steps of the trailers.

a. Removal.

(1) Remove four screws (1, figure 4-7), four flat washers (2), and four nuts (3) securing bracket (4) to step (5).

(2) Remove bracket (4) from step (5).

b. Installation.

(1) Position fire extinguisher bracket (4) on step (5).

(2) Insert four screws (1) down through bracket (4) and through step (5).

(3) Install one washer (2) and one nut (3) on each screw (1). Tighten hardware to secure bracket (4).

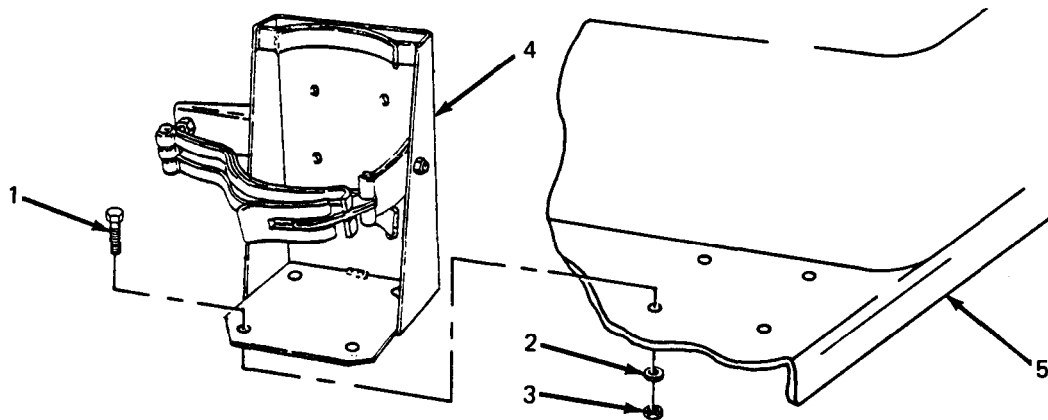

Figure 4-7. Fire Extinguisher Bracket Replacement.

4-21. Front Steps Replacement. (See figure 4-8.) The roadside and curbside front steps on both trailers are symmetrical, and replacement procedures are the same except where noted in the steps below.

a. Removal.

NOTE

When removing roadside front step, omit steps (1) and (2).

(1) Remove fuel can brackets (paragraph 4-18, a).

(2) Remove accessory box (paragraph 4-19, a).

- (3) Remove cotter pin (1, figure 4-8) and clevis pin (2) securing handbrake cable (3) to handbrake lever mechanism (4).
- (4) Remove two screws (5), two flat washers (6) and two nuts (7) securing handbrake bracket (8) to trailer frame (9).
- (5) Remove two screws (10), two flat washers (11) and two nuts (12) securing handbrake cable (13) to front step (14).

NOTE

There are two screws, flat washers, and nuts securing handbrake bracket to front step. It is only necessary to remove one set of attaching hardware to remove front step from trailer frame.

- (6) Remove screw (15), flat washer (16), lockwasher (17) and nut (18) directly beneath pivot point of handbrake lever (4).
- (7) Remove seven screws (19), 14 flat washers (20) and seven nuts (21) securing front step (14) to front edge of fender (22).
- (8) Remove four screws (23, 24 and 25), eight flat washers (26) and four nuts (27) securing front step (14) to edge of trailer frame (9).
- (9) Remove three screws (28), three flat washers (29) and three nuts (30) securing front step (14) to trailer cross braces (31) and remove front step.

b. Installation.

NOTE

Three different length screws are used to mount the front step. Screws with index numbers (5), (10), (18) and (23) in Figure 4-8 are one inch long. Screw with index number (24) is 1-1/4 inch long. Screws with index numbers (15), (22) and (27) are 1-3/4 inch long. Observe lengths and locations when installing hardware.

- (1) Position front step (14) on cross braces (31) and trailer frame (9). Insert clevis on handbrake cable (3) through hole in front step (14).
- (2) Insert four screws (23, 24 and 25) with flat washers (26) through front step (14) and trailer frame (9).
- (3) Insert three screws (28) with flat washers (29) through front step (14) and trailer cross braces (31).
- (4) Working under step, install one nut (30) on each screw (28) securing front step (14) to cross braces (31), and install one flat washer (26) and one nut (27) on each screw (23, 24 and 25) securing step to trailer frame (9). Tighten seven sets of hardware.

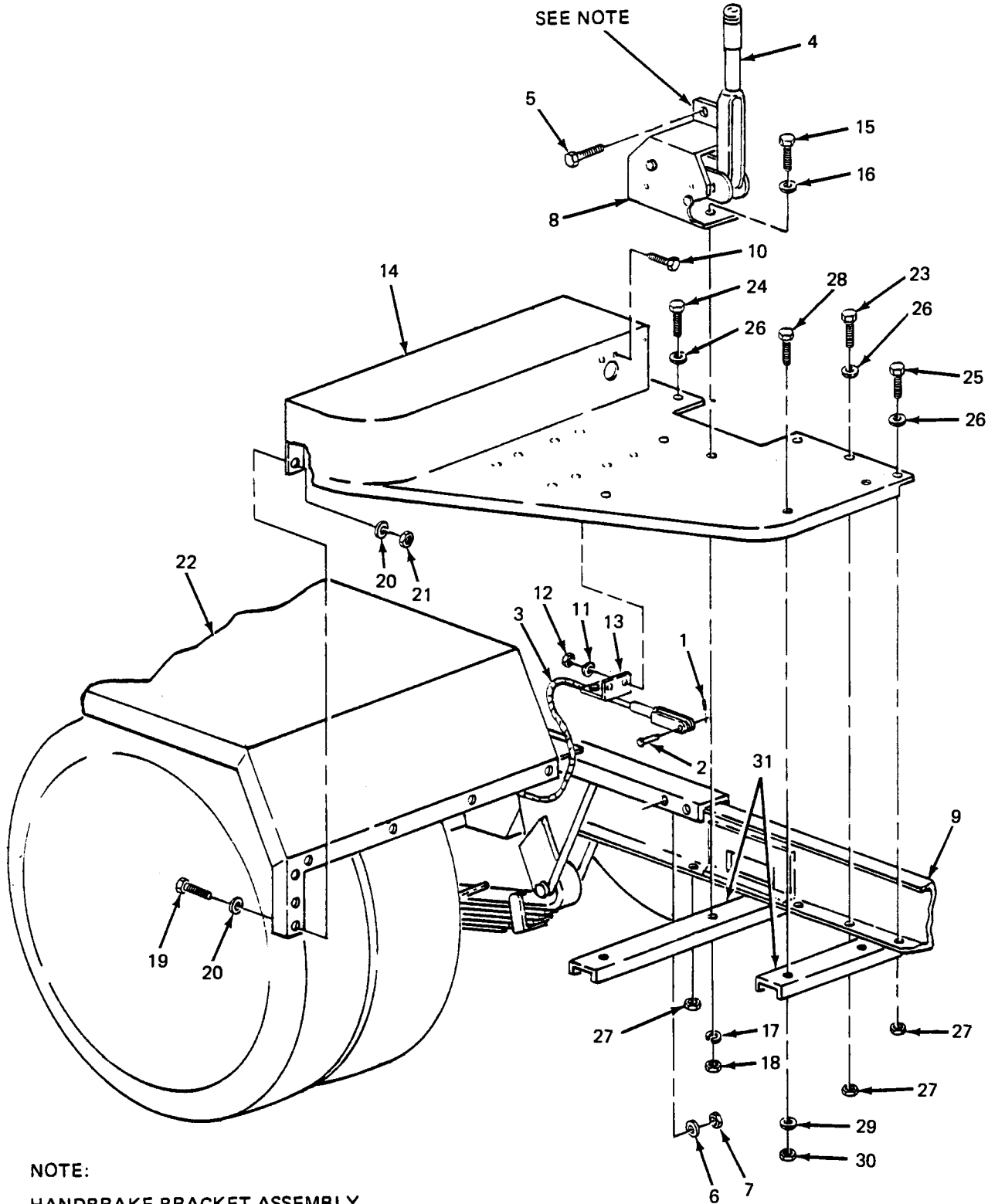

NOTE:
HANDBRAKE BRACKET ASSEMBLY
EXPLODED FOR CLARITY

Figure 4-8. Front Steps Replacement.

- (5) Secure front step (14) to fender (22) with seven screws (19), 14 flat washers (20) and seven nuts (21).
- (6) Insert screw (15) with flat washer (16) through handbrake bracket (8), front step (14) and cross brace (31). Install lockwasher (17) and nut (18) on screw from underneath and tighten.
- (7) Insert two screws (5) with flat washers (6) through handbrake bracket (8) and trailer frame (9). Install one nut (7) on each screw and tighten.
- (8) Insert two screws (10) through front step (14) and handbrake cable bracket (13). Install one flat washer (11) and one nut (12) on each screw and tighten.
- (9) Position handbrake cable clevis (31) on handbrake lever mechanism (4). Insert clevis pin (2) and secure with cotter pin (1).

NOTE

When installing roadside front step, omit steps (10) and (11).

- (10) Install accessory box (paragraph 4-19, b).
- (11) Install fuel can brackets (paragraph 4-18, b).

4-22. Rear Steps Replacement. (See figure 4-9.) The roadside and curbside rear steps on both trailers are symmetrical, and replacement procedures are the same for all.

a. Removal.

- (1) Remove two screws (1, figure 4-9), two flat washers (2) and two nuts (3) securing rear step bracket (4) and platform anchor (5) to trailer frame (6) under taillight (7).
- (2) Remove two screws (8), four flat washers (9) and two nuts (10) securing rear step (11) to trailer frame (6).
- (3) Remove five screws (12), ten flat washers (13) and five nuts (14) securing rear step (11) to fender (15). Remove rear step from trailer.

b. Installation.

- (1) Position rear step (11) on trailer frame (6).
- (2) Secure rear step (11) to trailer frame (6) with two screws (8), four flat washers (9) and two nuts (10).
- (3) Secure rear step (11) to fender (15) with five screws (12), ten flat washers (13) and five nuts (14).
- (4) Aline two mounting holes in rear step bracket (4) with holes in trailer frame (6) under taillight (7) and insert two screws (1),
- (5) Slide S-hook at chain end of platform anchor (5) onto threaded end of lower screw (1) inside trailer frame (6).

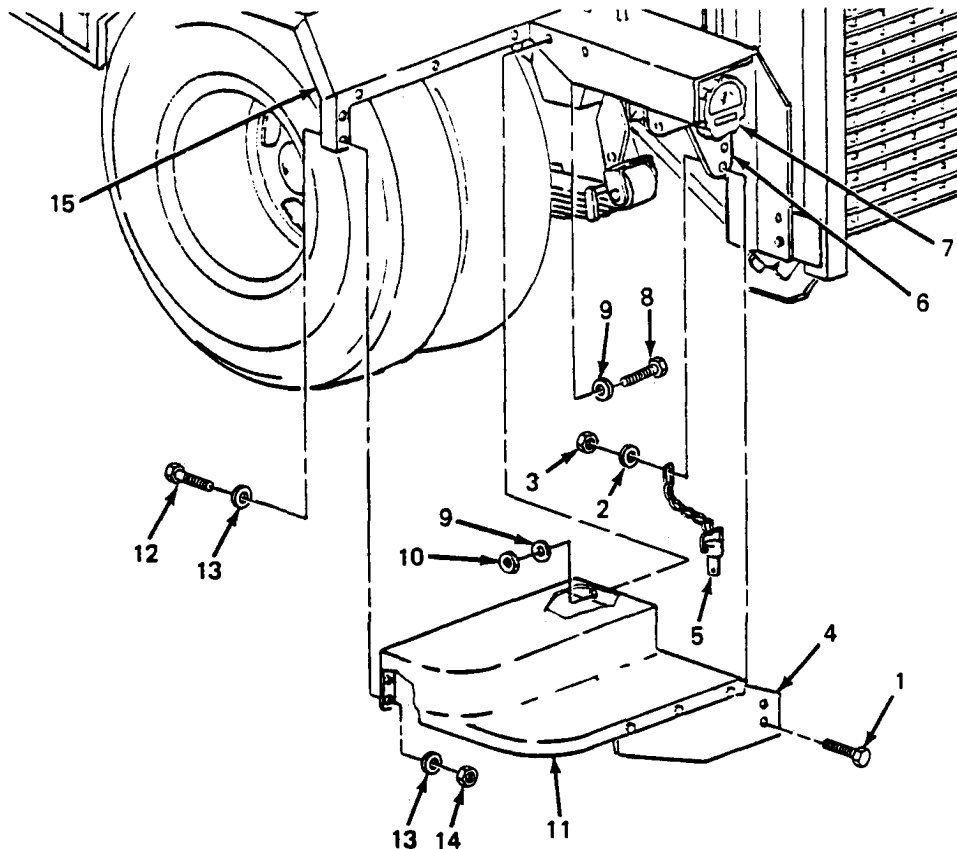

Figure 4-9. Rear Steps Replacement.

(6) Install one flat washer (2) and one nut (3) on each screw (1) and tighten.

4-23. Fender Replacement. (See figure 4-10.) The fenders on the trailer assemblies are symmetrical, and replacement procedures are the same for all.

a. Removal.

(1) Remove five screws (1, figure 4-10), ten flat washers (2) and five nuts (3) securing fender (4) to trailer frame (5).

WARNING

There are five sets of hardware securing fender to rear step and seven sets of hardware securing fender to front step. This hardware should be removed in sequence from trailer frame outward. In this way, last two screws on front and rear lower fender edge will support fender until you are out from underneath.

(2) Remove six screws (6), 12 flat washers (7) and six nuts (8) securing fender (4) to front step (9).

(3) Remove four screws (10), eight flat washers (11) and four nuts (12) securing fender (4) to rear step (13).

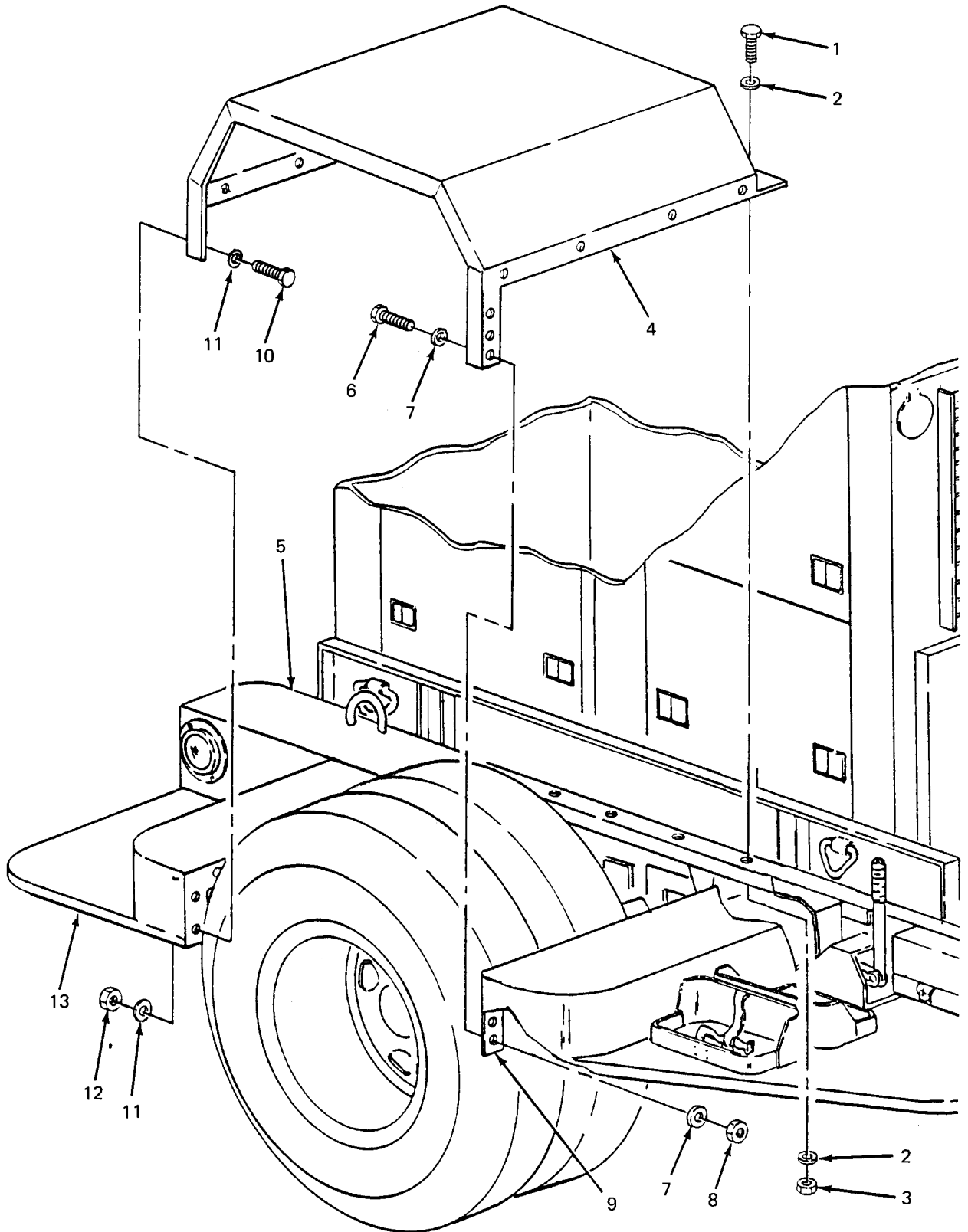

Figure 4-10. Fender Replacement.

WARNING

Support fender while removing remaining two screws. When screws are removed, fender will drop.

- (4) Remove one screw (6), two flat washers (7) and one nut (8) securing fender (4) to front step (9).
- (5) Remove one screw (10), two flat washers (11) and one nut (12) securing fender (4) to rear step (13).
- (6) Remove fender (4).

b. Installation.

- (1) Position fender (4) on trailer.
- (2) Insert one screw (10) with flat washer (11) through lower outside edge of fender (4) into rear step (13), and insert one screw (6) with flat washer (7) through lower outside edge of fender (4) into front step (9).
- (3) Install one washer (11) and one nut (12) on screw (10), and one washer (7) and one nut (8) on screw (6). Tighten hardware.
- (4) Insert five screws (1) with flat washers (2) down through fender (4) into trailer frame (5).
- (5) Working under fender, install one flat washer (2) and one nut (3) on each screw (1) and tighten.
- (6) Insert six screws (6) with flat washers (7) through fender (4) into front step (9). Install one washer (7) and one nut (8) on each screw (6) and tighten.
- (7) Insert four screws (10) with flat washers (11) through fender (4) into rear step (13). Install one washer (11) and one nut (12) on each screw (10) and tighten.

4-24. Personnel Platform Replacement. (See figure 4-11). This platform is mounted on the rear of each trailer to facilitate access to generator set controls and indicators.

a. Removal.

- (1) Remove two screws (1, figure 4-11), four flat washers (2) and two nuts (3) securing platform (4) to mounting brackets (5).

WARNING

Support platform while removing anchors. When anchors are removed, platform will drop.

- (2) Remove two platform anchors (6) by pushing in on button on head of pin while pulling pin out of mounting hole.

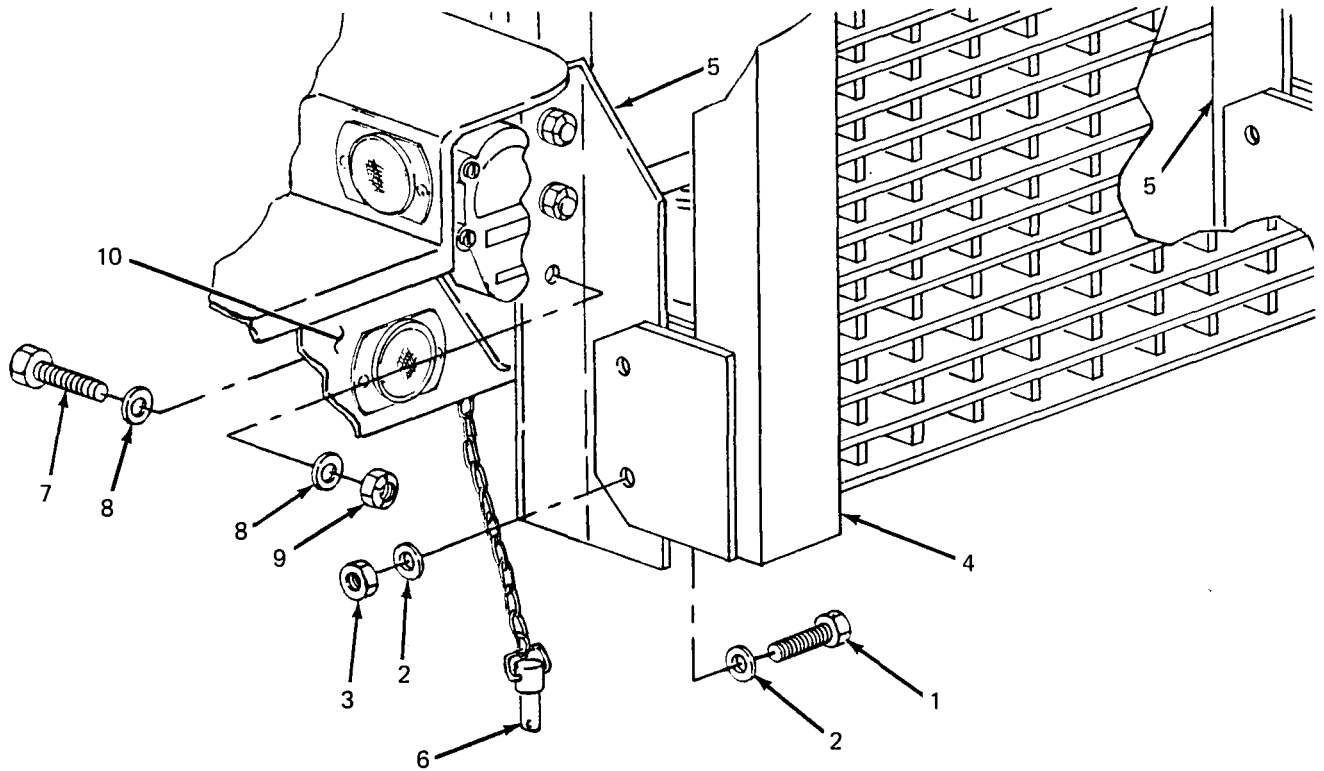

Figure 4-11. Personnel Platform Replacement.

NOTE

Mounting brackets are fastened with lock nuts. Removal may inhibit locking capability when reinstalled. Do not remove mounting brackets unless they are damaged.

- (3) Remove three screws (7), six flat washers (8) and three nuts (9) from each mounting bracket (5) and take mounting brackets off of trailer frame (10).

b. Installation.

NOTE

If mounting brackets have not been removed, omit step (1),

- (1) Position each mounting bracket (5) on trailer frame (10). Insert three screws (7) with flat washers (8) through frame into each bracket. Install one washer (8) and one nut (9) on each screw and tighten.

- (2) Holding platform (4) in vertical position, position platform on mounting brackets (5) so holes in platform line up with holes in brackets and install platform anchors (6) in upper mounting hole on each side of platform.
- (3) Secure platform (4) to brackets (5) with two screws (1), four flat washers (2) and two nuts (3).

4-25. Holddown Strap Replacement. (See figure 4-12). Three holddown straps are provided on the roadside fender of each power unit. These straps are used to secure the power cables when the power plant is in transit. Replacement procedure is typical.

a. Removal.

- (1) Remove two screws (1, figure 4-12), two washers (2), and two nuts (3) securing footmans loop (4) to trailer (5).
- (2) Slide holddown strap (6) off footmans loop (4).

b. Installation.

- (1) Slide holddown strap (6) onto footmans loop (4).
- (2) Position footmans loop (4) on trailer body (5) and secure with two screws (1), two washers (2), and two nuts (3).

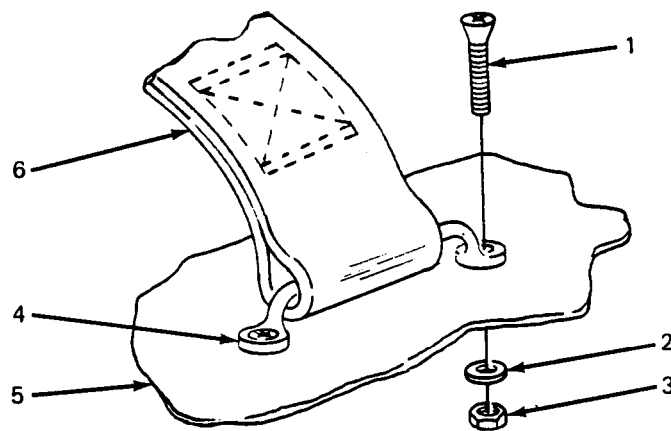

Figure 4-12. Holddown Strap Replacement.

SECTION IX. MAINTENANCE OF ELECTRICAL SYSTEM

4-26. General. This section of the manual contains unit level maintenance procedures for electrical components that are unique to the AN/MJQ-15 power plant. Specifically, this includes the switch box and the power cables.

4-27. Cable Testing. A continuity test is used to detect opens or shorts in the power plant power cables. The following test procedure is typical for both.

- a. Set multimeter controls to prepare unit for continuity testing.

NOTE

The contacts in the connector end of cable are labeled A, B, C, N, and G.
The individual colored wires at the other end of cable are labeled L0, L1, L2, L3, and GEN GND.

- b. Touch one probe to contact A in connector and touch remaining probe to black wire labeled L1. Multimeter must indicate continuity. If it does not, cable is open.
- c. With first probe still in contact A, touch remaining probe to wires labeled L2, L3, L0, and GEN GND. Multimeter must not indicate continuity. If it does, cable is shorted.
- d. Refer to figure 4-13, and repeat steps b. and c. at connector contacts B, C, and N. In each case, continuity must exist between corresponding points and only between corresponding points.

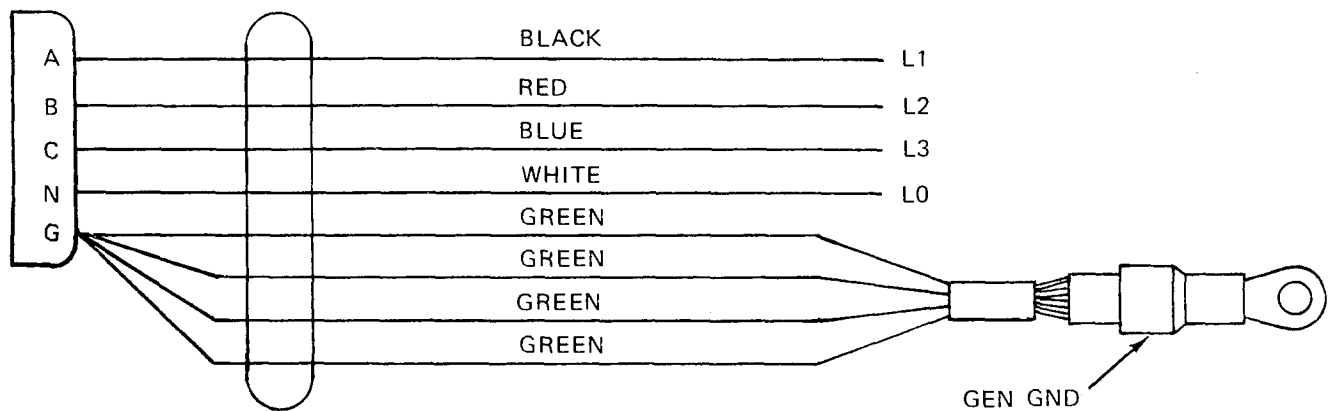

Figure 4-13. Power Cable Wiring Diagram.

- e. Connect one multimeter probe to GEN GND lug on cable and touch remaining probe to contact G in connector. Multimeter must indicate continuity.
- f. If continuity test detects any opens or shorts in cable, refer cable to higher level of maintenance.

4-28. Switch Box Testing. The power plant switch box assembly is tested by performing a series of continuity checks on the component parts and internal wiring.

NOTE

All internal switch box wiring is labeled for identification with reference designations of its points of connection. If labeling has been removed, or is illegible, tag wires for identification before removing them.

- a. Switch Testing. The switch box contains two three-pole, single-throw switches. Testing procedures are typical for both.

WARNING

To avoid risk of injury or death by electrocution, do not remove switch box rear cover while either power unit is still connected to switch box.

- (1) Remove 18 screws, 18 lockwashers, and 18 flat washers securing rear cover to switch box and remove cover.
- (2) Set multimeter controls to prepare unit for continuity testing.
- (3) Set switch being tested to ON position.

NOTE

Observe that the switch terminals are arranged in two rows of three terminals each. Each terminal is paired with the one directly above or below it. There is one pair of terminals for each pole of the switch.

- (4) Select any pair of terminals associated with same pole of switch. Touch one multimeter test probe to each terminal. Multimeter must indicate continuity.
- (5) Repeat step (4) on both remaining poles of switch.
- (6) If multimeter does not indicate continuity across all three poles of switch, switch is defective. Refer switch to higher level of maintenance.

b. Connector Testing. The switch box has four male cable connectors. The larger connectors, J1 and J2, are the power input connectors. Together with their associated wiring, they comprise the switch box cable assemblies. This procedure tests the entire cable assembly. The procedure is as follows:

WARNING

To avoid risk of injury or death by electrocution, do not remove switch box rear cover while either power unit is still connected to switch box.

NOTE

Observe that pins on power input connectors are labeled A, B, C, N, and G.

- (1) Remove 18 screws, 18 lockwashers, and 18 flat washers securing rear cover to switch box and remove cover.
- (2) Set multimeter controls to prepare unit for continuity testing.
- (3) Touch one multimeter test probe to pin A in connector being tested and touch remaining probe to terminal C on associated switch. Multimeter must indicate continuity. If it does not, there is an open in connector or associated wire.
- (4) With first probe still in contact with pin A, touch remaining probe to all other pins in connector. Multimeter must not indicate continuity. If it does, connector is shorted.
- (5) Repeat steps (3) and (4) for pins B and C. Multimeter must indicate continuity only between these pins and switch terminals B and A, respectively.

- (6) Touch one multimeter test probe to connector pin N. Touch remaining probe to switch box load terminal L0. Multimeter must indicate continuity.
- (7) Touch one multimeter test probe to connector pin G. Touch remaining probe to GROUND TERMINAL stud on switch box. Multimeter must indicate continuity.
- (8) If continuity test detects any opens or shorts, connector cable assembly is defective:

c. Wiring Test. (Refer to wiring diagrams, Figure 4-14.) The internal switch box wiring is tested by performing a continuity check(s) on suspect wires or connections.

WARNING

To avoid risk of injury or death by electrocution, do not remove switch box rear cover while either power unit is still connected to switch box.

NOTE

All internal switch box wiring is labeled for identification with reference designations of its points of connection. If labeling has been removed, or is illegible, tag wires for identification before removing them.

- (1) Remove 18 screws, 18 lockwashers, and 18 flat washers securing rear cover to switch box and remove cover.
- (2) Before testing wires, make sure there are no loose connections or broken terminals. Tighten any loose connections and refer broken terminals to higher level of maintenance.
- (3) Set multimeter controls to prepare unit for continuity testing.
- (4) Refer to applicable wiring diagram in Figure 4-14, and test continuity of suspect wires between origin and destination specified in diagram.

4-29. Switch Box Repair. The power plant switch box assembly is repaired by replacing defective components. Components authorized for replacement at unit level of maintenance include connector cable assemblies, load terminals, and individual wires.

NOTE

All internal switch box wiring is labeled for identification with reference designations of its points of connection. If labeling has been removed, or is illegible, tag wires for identification before removing them.

a. Connector Replacement. (See figure 4-15.) A damaged or defective connector is replaced by replacing the entire connector cable assembly.

WARNING

To avoid risk of injury or death by electrocution, do not remove switch box rear cover while either power unit is still connected to switch box.

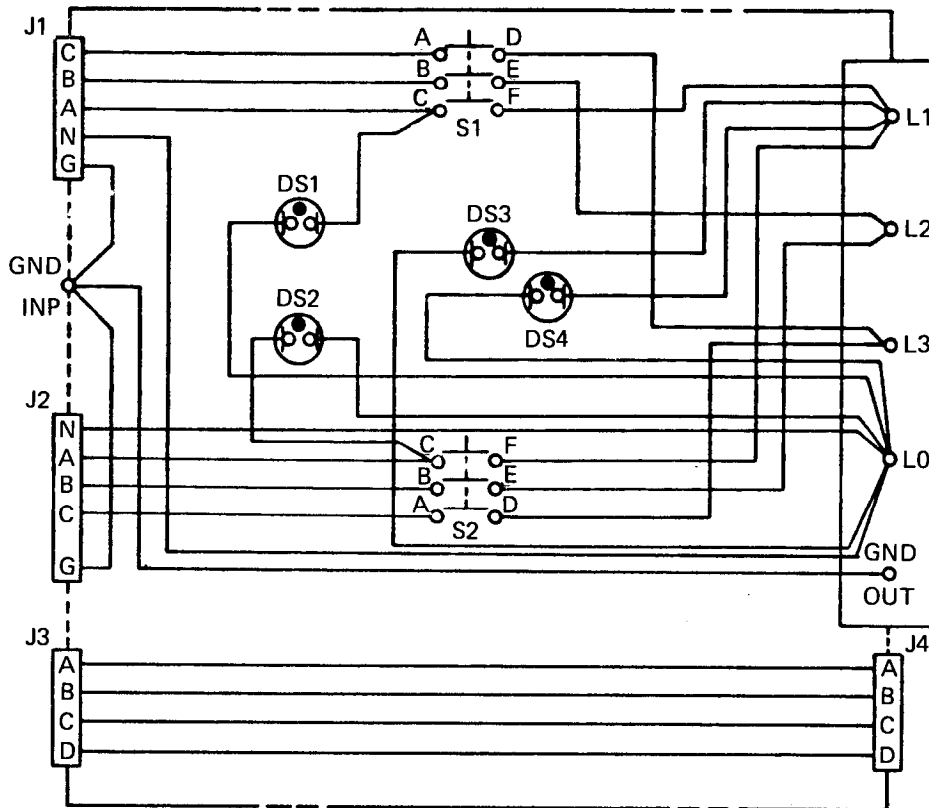

COMPONENT REFERENCE LIST					
REF DES	PART NO.	NOMENCLATURE	REF DES	PART NO.	NOMENCLATURE
S1	13220E6428	SWITCH	J3	MS3102R18-4P	CONNECTOR, RCPT
S2	13220E6428	SWITCH	J4	MS3102R18-4P	CONNECTOR, RCPT
DS1	13214E1391	LIGHT, INDICATOR	L0	13218E5066-2	TERMINAL LOAD
DS2	13214E1391	LIGHT, INDICATOR	L1	13218E5066-2	TERMINAL LOAD
DS3	13214E1391	LIGHT, INDICATOR	L2	13218E5066-2	TERMINAL LOAD
DS4	13214E1391	LIGHT, INDICATOR	L3	13218E5066-2	TERMINAL LOAD
J1	MS90558C32413P(Y)	CONNECTOR, RCPT	GND OUT	13218E5066-2	TERMINAL LOAD
J2	MS90558C324L3P(Y)	CONNECTOR, RCPT	GND INP	1321E1223	STUD

Figure 4-14. Switch Box Wiring Diagram.

(1) *Removal.*

- (a) Remove 18 screws (1), 18 lockwashers (2), and 18 flat washers (3) securing rear cover (4) to switch box (5) and remove cover.
- (b) Disconnect connector cable assembly wires (6) from load terminal L0, GROUND TERMINAL stud, and associated switch.
- (c) Remove four screws (7) and four nuts (8) securing connector flange (9) to switch box (10).
- (d) Carefully remove connector and associated wiring from switch box.

(2) *Installation.*

- (a) Feed connector cable assembly wires (6) through mounting hole in switch box (10).
- (b) Position connector body in mounting hole and secure with four screws (7) and four nuts (8). Use screw in lower right-hand corner of flange to secure connector cap retaining chain (11).
- (c) Install connector cable assembly wires (6) on load terminal L0, GROUND TERMINAL stud, and associated switch (figure 4-14).
- (d) Position rear cover (4) on switch box (5) and secure with 18 screws (1), 18 lockwashers (2), and 18 flat washers (3).

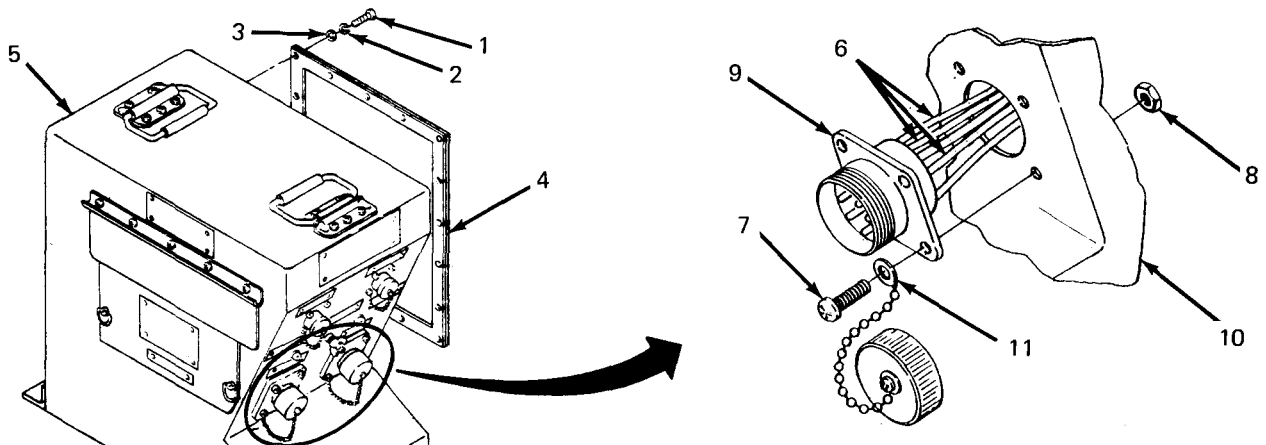

Figure 4-15. Connector Replacement.

b. Load Terminal Replacement. (See figure 4-16.) The switch box load terminals provide electromechanical connection points between the system or equipment being powered and the power plant. In addition to the four output terminals, the switch box utilizes a fifth load terminal as a ground connection for the system or equipment being powered.

WARNING

To avoid risk of injury or death by electrocution, do not remove switch box rear cover while either power unit is still connected to switch box.

(1) *Removal.*

- (a) Remove 18 screws (1), 18 lockwashers (2), and 18 flat washers (3) securing rear cover (4) to switch box (5) and remove cover.
- (b) Remove one nut (6), one lockwasher (7), one flat washer (8), and remove associated wires (9) from load terminal (10).
- (c) Open power output cover and remove six nuts (11) and six lockwashers (12) and remove load terminal protective cover (13).
- (d) Remove one nut (14), one lockwasher (15), and one flat washer (16) and remove load terminal (10) from terminal board (17).

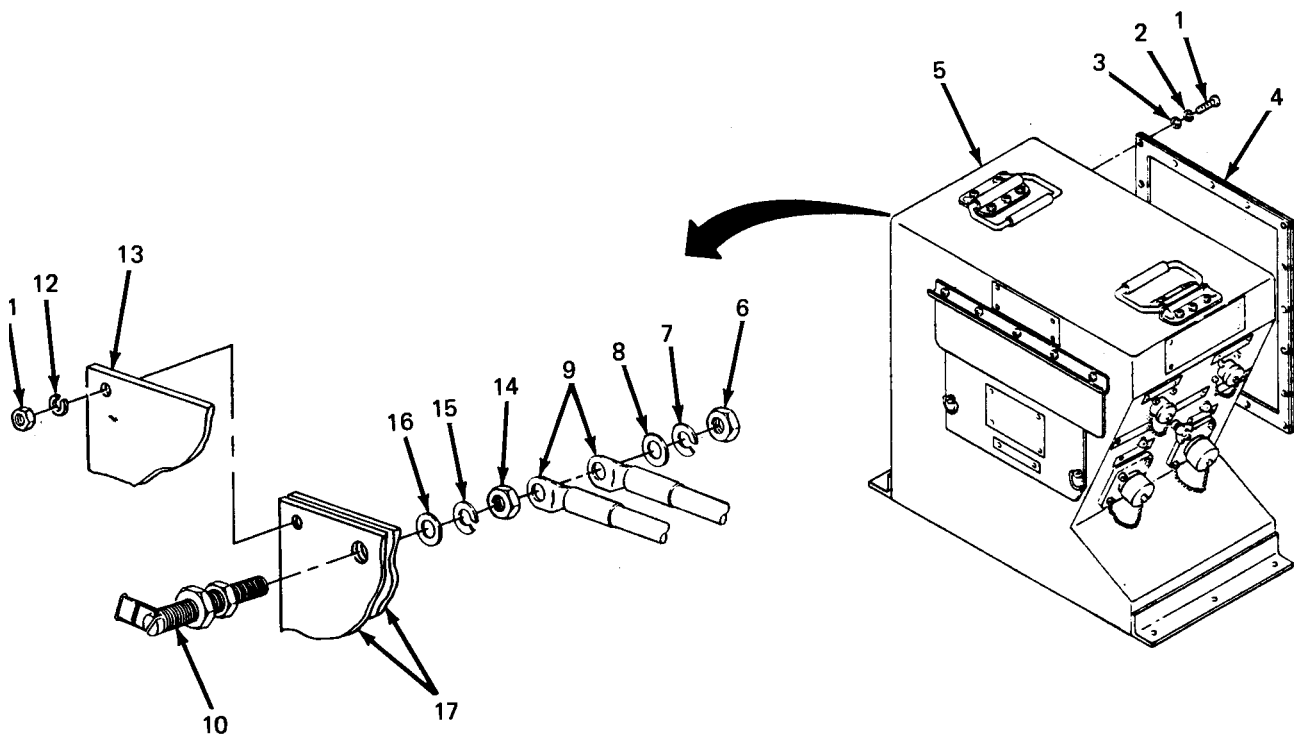

Figure 4-16. Load Terminal Replacement.

(2) *Installation.*

- (a) Install load terminal (10) in terminal board (17) and secure with flat washer (16), lockwasher (15) and nut (14).
- (b) Install associated wires (9) on load terminal (10) and secure with flat washer (8), lockwasher (7), and nut (6).
- (c) Position load terminal protective cover (13) over terminals and secure with six nuts (11) and six lockwashers (12).
- (d) Position rear cover (4) on switch box (5) and secure with 18 screws (1), 18 lockwashers (2), and 18 flat washers (3).

CHAPTER 5

INTERMEDIATE (FIELD) (DIRECT SUPPORT AND GENERAL SUPPORT) MAINTENANCE INSTRUCTIONS

Section I. INTRODUCTION

5-1. General. This chapter contains Intermediate Direct Support and General Support level maintenance procedures for components of the M200A1 trailer added when the trailer is used as part of the AN/MJQ-15 power plant. These components are not covered in the overall trailer maintenance manual. For all other intermediate direct and general support maintenance procedures on the trailer, refer to TM 9-2330-205-14&P. For intermediate direct and general support maintenance procedures on the generator sets, refer to TM 5-6115-464-34.

WARNING

Before performing any maintenance that requires climbing on or under trailer, set trailer handbrakes, chock wheels, and lower rear leveling jacks. Injury to personnel could result from trailer suddenly rolling or tipping.

Section II. MAINTENANCE OF POWER PLANT TRAILERS.

5-2. Step and Fender Repair. Repair of the front and rear steps and the fenders is limited to straightening, welding and repainting. If required, repaint in accordance with MIL-T-704, Type F, Color Green, No. 383 of MIL-C-46168.

5-3. Accessory Box Repair. (See figure 5-1.) The accessory boxes are repaired by replacing the latch and strike assemblies. The boxes themselves may be straightened, welded and repainted. If required, repaint in accordance with MIL-T-704, Type F, Color Green, No. 383 of MIL-C-46168. Replace latch and strike assemblies as follows:

- a. Grind off or drill out solid rivets (1, figure 5-1) securing latch and strike assembly (2) to accessory box (3).
- b. Position new latch and strike assembly (2) on accessory box (3) and secure with solid rivets (1).
- c. Touch up with paint as required.

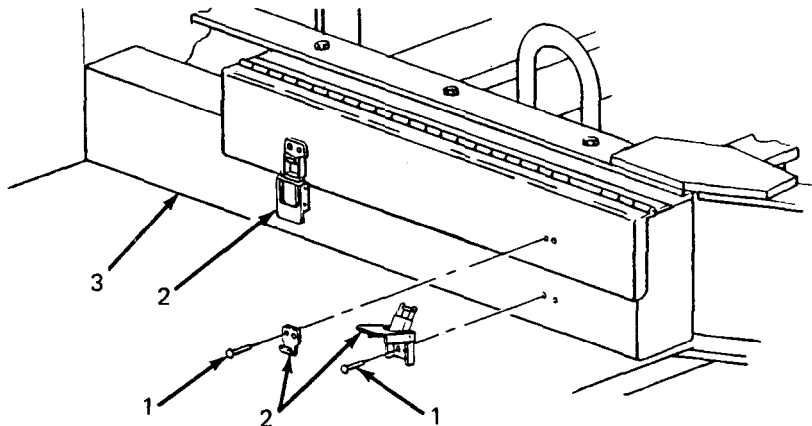

Figure 5-1. Accessory Box Repair.

5-4. Marking. (See figure 5-2.) The power plant four-digit registration number, preceded by the prefix "VB" and the words "U.S. ARMY", is marked in three places on each power unit trailer. Marking is done in accordance with MIL-STD-642. On the fender, over each wheel, "T.P. 35 PSI" is marked in $1.00 \pm .12$ inch high characters in accordance with MIL-STD-130. Figure 5-2 shows the approximate location of markings on one power unit of the power plant. Markings are typical of both power units. If required, touch-up painting of the base color shall be done in accordance with MIL-T-704, Type F, Color Green, No. 383 of MIL-C-46168.

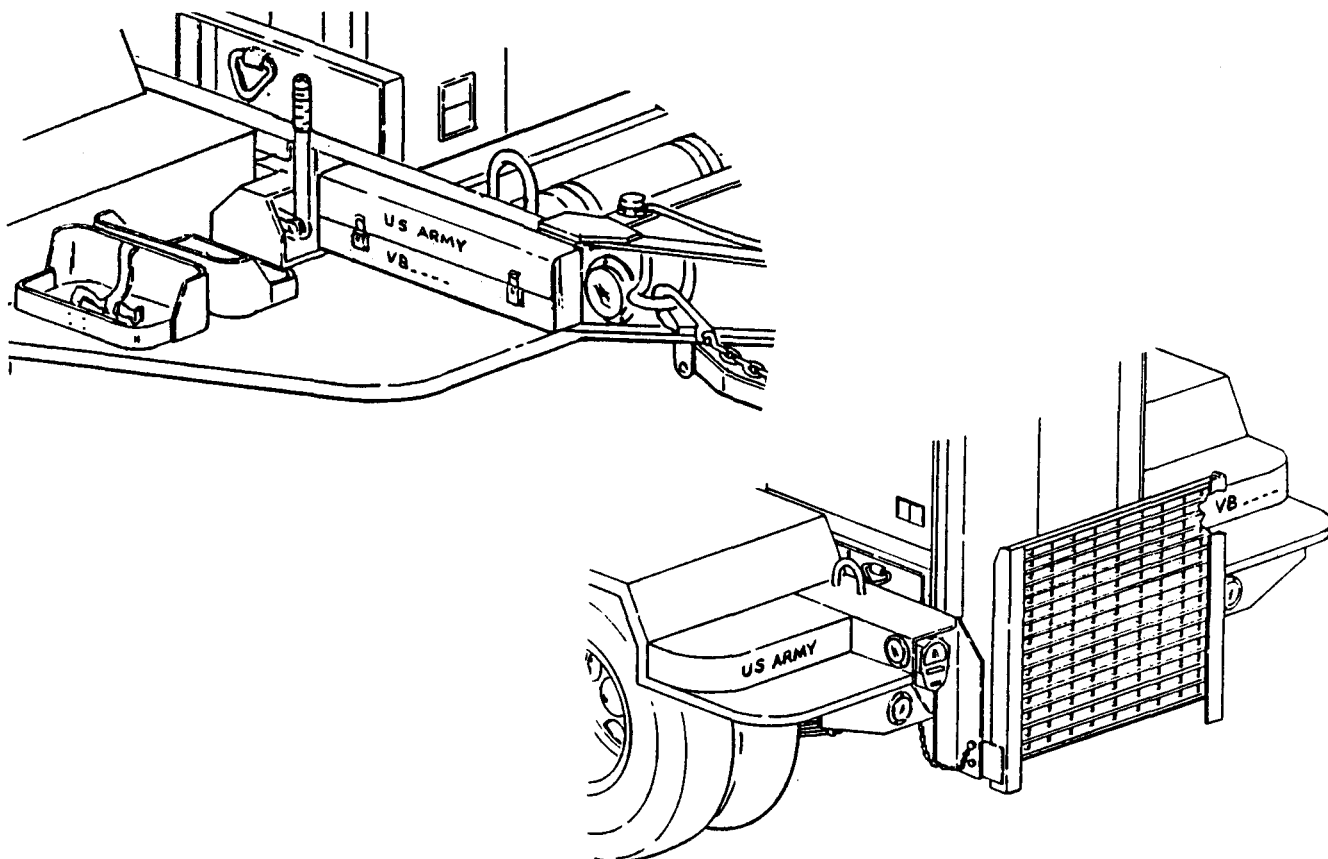

Figure 5-2. Power Plant Markings.

Section III. GENERATOR SET

5-5. Generator Set Replacement. (See figures 5-3 and 5-4.)

a. Removal.

- (1) Disconnect ground wire (1, figure 5-3) from generator set (2) to GROUND TERMINAL stud (3) on trailer.

NOTE

Beveled washers (5) may have been welded in place.

- (2) Remove four screws (4), four beveled washers (5), four lockwashers (6) and four nuts (7) securing generator set (2) to trailer.

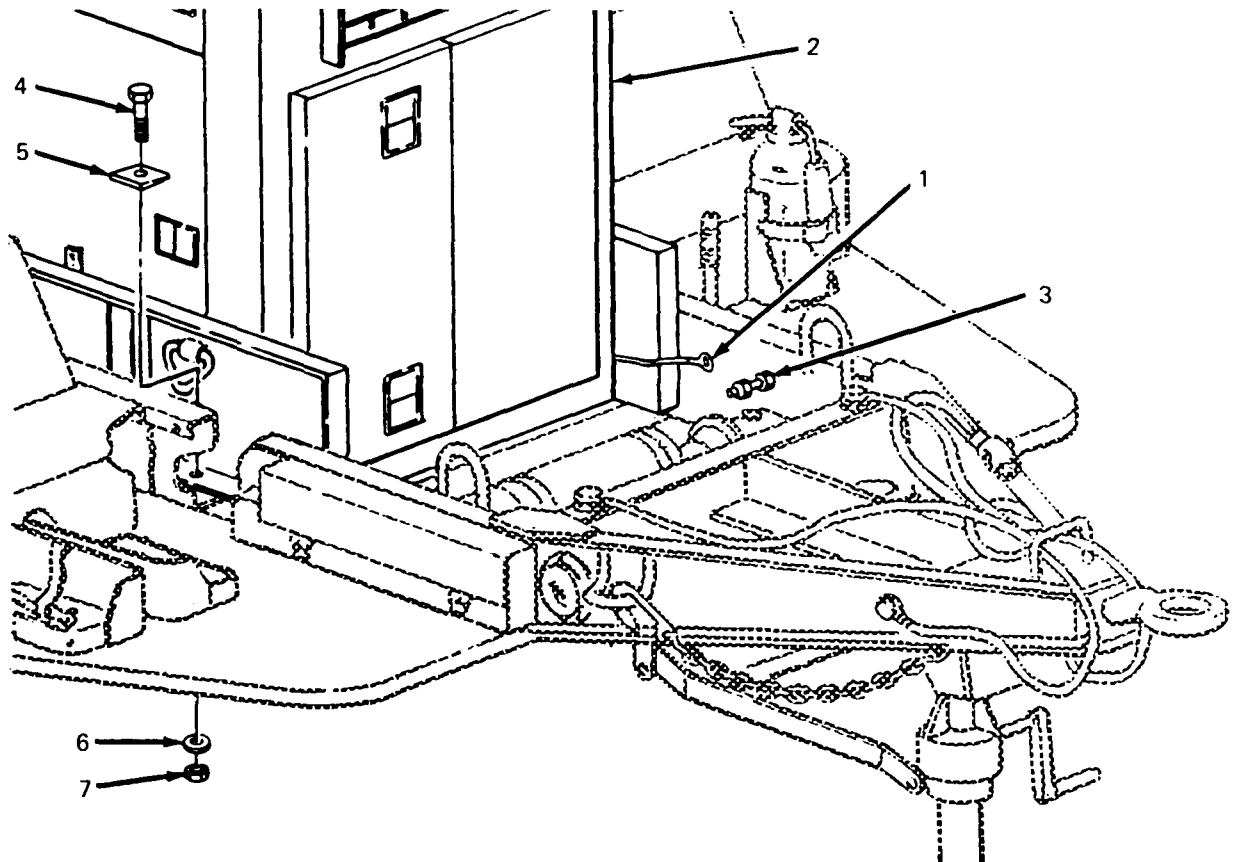

Figure 5-3. Detaching Generator Set from Trailer.

WARNING

When lifting generator set, use lifting equipment with a minimum lifting capacity of 3500 lb. Do not stand under generator while it is being lifted. Do not permit generator set to swing. Failure to observe these precautions can cause injury to personnel or damage to equipment.

- (3) Attach lifting equipment with a minimum lifting capacity of 3500 lb (1, figure 5-4) to both lifting eyes (2) on top edges of generator set (3). Insert a rope (4) through each of four tiedown rings (5) on generator set.
- (4) With one person at each rope to steady and guide generator set (3), lift generator set off of trailer.

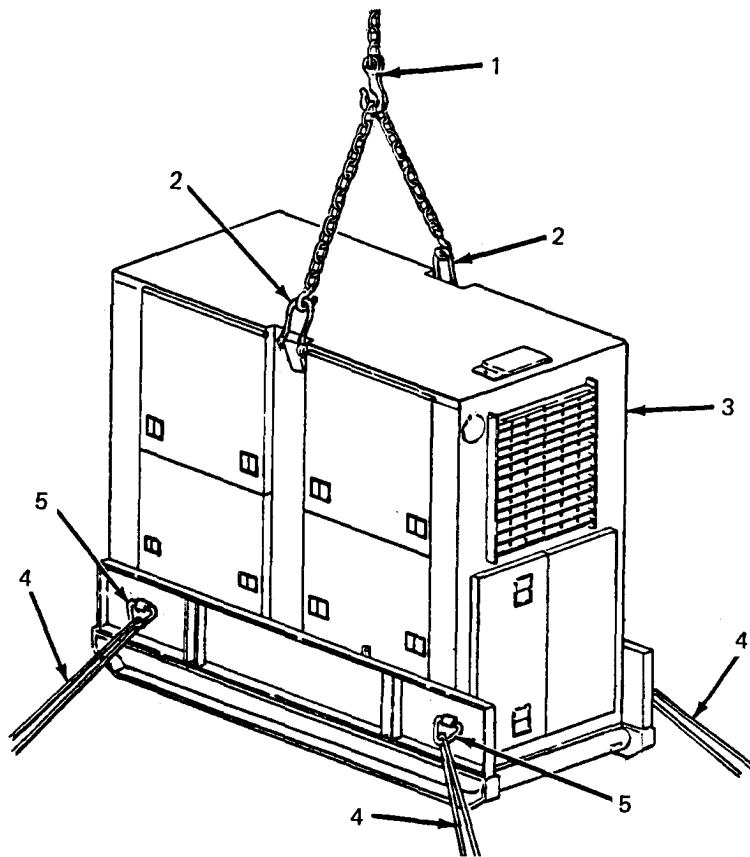

Figure 5-4. Lifting Generator Set.

*b. Installation.***WARNING**

When lifting generator set, use lifting equipment with a minimum lifting capacity of 3500 lb. Do not stand under generator set while it is being lifted. Do not permit generator set to swing. Failure to observe these precautions can cause injury to personnel or damage to equipment.

- (1) Attach lifting equipment with a minimum lifting capacity of 3500 lb (1, figure 5-4) to lifting eyes (2) on top edges of generator set (3). Insert a rope (4) through each of four tiedown rings (5) on generator set.
- (2) With one person at each rope to steady and guide generator set (3), lift generator set and carefully lower it onto trailer.
- (3) Insert four screws (4, figure 5-3) with beveled washers (5) down through generator set skids into trailer.
- (4) Working under trailer, install one lockwasher (6) and one nut (7) on each screw (4).
- (5) Position beveled washers (5) so that screw heads are parallel to tops of washers. While holding beveled washers in position, tighten hardware.
- (6) Connect generator set ground wire (1) to trailer GROUND TERMINAL stud (3).

Section IV. MAINTENANCE OF ELECTRICAL SYSTEM.

5-6. Power Cable Repair. (See figure 5-5.) The power plant cables are repaired by resoldering or replacing loose or damaged contacts inside the connector. A soldered contact can be unsoldered and a new one installed in its place. If, however, the damaged contact is crimped onto the wire, or if the wire is broken, the contact must be cut off. When one wire in the cable has been cut or broken, all wires must be cut to the same length and new contacts soldered on each. Refer to TB SIG 222 (TO 31-3-64) and TM 55-1500-323-25 (TO 1-1A-14).

*a. Removal.***NOTE**

Cable grip nut is left hand threaded. Turn clockwise to loosen.

- (1) Unscrew cable grip nut (1, figure 5-5) from housing (2).
- (2) Slide cable grip nut (1), packing gland (3) and collar (4) up cable (5) away from housing (2).
- (3) Remove three screws (6) and three washers (7) and separate housing (2) from plug shell (8).

- (4) Remove spacer (9) and insert (10) from plug shell (8).
- (5) Remove contact(s) (11) being repaired or replaced from spacer (9) and insert (10). Unsolder contact(s) (11) from wire(s) (12).

NOTE

If contact is crimped onto wire, or if wire is broken, do steps (6) through (8).

- (6) Cut contacts (11) off wires (12).
- (7) Strip back cable jacket to expose more of individual wires.
- (8) Cut wires to equal length. Strip and tin wires in accordance with procedures given in technical manuals referenced above.

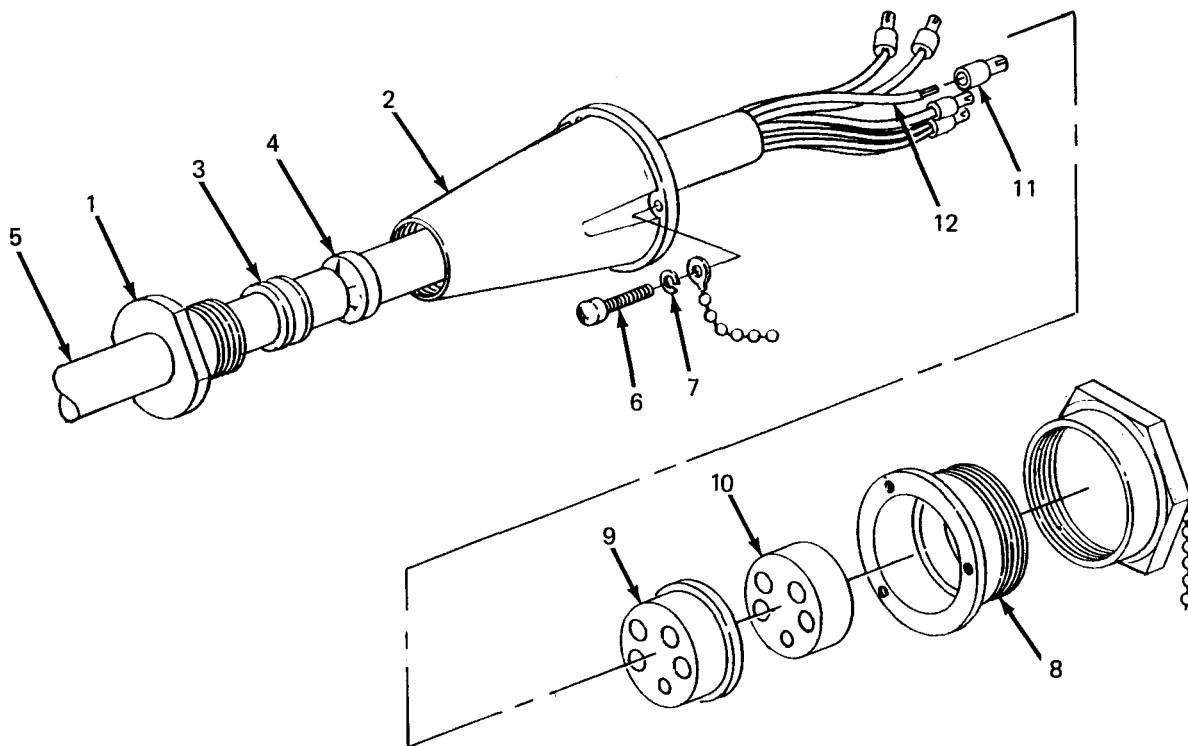

Figure 5-5. Power Cable Repair.

b. Installation.

- (1) Solder replacement contact(s) (11) on wire(s) (12).
- (2) Aline and insert contact(s) (11) into spacer (9) until contacts are fully seated.

- (3) Align insert (10) with plug shell (8) so key on insert matches keyway in plug shell and push insert into shell until it seats.
- (4) Align contacts (11) with corresponding holes in insert (10) and slide contacts into insert until spacer (9) is flush against insert (10).
- (5) Slide housing (2) up against plug shell (8) and secure with three screws (6) and three washers (7).
- (6) Slide collar (4) and packing gland (3) up cable (5) into housing (2).
- (7) Tighten cable grip nut (1) against housing (2).
- (8) Test cable for continuity (paragraph 4-27).

5-7. Switch Box Repair. The power plant switch box assembly is repaired by replacing defective components or by repairing individual wires within the switch box. Replacement of the switches is authorized only at the Intermediate direct support and general support levels of maintenance.

NOTE

All internal switch box wiring is labeled for identification with reference designations of its points of connection. If labeling has been removed, or is illegible, tag wires for identification before removing them.

a. Switch Replacement. (See figure 5-6.)

(1) Removal.

WARNING

To avoid risk of injury or death by electrocution, do not remove switch box rear cover while either power unit is still connected to switch box.

- (a)* Remove 18 screws (1, figure 5-6), 18 lockwashers (2), and 18 flat washers (3) securing rear cover (4) to switch box (5) and remove cover.
- (b)* Remove six nuts (6) and six lockwashers (7) securing wires (8) to switch (9) and slide wire terminals off threaded posts (10) on switch.
- (c)* Remove six screws (11), and six flat washers (12) securing switch (9) to switch box (13) and remove switch.

(2) Installation.

- (a)* Position switch (9) in switch box (13), making certain it is right side up, and secure with six screws (11) and six flat washers (12).
- (b)* Install seven wires (8) on switch (9) and secure with one nut (6) and one lockwasher (7) on each threaded post (10).
- (c)* Position rear cover (4) on switch box (5) and secure with 18 screws (1), 18 lockwashers (2), and 18 flat washers (3).

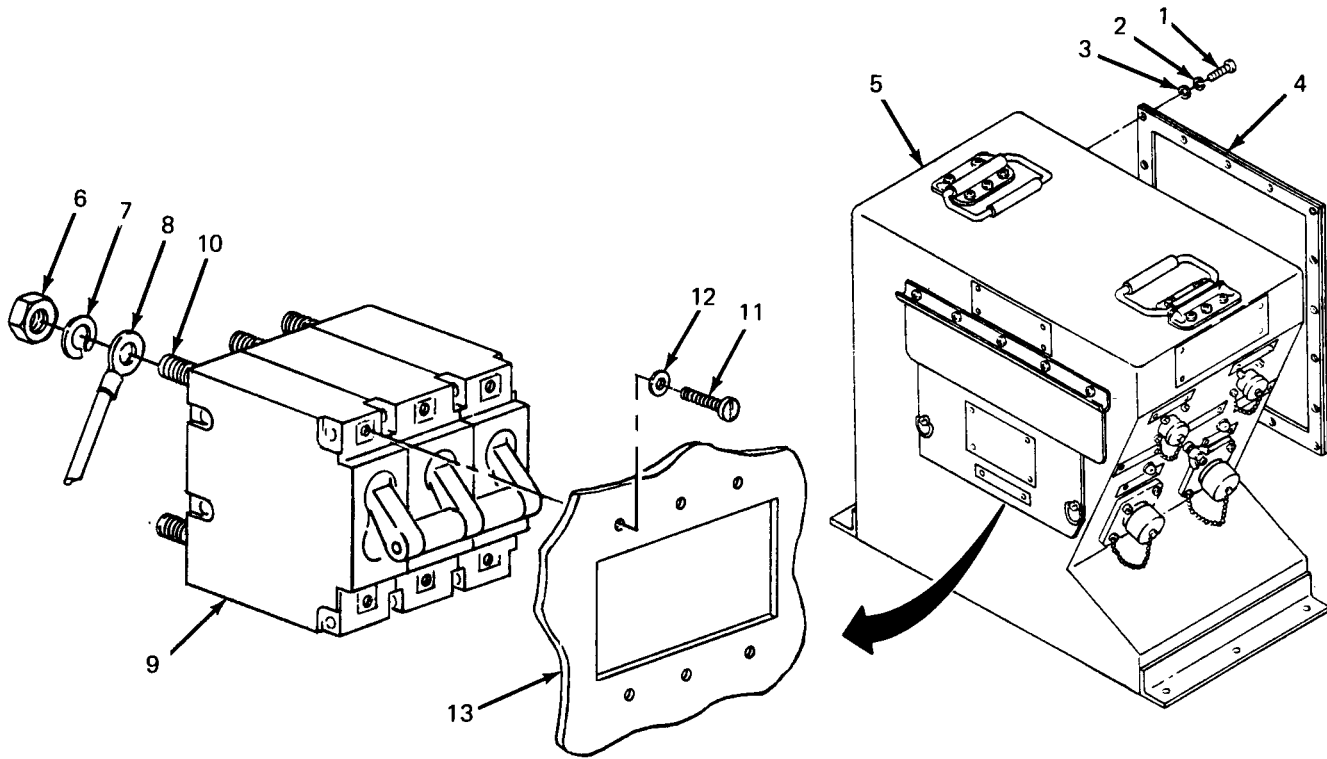

Figure 5-6. Switch Box Switch Replacement.

b. Wiring Repair. The switch box wiring is repaired by tightening or replacing loose or damaged terminals. The repair parts and special tools list in this manual lists part numbers for the terminals. The replacement terminals are soldered onto the wires in accordance with procedures given in TB SIG 222 (TO 31-3-64) and TM 55-1500-323-25 (TO 1-1A-14).

CHAPTER 6

TEST AND INSPECTION AFTER REPAIR

Section I. GENERAL REQUIREMENTS

6-1. General Requirements. The activity performing the repair is responsible for the performance of all applicable tests and inspections specified in the technical manuals referenced below. Activities performing maintenance on any component of the power plant must perform those tests and inspections required by the applicable component or system repair instruction.

Section II. INSPECTION

6-2. Generator Set Inspections. Refer to TM 5-6115-464-12 and -34 for inspections required following repair of the generator sets.

6-3. Trailer Inspections. Refer to TM 9-2330-205-14&P for inspections required following repair of the trailers.

Section III. OPERATIONAL TESTS

6-4. Generator Set Operational Tests. Refer to TM 5-6115-464-12 and -34 for operational tests required to verify satisfactory performance of the generator sets.

6-5. Trailer Operational Tests. Refer to TM 9-2330-205-14&P for operational tests required to verify satisfactory performance of the trailers.

APPENDIX A

REFERENCES

A-1. Scope. This appendix lists all pamphlets, forms, technical manuals, specifications and miscellaneous publications referenced in this manual.

A-2. Forms and Records.

Air Force Maintenance Management Program	AFM 66-1
Technical Order System Publication Improvement Report and Reply	AFTO Form 22
Recommended Changes to Publications and Blank Forms	DA Form 2028
Depreservation Guide for Vehicles and Equipment	DA Form 2258
Equipment Inspection and Maintenance Worksheet	DA Form 2404
Maintenance Request	DA Form 2407
Consolidated Index of Army Publications	DA PAM 25-30
The Army Maintenance Management System (TAMMS)	DA PAM 738-750
Product Quality Deficiency Report	SF 368

A-3. Military Specifications.

Chemical Agent Resistant Aliphatic Polyurethane Coating	MIL-C-46168
Identification Marking of U.S. Military Property	MIL-STD-130
Identification Marking of Combat and Tactical Transport	MIL-STD-642
Treatment and Painting of Materiel	MIL-T-704

A-4. Technical Manuals.

Operator and Organizational Maintenance Manual: Generator Set, Diesel Engine Driven, Tactical Skid Mounted, 15 KW, 3 Phase, 4 Wire; 120/208 and 240/416V (DOD Model MEP-004A) Utility Class, 50/60 Hz (NSN 6115-00-118-1241), (Model MEP-103A), Precise Class, 50/60 Hz (6115-00-118-1245), (Model MEP-113A), Precise Class, 400 Hz (6115-00-118-1244)	TM 5-6115-464-12
Organizational, Intermediate (Field) (Direct Support and General Support and Depot Maintenance Repair Parts and Special Tools List): Generator Set, Diesel Engine Driven, Tactical Skid Mounted, 15 KW, 3 Phase, 4 Wire, 120/208 and 240/416 V (DOD Models MEP-004A) Utility Class, 50/60 HZ (NSN 6115-00-118-1241); (Model MEP-103A), Precise Class, 50/60 HZ (6115-00-118-1245); (Model MEP-113A), Precise Class, 400 HZ (6115-00-118-1244)	TM 5-6115-464-24P
Intermediate (Field) Direct and General Support and Depot Level Maintenance Manual; Generator Set, Diesel Engine Driven, Tactical Skid Mtd, 15 KW, 3 Phase, 4 Wire, 120/208 and 240/416 Volts DOD Model MEP-004A, Utility Class, 50/60 HZ (NSN 6115-00-118-1241); Model MEP-103A, Precise Class, 50/60 HZ (6115-00-118-1245); Model MEP-113A, Precise Class, 400 HZ (6115-00-118-1244)	TM 5-6115-464-34
Installation Practices for Aircraft Electric and Electronic Wiring [TO 1-1A-14]	TM 55-1500-323-25

TM 5-6115-628-14&P

Procedures for Destruction of Equipment to Prevent Enemy
Use (Mobility Equipment Command) TM 750-244-3

Operator's, Organizational, Direct Support and General
Support Maintenance Manual Including Repair Parts and
Special Tools List for Chassis, Trailer, Generator, 2-1/2
Ton, 2-Wheel M200A1 (NSN 2330-00-331-2307) TM 9-2330-205-14&P

Organizational Direct Support, and General Support Care
Maintenance and Repair of Pneumatic Tires and
Inner Tubes TM 9-2610-200-24

Air Force Technical Order System TO-00-5-1

Painting and Marking of USAF Aerospace Ground Equipment TO 35-1-3

Processing and Inspection of Aerospace Ground Equipment
for Storage and Shipment TO 35-1-4

Processing and Inspection of Non-Mounted, Non-Aircraft
Gasoline and Diesel Engines for Storage and Shipment TO 38-1-5

A-5. Technical Bulletins.

Solder and Soldering [TO 31-3-64] TB SIG 222

Preservation of USAMECOM Mechanical Equipment for
Shipment and Storage TB 740-97-2

APPENDIX B

COMPONENTS OF END ITEM AND BASIC ISSUE ITEMS LISTS

Section I. INTRODUCTION

B-1. Scope. This appendix lists components of end item and basic issue items for the power plant to help you inventory items required for safe and efficient operation.

B-2. General. The Components of End Item and Basic Issue Items Lists are divided into the following sections:

a. Section II. Components of End Item. This listing is for informational purposes only, and is not authority to requisition replacements. These items are part of the end item, but are removed and separately packaged for transportation or shipment. As part of the end item, these items must be with the end item whenever it is issued or transferred between property accounts. Illustrations are furnished to assist you in identifying the items.

b. Section III. Basic Issue Items. These are the minimum essential items required to place the power plant in operation, to operate it, and to perform emergency repairs. Although shipped separately packaged, BII must be with the power plant during operation and whenever it is transferred between property accounts. The illustrations will assist you with hard-to-identify items. This manual is your authority to request/requisition replacement BII, based on TOE/MTOE authorization of the end item.

B-3. Explanation of Columns. The following provides an explanation of columns found in the tabular listings:

a. Column (1). Illustration Number (Illus No.). This column indicates the number assigned to the item.

b. Column (2). National Stock Number. Indicates the National stock number assigned to the item.

c. Column (3). Description. Indicates the federal item name and, if required, a minimum description to identify and locate the item. The last line for each item indicates the FSCM (in parentheses) followed by the part number.

If item needed differed for different models of this equipment, the model would be shown under the "Usable on Code" heading in this column. The Usable On Code is not applicable for this equipment.

d. Column (4). Unit of Measure (U/M). Indicates the measure used in performing the actual operational/maintenance function. This measure is expressed by a two-character alphabetical abbreviation (eg, ea, in, pr).

e. Column (5). Quantity Required (Qty Req'd). Indicates the quantity of the item authorized to be used with/on the equipment.

Section II. COMPONENTS OF END ITEM

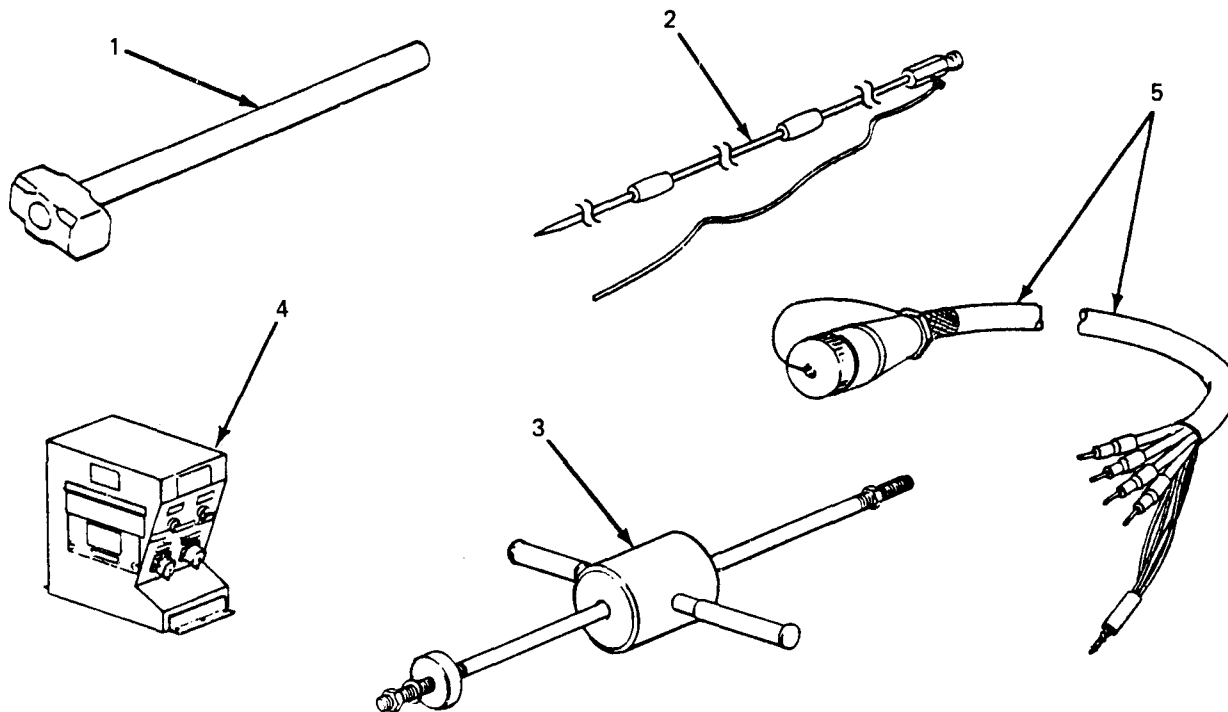

Figure B-1. Components of End Item.

(1) ILLUS/ ITEM NO.	(2) NATIONAL STOCK NUMBER	(3) DESCRIPTION CAGE AND PART NUMBER	Usable on code	(4) U/M	(5) QTY RQR
1	5120-00-243-2957	Hammer, Hand, Engineers 10 lb. (3.6 kg) (81348) GGG-H-86		EA	2
2	5975-00-878-3791	Rod, Ground, Driven, Sectional 9 ft (2.7 m) (81349) MIL-R-11461		EA	4
3	5120-01-013-1676	Hammer, Slide (97403) 13226E7741		EA	2
4	6120-01-090-2789	Switch Box (97403) 13220E6400		EA	1
5	6150-01-096-9024	Cable Assembly (97403) 13220E6427		EA	2

Section III. BASIC ISSUE ITEMS

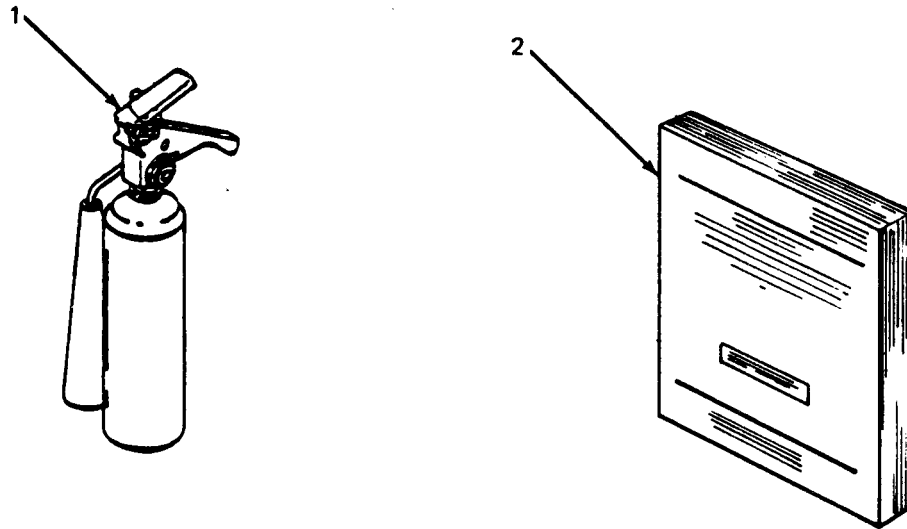

Figure B-2. Basic Issue Items.

(1) Illus no.	(2) National Stock Number	(3) Description FSCM And Part Number	(4) Usable On Code U/M	(5) Qty Req'd
1	4210-00-270-4512	Extinguisher, Fire, Hand, 5 lb. (2.3 kg) (81348) O-E-910	EA	2
2		Manual, Technical TM 5-6115-628-14&P	EA	1

APPENDIX C

MAINTENANCE ALLOCATION CHART

Section I. INTRODUCTION

C-1. General.

a. This section provides a general explanation of all maintenance and repair functions authorized at various maintenance levels.

b. Section II designates overall responsibility for the performance of maintenance functions on the identified end item or component. The implementation of the maintenance functions upon the end item or component will be consistent with the assigned maintenance functions.

c. Section III lists the tools and test equipment required for each maintenance function as referenced from Section II.

d. Section IV contains supplemental instructions, explanatory notes and/or illustrations required for a particular maintenance functions.

C-2. Explanation of Columns in Section II.

a. Group Number. Column 1. The assembly group is a numerical group assigned to each assembly in a top down breakdown sequence. The applicable assembly groups are listed on the MAC in disassembly sequence beginning with the first assembly removed in a top down disassembly sequence.

b. Assembly Group. Column 2. This column contains a brief description of the components of each assembly group.

c. Maintenance Functions. Column 3. This column lists the various maintenance functions (A through K) and indicates the lowest maintenance category authorized to perform these functions. The symbol designations for the various maintenance categories are as follows:

- C - Operator or crew
- O - Unit maintenance
- F - Intermediate direct support maintenance
- H - Intermediate general support maintenance
- D - Depot maintenance

The maintenance functions are defined as follows:

A - Inspect. To determine serviceability of an item by comparing its physical, mechanical, and electrical characteristics with established standards.

B - Test. To verify serviceability and to detect electrical or mechanical failure by use of test equipment.

C - Service. To clean, to preserve, to charge, and to add fuel, lubricants, cooling agents, and air. If it is desired that elements, such as painting and lubricating, be defined separately, they may be so listed.

D - Adjust. To rectify to the extent necessary to bring into proper operating range.

E - Aline. To adjust specified variable elements of an item to bring to optimum performance.

F - Calibrate. To determine the corrections to be made in the readings of instruments or test equipment used in precise measurement. Consists of the comparison of two instruments, one of which is a certified standard of known accuracy, to detect and adjust any discrepancy in the accuracy of the instrument being compared with the certified standard.

G - Install. To set up for use in an operational environment such as an emplacement, site, or vehicle.

H - Replace. To replace unserviceable items with serviceable like items.

I - Repair. Those maintenance operations necessary to restore an item to serviceable condition through correction of material damage or a specific failure. Repair may be accomplished at each category of maintenance.

J - Overhaul. Normally, the highest degree of maintenance performed by the Army in order to minimize time work in process is consistent with quality and economy of operation. It consists of that maintenance necessary to restore an item to completely serviceable condition as prescribed by maintenance standard in technical publications for each item of equipment. Overhaul normally does not return an item to like new, zero mileage, or zero hour condition.

K - Rebuild. The highest degree of material maintenance. It consists of restoring equipment as nearly as possible to new conditions in accordance with original manufacturing standards. Rebuild is performed only when required by operational considerations or other paramount factors and then only at the depot maintenance category. Rebuild reduces to zero the hours or miles the equipment, or component thereof, has been in use.

d. Symbols. The uppercase letter placed in the appropriate column indicates the lowest level at which that particular maintenance function is to be performed.

e. Tools and Equipment. *Column 4*. This column is provided for referencing by code, the special tools and test equipment, (Section III) required to perform the maintenance functions (Section II).

f. Remarks. *Column 5*. This column is provided for referencing by code, the remarks (Section IV) pertinent to the maintenance functions.

C-3. Explanation of Columns in Section III. Section III, Tools, Test, and Support Equipment Requirements is not applicable.

C-4. Explanation of Columns in Section IV. Section IV, Remarks, is not applicable.

Section II. MAINTENANCE ALLOCATION CHART

(1) Group no.	(2) Assembly group	(3) Maintenance functions											(4) Tools and equipment	(5) Remarks	
		A	B	C	D	E	F	G	H	I	J	K			
		Inspect	Test	Service	Adjust	Align	Calibrate	Install	Replace	Repair	Overhaul	Rebuild			
01	GENERATOR SET	O 0.2	0.5	C 2.0					F 3.0						See TM 5-6115-464-12, - 34 for generator set maintenance.
02	ELECTRICAL SYSTEM														
0201	Power Cables	C 0.1	O 0.3						C 0.1	F 1.0					
0202	Switch Box	C 0.1	O 0.5						O 0.5	F 2.0					
	Circuit Breaker		O 0.3						F 1.0						
	Connector	C 0.1							O 0.5						
	Load Terminals								O 0.5						
	Wiring	O 0.2	O 0.5						O 1.0	F 1.0					
03	ACCESSORIES														
	Sledge Hammer	C 0.1							C 0.1						
	Fire Extinguisher	C 0.1							C 0.1						
	Slide Hammer	C 0.1							C 0.1						
	Ground Rods	C 0.1							C 0.1						

TM 5-6115-628-14&P

(1) Group no.	(2) Assembly group	(3) Maintenance functions											(4) Tools and equipment	(5) Remarks	
		A	B	C	D	E	F	G	H	I	J	K			
		Inspect	Test	Service	Adjust	Align	Calibrate	Install	Replace	Repair	Overhaul	Rebuild			
04	TRAILER ASSEMBLY	C 0.5	O 1.0	C 0.5											See TM 9-2330-205-14&P for trailer assembly maintenance.
	Accessory Box							O 0.5	F 2.0						
	Fuel Can/Fire Extinguisher Brackets	C 0.1						O 0.5							
	Steps/Platforms	C 0.1						O 1.0	F 2.0						
	Fenders							O 1.0	F 2.0						
	Reflectors	C 0.1						O 0.5							
	Data Plates							O 0.2							
	Leveling Jack	C 0.1													
	Lighting	C 0.1	O 0.3					O 1.0	O 0.5						
	Handbrake	C 0.1													

APPENDIX D

UNIT, INTERMEDIATE (FIELD) (DIRECT SUPPORT AND GENERAL SUPPORT) AND DEPOT MAINTENANCE REPAIR PARTS AND SPECIAL TOOLS LIST

Section I. INTRODUCTION

D-1. Scope. This joint Army and Air Force manual lists repair parts and special tools required for the performance of unit, intermediate (field) (direct and general support), and depot maintenance of the power plant. The following paragraphs are keyed to applicable users. All users should read paragraph 4, Special Information, prior to using this manual.

D-2. General. Repair Parts and Special Tools List is divided into the following sections:

a. (ALL) Repair Parts – Section II. A list of repair parts authorized for the performance of maintenance at the unit, intermediate (field) (direct and general support), and depot level in figure and item number sequence.

b. (ALL) Special Tools, Test and Support Equipment – Section III. A list of special tools, test and support equipment authorized for the performance of maintenance at the unit, intermediate (field) (direct and general support), and depot level.

c. National Stock Number and Reference Number Index – Section IV. A list of National stock numbers in numerical sequence, followed by a list of reference numbers appearing in all the listings, in alphanumeric sequence, cross-referenced to the illustration figure number and item number.

d. Reference Designator Index – Section V. The reference Designator Column includes all assigned reference designators arranged first in alphabetical order, second in numeric order. Opposite each symbol is listed the figure and item number of the part in Section II and the reference number.

D-3. Explanation of columns. The following provides an explanation of columns in the tabular lists in Sections II and III.

a. (ALL) Illustrations, (Column 1). This column is divided as follows:

(1) *Figure Number.* Indicates the figure number of the illustration on which the item is shown.

(2) *Item Number.* Indicates the number used to identify the item on the illustration.

b. (ALL) Source, Maintenance, and Recoverability Codes (SMR), (Column 2).

(1) *Uniform Source Codes applicable to all Military Services.*

GENERAL: Source Codes are assigned to support items to indicate the manner of acquiring support items for maintenance, repair, or overhaul of end items. Source codes are entered in the first and second positions of the Uniform SMR Code format as follows:

Code	Definition
PA	Item procured and stocked for anticipated or known usage.
PB	Item procured and stocked for insurance purposes because essentiality dictates that a minimum quantity be available in the supply systems.
PC	Item procured and stocked and which otherwise would be coded PA except that it is deteriorative in nature.
PD	Support item, excluding support equipment, procured for initial issue or outfitting and stocked only for subsequent or additional initial issues or outfittings. Not subject to automatic replenishment.
PE	Support equipment procured and stocked for initial issue or outfittings to specified maintenance repair activities.
PF	Support equipment which will not be stocked but which will be centrally procured on demand.
PG	Item procured and stocked to provide for sustained support for the life of the equipment. It is applied to an item peculiar to the equipment which because of probable discontinuance or shutdown of production facilities would prove uneconomical to reproduce at a later time.
KD	An item of depot overhaul/repair kit and not purchased separately. Depot kit defined as a kit that provides items required at the time of overhaul or repair.
KF	An item of maintenance kit and not purchased separately. Maintenance kit defined as a kit that provides an item that can be replaced at unit or intermediate levels of maintenance.
KB	Item included in both a depot overhaul/repair kit and a maintenance kit.
MO	Item to be manufactured or fabricated at unit level.

Code	Definition
MF	Item to be manufactured or fabricated at intermediate maintenance levels. Air Force - Intermediate (*) Army - General Support (*)
MD	Item to be manufactured or fabricated at depot maintenance level.
AO	Item to be assembled at unit level.
AF	Item to be assembled at intermediate maintenance levels. Air Force - Intermediate (*) Army - Direct Support (*)
AH	Item to be assembled at intermediate maintenance levels. Air Force - Intermediate (*) Army - General Support (*)
AD	Item to be assembled at depot maintenance level.
XA	Item is not procured or stocked because the requirements for the item will result in the replacement of the next higher assembly.
XB	Item is not procured or stocked. If not available through salvage, requisition.
XB	Installation drawings, diagram, instruction sheet, field service drawing, that is identified by manufacturer's part number.
XD	A support item that is not stocked. When required, item will be procured through normal supply channels.

(*) **NOTE**

For USAF and the USA Safeguard Program, only Code "F" will be used to denote intermediate maintenance. On joint programs, use of either code F or H by the jointing service will denote intermediate maintenance to USAF and USA Safeguard Program.

(2) *Uniform Maintenance Codes applicable to all Military Services:* GENERAL Maintenance Codes are assigned to indicate the levels of maintenance authorized to USE and REPAIR support items. The Maintenance Codes are in the third and fourth position of the Uniform SMR Code Format.

(a) *Use (Third Position):* The Maintenance Code entered in the third position indicates the lowest level maintenance level authorized to remove, replace, and use the support item. The Maintenance Code entered in the third position indicates one of the following levels of maintenance.

Code	Application/Explanation
O	Support item is removed, replaced, used at the unit level of maintenance.
F	Support item is removed, replaced, used at the following intermediate levels: USAF - Intermediate (*) USA - Direct Support (*)
H	Support item is removed, replaced, used at the following intermediate levels: USAF - Intermediate (*) USA - General Support (*)

Code	Definition
D	Support items that are removed, replaced, used at Depot only: USAF - Depot, Mobile Depot and Specialized Repair Activity. USA - Depot, Mobile Depot and Specialized Repair Activity

(b) Repair (Fourth Position): The maintenance code entered in the fourth position indicates whether the item is to be repaired and identifies the lowest maintenance level with the capability to perform complete repair (i.e., all authorized maintenance functions).

O	The lowest maintenance level capable of complete repair of the support item is the unit level.
F	The lowest maintenance level capable of complete repair of the support item is the following intermediate level: USAF - Intermediate (*) USA - General Support (*)
H	The lowest maintenance level capable of complete repair of the support item is the following intermediate level: USAF - Intermediate (*) USA - General Support (*)

(*) NOTE

For USAF programs and the USA Safeguard Program, Code F will be used to denote intermediate maintenance. On joint programs, use of either Code F or H by the joining Service will denote intermediate maintenance to USAF and the USA Safeguard Program.

Code	Definition
D	The lowest maintenance level capable of complete repair of the support item is the depot level.

USAF - Depot, Mobile Depot, and Specialized Repair Activity.
 USA - Depot, Mobile Depot, and Specialized Repair Activity.

Code	Application/Explanation
L	Repair restricted to designated Specialized Repair Activity.
Z	Nonreparable. No repair is authorized.
B	No repair is authorized. The item maybe reconditioned by adjusting, lubricating, etc., at the user level. No parts or special tools are procured for the maintenance of this item.

(3) *Uniform Recoverability Codes applicable to all Military Services:* GENERAL Recoverability Codes are assigned to support items to indicate the disposition action on unserviceable items. The recoverability code is entered in the fifth position of the uniform SMR Code Format as follows:

Recoverability Codes	Definition
Z	Nonreparable item. When unserviceable, condemn and dispose at the level indicated in column 3.
O	Reparable item. When uneconomically reparable, condemn and dispose at unit level.
F	Reparable item. When uneconomically reparable, condemn and dispose at the following intermediate levels: USAF - Intermediate (*) USA - Direct Support (*)
H	Reparable item. When uneconomically reparable, condemn and dispose at the following levels: USAF - Intermediate (*) USA - General Support (*)

(*) NOTE

For USAF programs and the USA Safeguard Program, Code F will be used to denote intermediate maintenance. On joint programs, use of either Code F or H by the joining Service will denote intermediate level of USAF and the USA Safeguard Program.

Recoverability Codes	Definition
D	Reparable item. When beyond lower level repair capability, return to depot. Condemnation and disposal not authorized below depot level.
L	Reparable item. Repair, condemnation and disposal not authorized below depot/Specialized Repair Activity level.
A	Item requires special handling or condemnation procedure because of specific reasons (i.e., precious metal content, high-dollar value, critical material or hazardous material). Refer to appropriate manuals/directives for specific instructions.

c. (ALL) National Stock Number (Column 4). Indicates the National Stock Number assigned to the item and will be used for requisitioning purposes.

d. (ALL) Description (Column 5). Indicates the Federal item name and any additional descriptions of the item required. The abbreviation “w/e” when used as part of the nomenclature, indicates that the National Stock Number includes all armament, equipment, accessories and repair parts issued with the item. A part number or other reference number is followed by the applicable five digit Federal Supply Code for manufacturer in parentheses. If two reference numbers and Federal Supply Codes for manufacturer are listed, the first listing refers to the Department of Defense Drawing Number, the second listing refers to the actual part manufacturer. Items that are included in kits and sets are listed below the name of the kit or set with the quantity of each item in the kit or set indicated in the quantity incorporated in unit column.

e. (ALL) Unit of Measure (U/M) (Column 6). Indicates the standard of the basic quantity of the listed item as used in performing the actual maintenance function. This measure is expressed by a two-character alphabetical abbreviation (e.g., ea, in, pr, etc.). When the unit of measure differs from the unit of issue, the lowest unit of issue that will satisfy the required units of measure will be requisitioned.

f. (ALL) Quantity Incorporated in Unit (Column 7). Indicates the quantity of the item used in the assembly group. A “V” appearing in this column in lieu of a quantity indicates that a definite quantity cannot be indicated (e.g., shims, spacers, etc.).

D-4. Special Information.

a. (ALL) Identification of Usable On Codes for this Manual is not applicable.

b. Army unit maintenance personnel will extract the items which they require from Section II, 3rd or 4th position of column 2 of the intermediate direct and general support RPSTL. Parts which are manufactured or assembled at a higher level than that authorized to install the part are indicated by the use of higher level code in the source column.

c. Stockage Information.

(1) Air Force stockage information is contained in Initial Supply Support Lists issued separately from this publication by Sacramento Air Logistics Center in accordance with AFM 67-1, part 1, chapter 12.

- (2) Army stockage is demand based in accordance with AR 710-2. Repair parts listed in this publication represent those authorized for use at indicated maintenance levels and will be requisitioned on an as-required basis until stockage is justified in accordance with AR 710-2.

d. In the parts list, some items are indented to show that they are a component of the item under which they are indented.

D-5. How to Locate Repair Parts.

a. (ALL) When National Stock Number or reference number is unknown:

- (1) Using the table of contents, determine the functional group; i.e., batteries and related parts, exhaust and breather pipes, within which the repair part belongs. This is necessary since illustrations are prepared for functional groups.
- (2) Find the illustration covering the functional group to which the repair part belongs.
- (3) Identify the repair part on the illustration and note the illustration figure and item number of the repair part.
- (4) Using the Repair Parts Listing, find the figure and item number noted on the illustration.

b. (ALL) When national stock number or reference number is known:

- (1) Using the Index of National Stock Numbers and Reference Numbers, find the pertinent national stock number or reference number. This index is in ascending NSN sequence followed by a list of reference numbers in alphanumeric sequence, cross-referenced to the illustration figure number and item number.
- (2) After finding the figure and item number, locate the figure and item number in the repair parts list.

D-6. (F) Use of the Reference Designator Index Section. This Section (Section V) is used when the reference designator is known or identified by other technical manuals supporting this equipment. The reference number is given in this section. If description or location is desired, note the figure and item number. Turn to Section II to the noted figure and item number. The location of the part and description is given in this listing.

D-7. Abbreviations.

Abbreviations	Explanation
Not Applicable	

D-8. Federal Supply Codes for Manufacturers.

Code	Manufacturer
Not Applicable	

D-9. Recommendation for Maintenance Publication Improvements. Report of errors, omissions, and recommendations for improving this publication by the individual user is encouraged. Reports should be submitted as follows:

a. Air Force AFTO Form 22 in accordance with T.O. 00-5-1, directly to: Commander, Sacramento Air Logistics Center, ATTN: SM-ALC-MMEDTA, McClellan AFB, CA 95652-5609.

b. Army DA Form 2028, directly to: Commander, US Army Troop Support Command, ATTN: AMSTR-MCTS, 4300 Goodfellow Boulevard, St. Louis, MO 63120-1798.

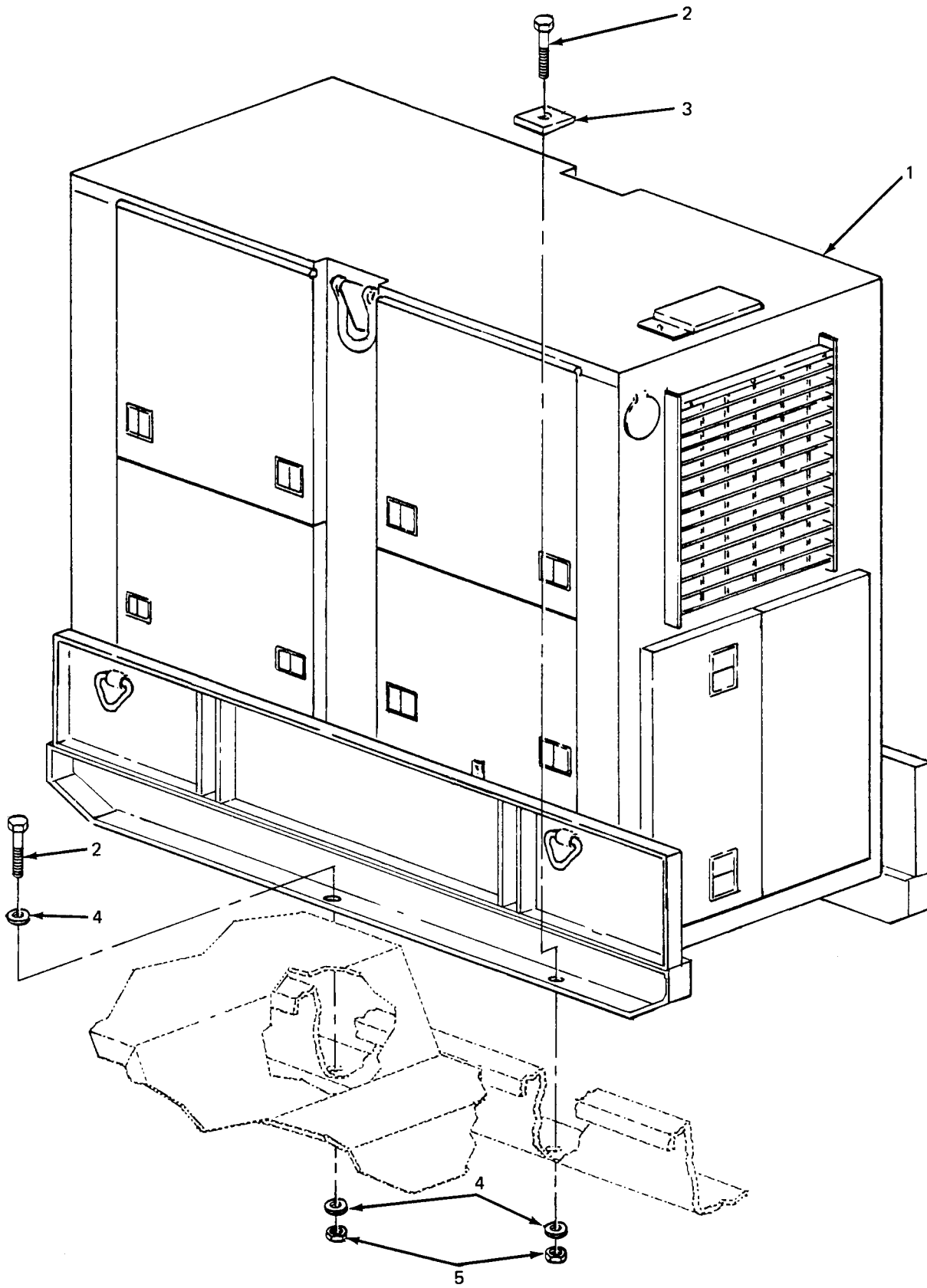

Figure D-1. Generator Set.

SECTION II

(1) ILLUS- TRATION		(2) SMR CODE				(3) USMC		(4)	(5) DESCRIPTION		(6)	(7)	(8)
a FIG NO	b TEN NO	a ARMY	b AIR FORCE	c NAVY	d USMC	a SSI	b R EPL ACTOF	NATIONAL STOCK NUMBER	REF NUMBER & MFR CODE	USABLE ON CODE	U/M	QTY INC IN UNIT	USMC QTY PER EQUIP
D-1	1	PDOHD						5115-00-118-1244	Group 01 - GENERATOR GENERATOR SET, DIESEL MEP-113A 30554		EA	2	
D-1	2	PAOZZ						5305-00-724-7222	SCREW, CAP, HEX MS90728-164 96906		EA	16	
D-1	3	PAFZZ						5310-01-185-0586	WASHER, BEVELED 13206 E4482-3 97403		EA	8	
D-1	4	PAOZZ						5310-00-823-8803	WASHER, FLAT MS27183-21 96906		EA	16	
D-1	5	PAOZZ						5310-00-269-4040	NUT, SELF-LOCKING MS51922-49 96906		EA	16	

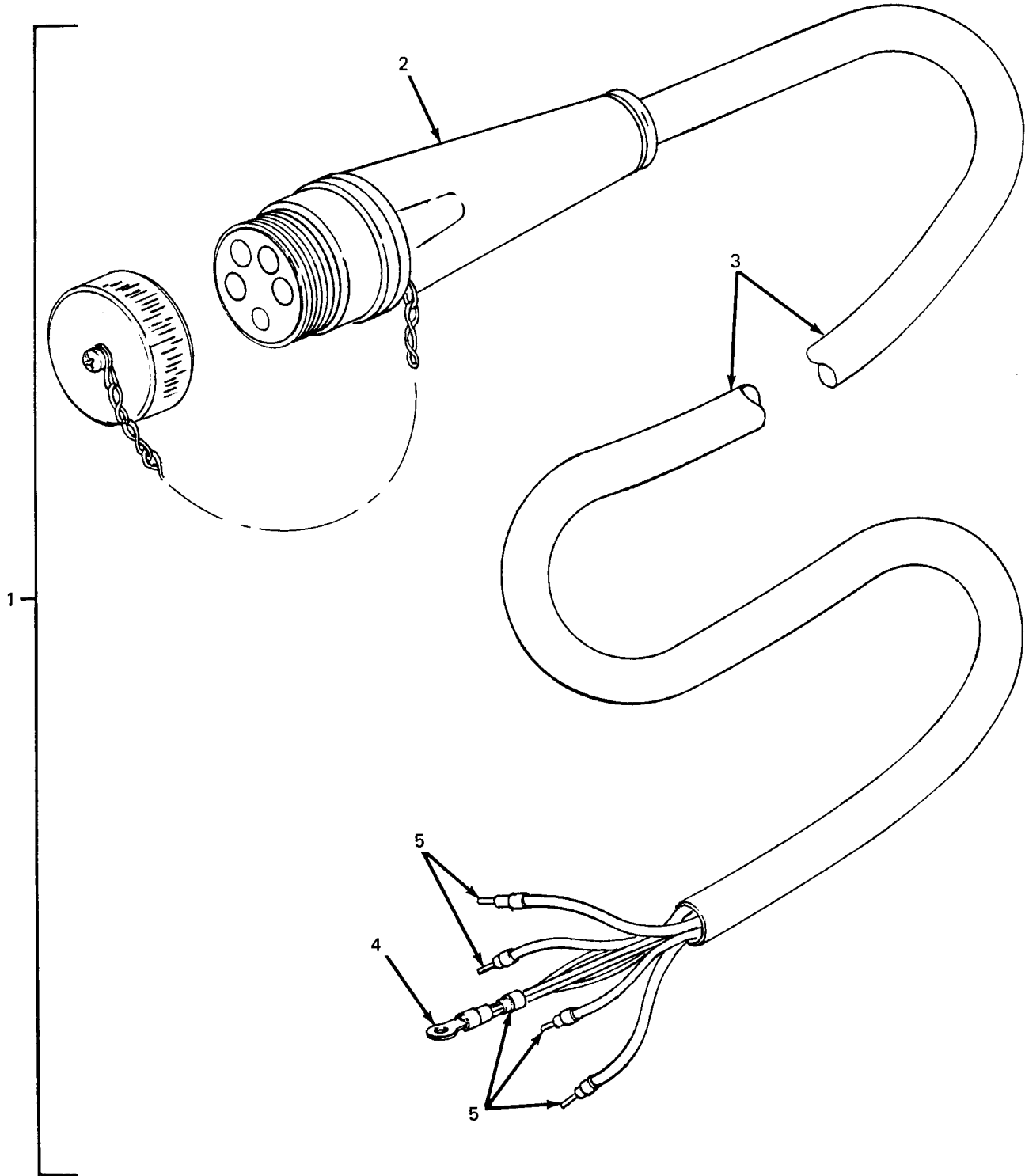

Figure D-2. Power Cables.

(1) ILLUS- TRATION		(2) SMR CODE				(3) USMC		(4)	(5) DESCRIPTION		(6)	(7)	(8)
a FIG NO	b ITEM NO	a ARMY	b AIR FORCE	c NAVY	d USMC	a SSI	b REPL ACTOR	NATIONAL STOCK NUMBER	REF NUMBER & MFR CODE	USABLE ON CODE	U/M	QTY INC IN JUNIT	USMC QTY PER EQUIP
D-2	1	MFOFZ						150-01-096-9024	Group 02 - ELECTRICAL SYSTEM 0201 - Power Cables CABLE ASSY 13220 E6427 97403		EA	2	
D-2	2	PAFZZ						935-01-154-2472	CONNECTOR, PLUG MS90557C- 32413S(Y) 96906		EA	2	
D-2	3	PAFZZ						145-01-038-5963	CABLE, POWER CO-04HDF 81349		EA	2	
D-2	4	PAFZZ						940-00-113-8190	TERMINAL, LUG MS25036-122 96906		EA	2	
D-2	5	PAFZZ							BAND, IDENTIFICATION MIL-P-15024/8 81349		EA	10	

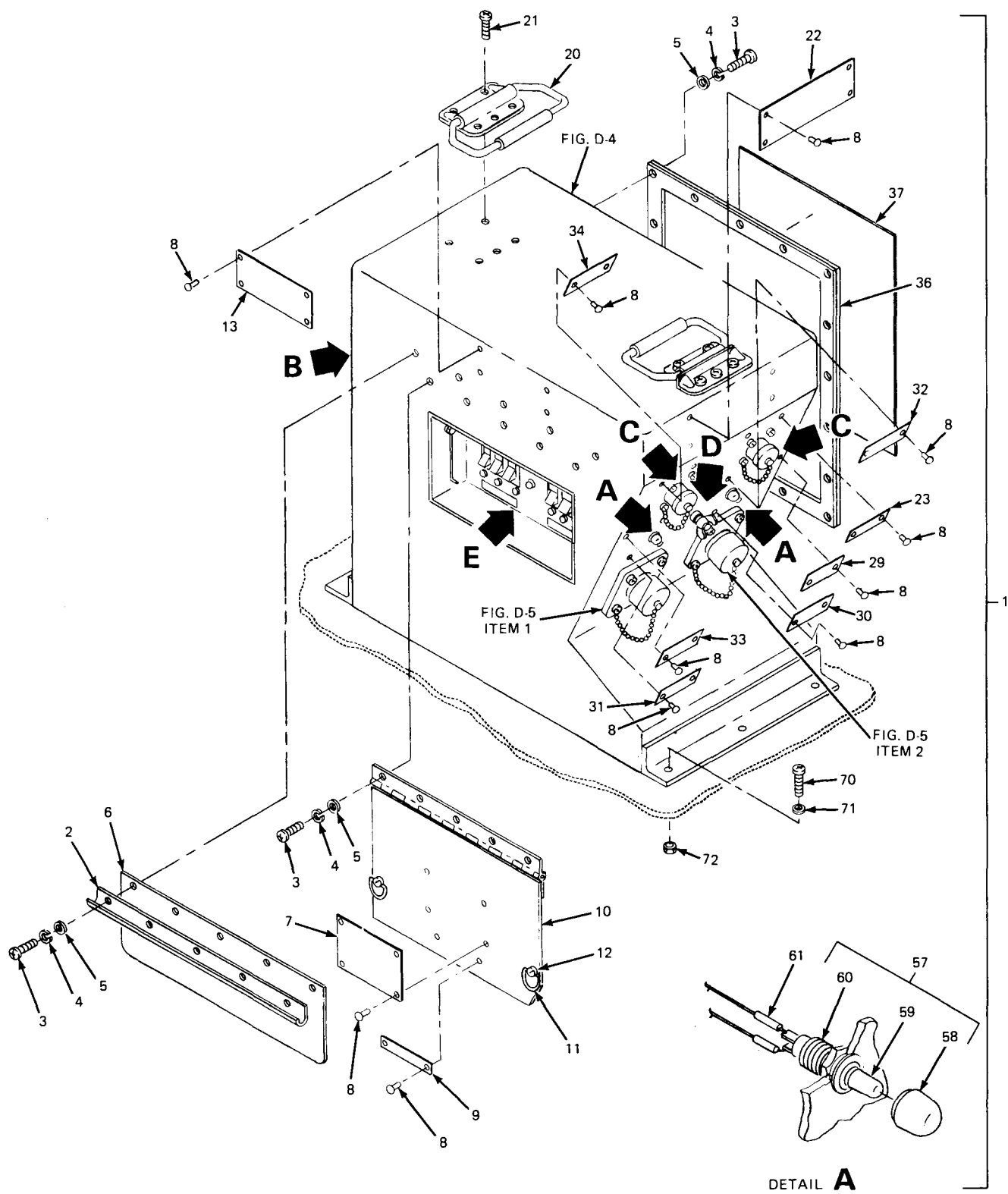

Figure D-3. Switch Box Assy (Sheet 1 of 3).

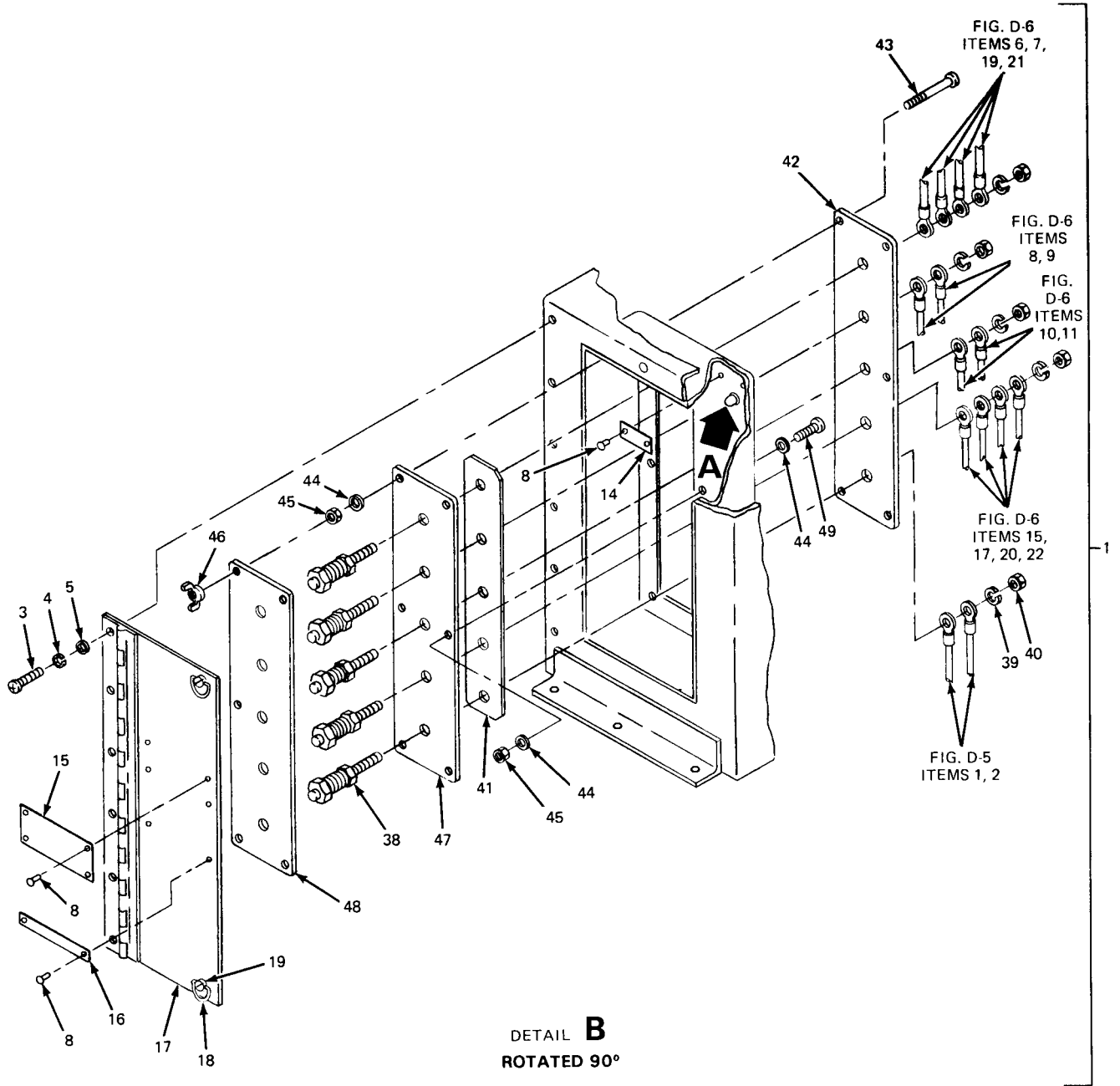

Figure D-3. Switch Box Assy (Sheet 2 of 3).

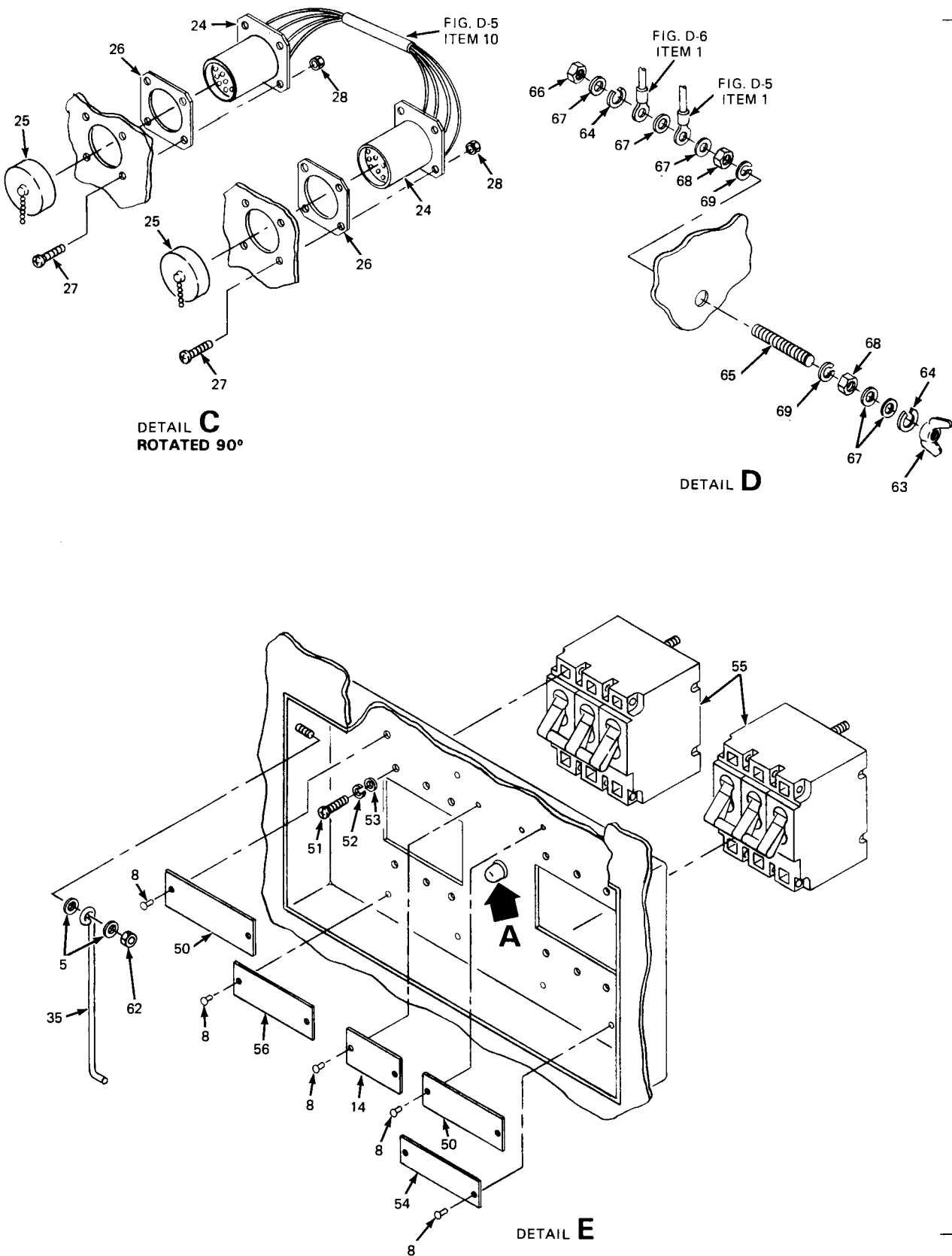

Figure D-3. Switch Box Assy (Sheet 3 of 3).

SECTION II

(1) ILLUSTRATION		(2) SMR CODE				(3) USMC		(4)	(5) DESCRIPTION		(6)	(7)	(8)
a. FIG NO.	b. TEM NO.	a. ARMY	b. AIR ORCE	c. IAVY	d. ISM	a. SSI	b. REPL ACTOR	NATIONAL STOCK	REF NUMBER & MFR NUMBER	USABLE ON CODE	J/M	QTY INC IN INITS	USMC QTY PER EQUIP
									0202 – Switch Box Assy				
D-3	1	PBOFF						3120-01-090-2789	SWITCH BOX ASSY 13220E6400	97403	EA	1	
D-3	2	XBFZZ							• CHANNEL, RAIN 13220E6422	97403	EA	1	
D-3	3	PAFZZ						3305-00-993-1848	• SCREW, MACHINE MS35207-265	96906	EA	34	
D-3	4	PAFZZ						3310-00-045-3296	• LOCKWASHER MS35338-43	96906	EA	34	
D-3	5	PAFZZ						3310-00-809-8546	• WASHER, FLAT MS27183-8	96906	EA	36	
D-3	6	XDFZZ							• SHIELD, RAIN 13220E6421	97403	EA	1	
D-3	7	XBOZZ							• PLATE, INSTRUCTION 13216E7579	97403	EA	1	
D-3	8	PAFZZ						3320-00-117-6815	• RIVET, SOLID MS20470 AD3-4	96906	EA	46	
D-3	9	MDFZZ							• PLATE, IDENTIFICATION 13220E6430	97403	EA	1	
D-3	10	XBFFF							• DOOR, SWITCH ACCESS 13220E6407	97403	EA	1	
D-3	11							3365-00-838-0422	• • RETAINER, QUARTER TURN FASTENER 13220E6406-2	97403	EA	2	
D-3	12	XDFZZ							• STUD, BAIL HEAD, QUARTER TURN 13220E6405	97403	EA	2	
D-3	13	MDFZZ							• PLATE, IDENTIFICATION 13220E6431	97403	EA	1	
D-3	14	MDFZZ							• PLATE, DESIGNATION 13220E6435	97403	EA	2	
D-3	15	MDFZZ							• PLATE, INSTRUCTION 13220E6433	97403	EA	1	
D-3	16	MDFZZ							• PLATE, IDENTIFICATION 13220E6434	97403	EA	1	
D-3	17	PAFFF						3115-01-B76-2182	• COVER, POWER OUTPUT 13220E6408	97403	EA	1	
D-3	18								• • RETAINER, QUARTER TURN FASTENER 13220E6406-1	97403	EA	2	
D-3	19								• • STUD, BAIL HEAD, QUARTER TURN 13220E6404	97403	EA	2	
D-3	20	XDOZZ						3340-00-801-2957	• HANDLE MS18012-5	96906	EA	2	

(1) ILLUS- TR/ ON		(2) SMR CODE				(3) USMC		(4)	(5) DESCRIPTION		(6)	(7)	(8)
a FIG NO	b ITEM NO	a ARMY	b AIR ORCE	c IAVY	d USMC	a ISI	b REPL ACTOR	NATIONAL STOCK NUMBER	REF NUMBER & MFR CODE	USABLE ON CODE	J/M	ITY NC IN NIT	USMC QTY PER EQUIP
									1202 - Switch Box Assy - CONT				
D-3	21	'AOZZ						1305-00-984-6194	SCREW, MACHINE MS35206-246 96906		EA	10	
D-3	22	(BOZZ							PLATE, INSTRUCTION 13218E5136 97403		EA	1	
D-3	23	'AFZZ							PLATE, INSTRUCTION 13214E1364 97403		EA	1	
D-3	24	'AOZZ							CONNECTOR, RECEPTACLE MS3102R18-4P 96906		EA	2	
D-3	25	'AOZZ						1935-01-175-8419	COVER, CONNECTOR MS25043-18DA 96906		EA	2	
D-3	26	'AFZZ						1330-00-079-7840	GASKET, RUBBER MS51007-6 96906		EA	2	
D-3	27	'AOZZ						1305-00-889-2999	SCREW, MACHINE MS35206-217 96906		EA	8	
D-3	28	'AOZZ						1310-00-088-0551	NUT, SELF-LOCKING MS21044N04 96906		EA	8	
D-3	29	'AFZZ							PLATE, DESIGNATION 13214E1360 97403		EA	1	
D-3	30	'AOZZ							PLATE, DESIGNATION 13214E1362 97403		EA	1	
D-3	31	'AOZZ							PLATE, DESIGNATION 13214E1361 97403		EA	1	
D-3	32	'AOZZ						1905-01-179-7336	PLATE, IDENTIFICATION 13217E2005 97403		EA	1	
D-3	33	'AOZZ							PLATE, DESIGNATION 13214E1359 97403		EA	1	
D-3	34	'AOZZ							PLATE, DESIGNATION 13214E1363 97403		EA	1	
D-3	35	XBOZZ							SUPPORT 13220E6410 97403		EA	1	
D-3	36	XBOZZ							COVER, REAR 13220E6409 97403		EA	1	
D-3	37	XBOZZ							WIRING DIAGRAM 13220E6425 97403		EA	1	
D-3	38								TERMINAL, LOAD 13218E5066-2 97403		EA	5	
D-3	39	'AOZZ						5310-00-948-9708	LOCKWASHER MS35335-93 96906		EA	5	
D-3	40	'AOZZ						5310-00-009-7694	NUT, PLAIN, HEX MS16203-67 96906		EA	5	
D-3	41	'AOZZ						5970-01-876-2191	FILLER, INSULATOR 13220E6417 97403		EA	1	

SECTION II

(1) ILLUS- TRATION		(2) SMR CODE				(3) USMC		(4)	(5) DESCRIPTION		(6)	(7)	(8)
a FIG NO	b ITEM NO	a ARMY	b AIR FORCE	c NAVY	d USMC	a SSI	b REPL ACTOP	NATIONAL STOCK NUMBER	REF NUMBER & MFR CODE	USABLE ON CODE	U/M	QTY INC IN JNIT	USMC QTY PER EQUIP
									0202 - Switch Box Assy - CONT				
D-3	42	PAOZZ						5970 -01-876-2327	. PANEL, INSULATOR 13220 E6416 97403		EA	1	
D-3	43	PAOZZ						5305-01-085-4495	SCREW, CAP 13220 E6436 97403		EA	5	
D-3	44	PAOZZ						5310-00-809-4058	. WASHER, FLAT MS27183-10 97403		EA	12	
D-3	45	PAOZZ						5310-00-997-1888	. NUT, PLAIN, HEX MS35649-2252 96906		EA	6	
D-3	46	PAOZZ						5310-00-080-8495	. NUT, PLAIN, WING MS35425-39 96906		EA	5	
D-3	47	PAOZZ						5970 -01-876-2192	. PANEL, INSULATOR 13220 E6415 97403		EA	1	
D-3	48	XBOZZ							. COVER, PROTECTIVE 13220 E6418 97403		EA	1	
D-3	49	PAOZZ						5305-00-068-0502	. SCREW, CAP, HEX MS90725-6 96906		EA	1	
D-3	50	MDOZZ							. PLATE, DESIGNATION 13220 E6432-1 97403		EA	2	
D-3	51	PAOZZ						5305 -00-984-4984	. SCREW, MACHINE MS35206-227 96906		EA	12	
D-3	52	PAOZZ						5310-00-045-4007	. LOCKWASHER MS35338-41 96906		EA	12	
D-3	53	PAOZZ						5310-00-082-1404	. WASHER, FLAT MS27183-6 96906		EA	12	
D-3	54	MDOZZ							. PLATE, DESIGNATION 13220 E6432-3 97403		EA	1	
D-3	55							5925-01-098-7829	. SWITCH 13220 E6428 97403		EA	1	
D-3	56	M0OZZ							PLATE, DESIGNATION 13220 E6432-2 97403		EA	1	
D-3	57	PAFZZ						6210-01-160-8026	. LIGHT, INDICATOR 13214 E1391 97403		EA	4	
D-3	58	PAOZZ							. . LENS, CLEAR 181-0937-003 72619		EA	4	
D-3	59	PAOZZ							. . LAMP G9B (GR) 58224		EA	4	
D-3	60	PAFZZ							. . HOUSING 181-8836-09- 553 72619		EA	4	
D-3	61								. SLEEVING, INSULATION MIL-I-23053/2 81349		EA	8	

(1) ILLUS- TRATION		(2) SMR CODE				(3) USMC		(4)	(5) DESCRIPTION		(6)	(7)	(8)
a FIG NO	b TEM NO	a ARMY	b AIR FORCE	c NAVY	d USMC	a SSI	b REPL FACTOR	NATIONAL STOCK NUMBER	REF NUMBER & MFR CODE	USABLE ON CODE	U/M	QTY INC IN UNIT	USMC QTY PER EQUIP
									1202 - Switch Box Assy - CONT				
D-3	62	PAOZZ						310-00-877-5797	NUT, SELF-LOCKING MS21044N3 96906		EA	8	
D-3	63	PAOZZ						310-00-543-4717	NUT, PLAIN, WING MS35425-28 96906		EA	1	
D-3	64	PAOZZ						310-00-184-8971	LOCKWASHER MS35338-103 96906		EA	2	
D-3	65	PAOZZ						307-00-227-1741	STUD 13214 E1223 97403		EA	1	
D-3	66	PAOZZ						310-00-584-7995	NUT, PLAIN, HEX MS16203-27 96906		EA	1	
D-3	67	PAOZZ						310-00-187-2413	WASHER, FLAT AN961-616T 81352		EA	5	
D-3	68	PAOZZ						310-01-026-5824	NUT, PLAIN, HEX MS16203-39 96906		EA	2	
D-3	69	PAOZZ						310-00-022-8847	LOCKWASHER MS35333-110 96906		EA	2	
D-3	70							305-00-225-3840	CREW, CAP, HEX MS90725-7 96906		EA	6	
D-3	71	PAOZZ						310-00-809-4058	WASHER, FLAT MS27183-10 96906		EA	12	
D-3	72	PAOZZ						310-00-088-1251	NUT, SELF-LOCKING MS51922-1 96906		EA	6	

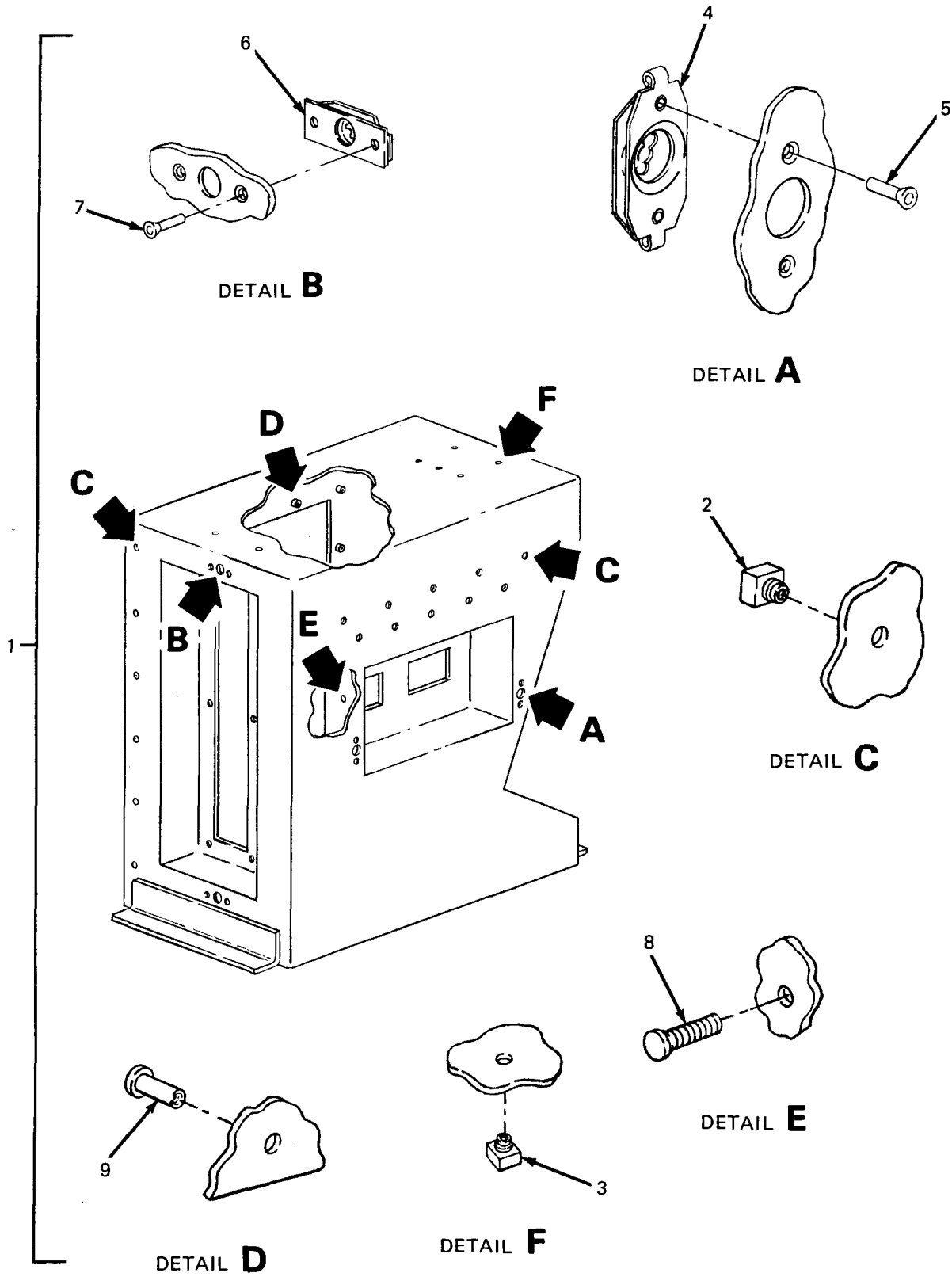

Figure D-4. Switch Box.

SECTION II

(1) ILLUSTRATION		(2) SMR CODE				(3) USMC		(4)	(5) DESCRIPTION			(7)	(8)
a FIG NO	b TEN NO	a ARMY	b AIR FORCE	c NAVY	d USMC	a SSI	b REPL FACTOR	NATIONAL STOCK NUMBER	REF NUMBER & MFR CODE	USABLE ON CODE	U/M	QTY INC IN UNIT	USMC QTY PER EQUIP
D-4	1	BOFF							1202 - Switch Box BOX, SWITCH 13220 E6401 97403		EA	1	
D-4	2	AFZZ						1310-01-875-1034	NUT, CLINCH 13211 E3895-5 97403		EA	23	
D-4	3	AFZZ							NUT, CLINCH 13211 E3895-3 97403		EA	10	
D-4	4							1325-00-282-7471	RECEPTACLE, QUARTER TURN 13220 E6403 97403		EA	2	
D-4	5	AFZZ							RIVET, SOLID MS20426DD4-6 96906		EA	4	
D-4	6							1325-00-788-5635	RECEPTACLE, QUARTER TURN 13220 E6402 97403		EA	2	
D-4	7	AFZZ							RIVET, SOLID MS20426DD3-5 96906		EA	4	
D-4	8								STUD, SELF-CLINCHING 13217 E1526-38 97403		EA	1	
D-4	9								NUT, PLAIN, BLIND RIVET MS27130-S100 96906		EA	18	

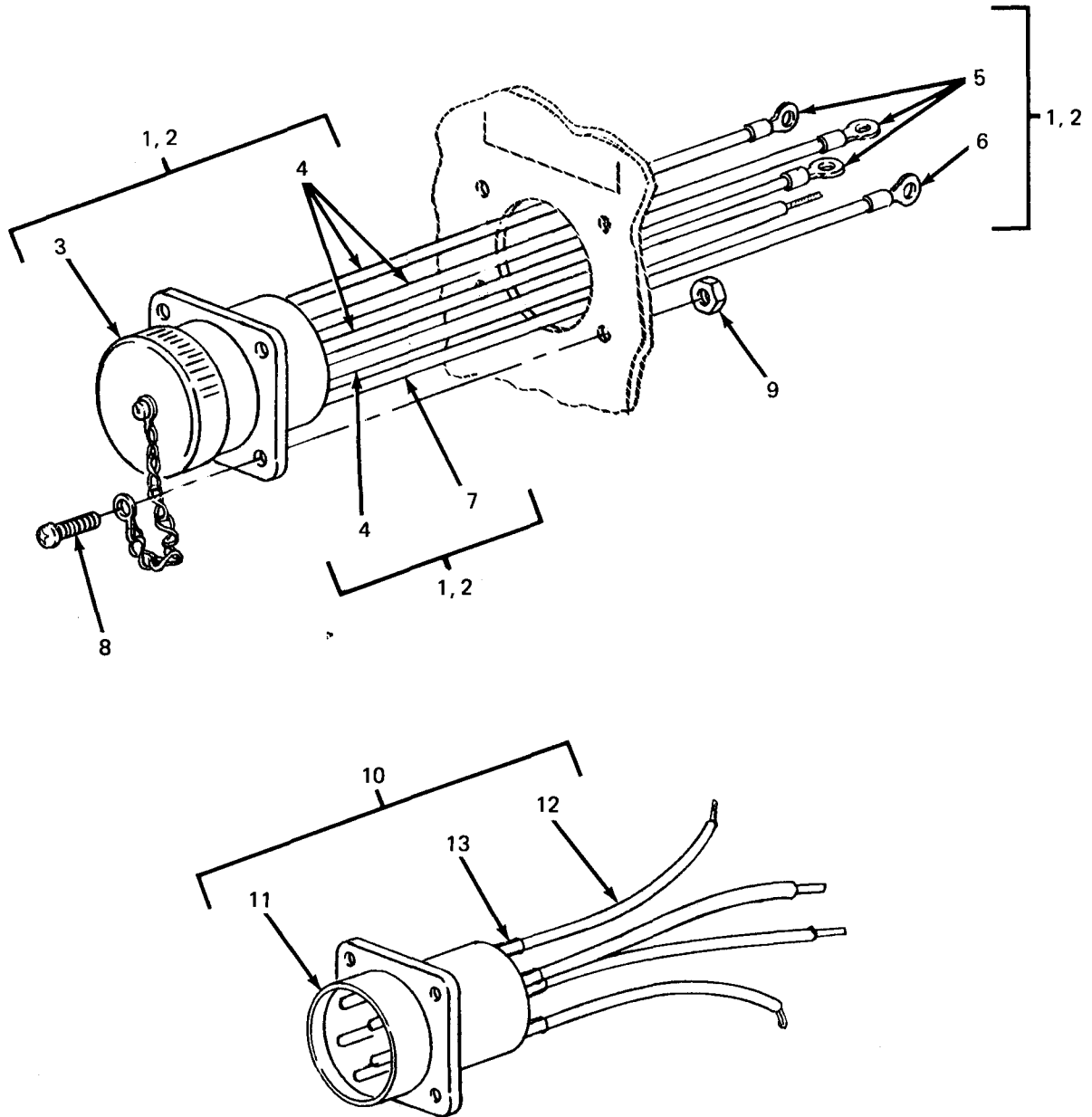

Figure D-5. Switch Box Cable Assemblies and Harness Assembly.

SECTION II

(1) ILLUS- TRATION		(2) SMR CODE				(3) USMC		(4)	(5) DESCRIPTION			(6)	(7)	(8)
a FIG NO	b TEN NO	a ARMY	b AIR FORCE	c NAVY	d USMC	a SSI	b REPL ACTOF	NATIONAL STOCK NUMBER	REF NUMBER & MFR CODE	USABLE ON CODE	U/M	QTY INC IN JNIT	USMC QTY PER EQUIP	
D-5	1	PAOFF						150-01 - 70-6968	202- Switch Box Cable Assemblies and Harness Assembly CABLE ASSY (GEN 1) 13220 E6419-1 97403		EA	1		
D-5	2	PAOFF						150-00- 70-6967	CABLE ASSY (GEN 2) 13220 E6419-2 97403		EA	1		
D-5	3	PAOZZ							CONNECTOR, RECEPTACLE MS90558C32413 96906		EA	2		
D-5	4	PAOZZ						145-00-578-6595	WIRE, ELECTRICAL M5086/2-4-9 81349		FT	AR		
D-5	5	PAOZZ						940-00-115-2677	TERMINAL, LUG MS20659-144 96906		EA	6		
D-5	6							940-00-113-8190	TERMINAL, LUG MS25036-122 96906		EA	2		
D-5	7	PAOZZ						145-00-578-6594	WIRE, ELECTRICAL M5086/2-6-9 81349		FT	AR		
D-5	8	PAOZZ						305-00-993-1848	CREW, MACHINE MS35207-265 96906		EA	8		
D-5	9	PAOZZ						310-00-877-5795	BUT, SELF-LOCKING MS21044N3 96906		EA	8		
D-5	10	PAOZZ							ARNESS ASSY 13220 E6426 97403		EA	1		
D-5	11							935-00-801-6617	CONNECTOR, RECEPTACLE MS3102R18-4P 96906		EA	1		
D-5	12	XDOZZ						145-00-578-7517	WIRE, SIZE 16 AWG M5086/1-16-9 81349		EA	4		
D-5	13								SLEEVING, INSULATION MIL-I-23053/ 5-106-4 81349		EA	4		

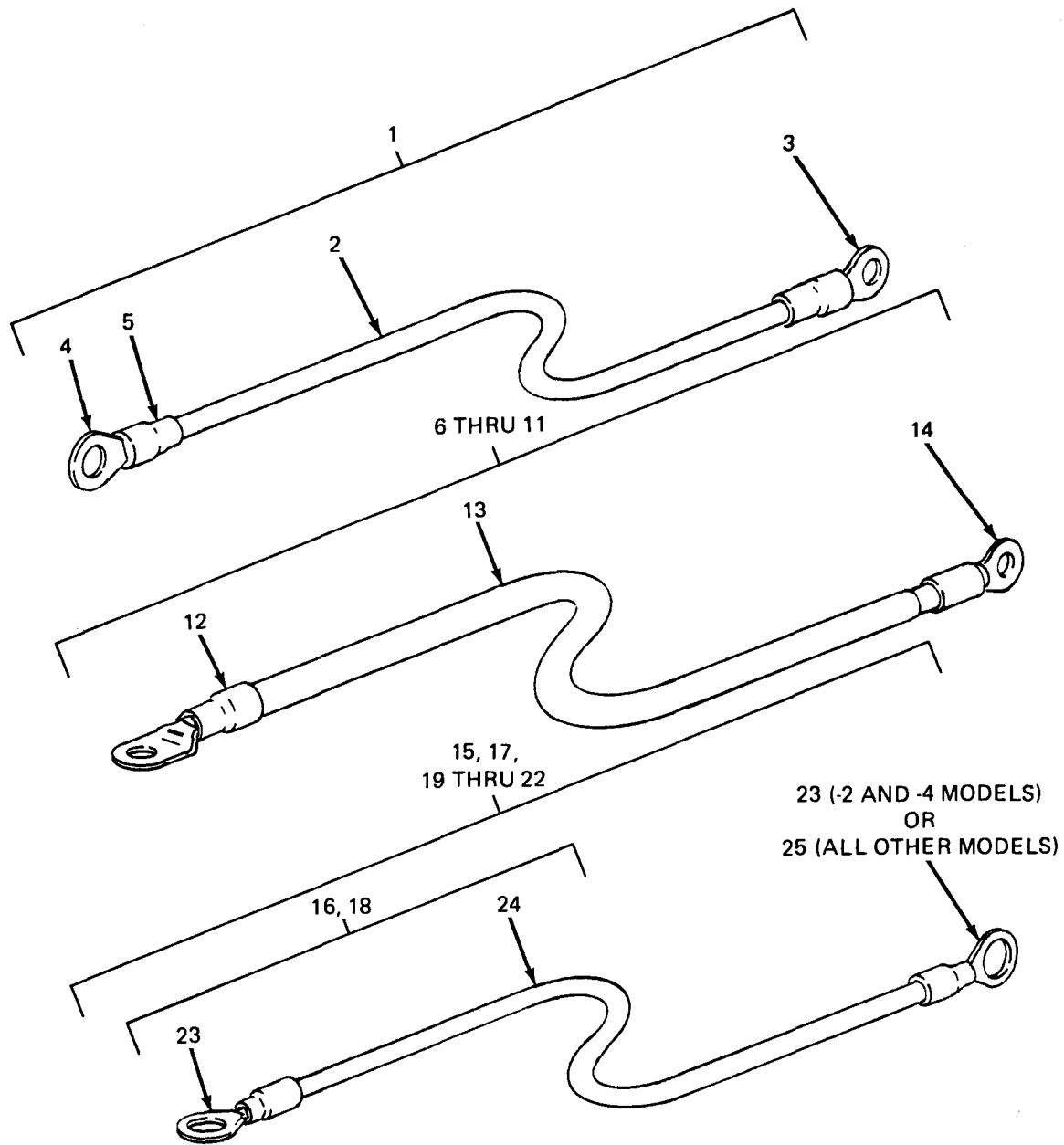

Figure D-6. Ground Wire Assembly and Electrical Leads.

SECTION II

(1) ILLUS- TRATION		(2) SMR CODE				(3) USMC		(4)	(5) DESCRIPTION		(6)	(7)	(8)
a FIG NO	b TEN NO	a ARMY	b AIR FORCE	c NAVY	d USMC	a SSI	b REPL ACTOR	NATIONAL STOCK NUMBER	REF NUMBER & MFR CODE	USABLE ON CODE	U/M	QTY INC IN INIT	USMC QTY PER EQUIP
D-6	1	MFFFF							0202 - Ground Wire Assembly and Electrical Leads WIRE ASSY, GROUND 13220 E6424 97403		FT	AR	
D-6	2	PAOZZ							. WIRE, SIZE 6 M5086/1-6-9 81349		EA	1	
D-6	3	PAOZZ						5940-00-113-8190	. TERMINAL, SIZE 6 MS25036-122 96906		EA	1	
D-6	4	PAOZZ						5940-00-115-2676	. TERMINAL, SIZE 6 MS20659-143 96906		EA	1	
D-6	5								. SLEEVING, INSULATION MIL-I-23053/5- 109-5 81349		EA	1	
D-6	6	MFFFF							LEAD, ELECTRICAL (L1 TO CB1-F) 13220 E6420-1 97403		EA	1	
D-6	7	PAFFF							LEAD, ELECTRICAL (L1 TO CB2-F) 13220 E6420-2 97403		EA	1	
D-6	8	PAFFF							LEAD, ELECTRICAL (L2 TO CB1-E) 13220 E6420-03 97403		EA	1	
D-6	9	PAFFF							LEAD, ELECTRICAL (L2 TO CB2-E) 13220 E6420-4 97403		EA	1	
D-6	10	PAFFF						5310-01-034-2835	LEAD, ELECTRICAL (L3 TO CB1-D) 13220 E6420-5 97403		EA	1	
D-6	11	PAFFF						5310-00-045-5214	LEAD, ELECTRICAL (L3 TO CB2-D) 13220 E6420-6 97403		EA	1	
D-6	12								. TERMINAL, LUG 13227 E127-1 97403		EA	6	
D-6	13	PAOZZ						5145-00-578-6595	. WIRE, ELECTRICAL M5086/2-4-9 81349		FT	AR	
D-6	14	PAOZZ						5940-00-115-2677	. TERMINAL, LUG MS20659-144 96906		EA	6	
D-6	15	MFOZZ							LEAD, ELECTRICAL (L0 TO DS1) 13220 E6423-1 97403		EA	1	
D-6	16	MFOZZ							LEAD, ELECTRICAL (CB1-C TO DS1) 13220 E6423-1 97403		EA	1	
D-6	17	MFFZZ							LEAD, ELECTRICAL (L0 TO DS2) 13220 E6423-3 97403		EA	1	
D-6	18								LEAD, ELECTRICAL (CB2C TO DS2) 13220 E6423-4 97403		EA	1	
D-6	19								LEAD, ELECTRICAL (L1 TO DS3) 13220 E6423-5 97403		EA	1	
D-6	20								LEAD, ELECTRICAL (L0 TO DS3) 13220 E6423-6 97403		EA	1	

(1) ILLUS- TRATION		(2) SMR CODE				(3) USMC		(4)	(5) DESCRIPTION		(7)	(8)	
a FIG NO	b TEN NO	a ARMY	b AIR FORCE	c NAVY	d USMC	a SSI	b REPL ACTOF	NATIONAL STOCK NUMBER	REF NUMBER & MFR CODE	USABLE ON CODE	U/M	QTY INC IN JNIT	USMC QTY PER EQUIP
D-6	21								1202 - Ground Wire Assembly and Electrical Leads - CONT EAD, ELECTRICAL (L1 TO DS4) 13220 E6423-7 97403		EA	1	
D-6	22	MFFFF							EAD, ELECTRICAL (LO TO DS4) 13220E6423-8 97403		EA	1	
D-6	23	PAOZZ						940-00-143-4773	TERMINAL, LUG MS25036-105 96906		EA	10	
D-6	24							145-00-578-7518	WIRE, 18 AWG M5086/1-18-9 81349		FT	AR	
D-6	25	PAFZZ						940-00-113-8185	TERMINAL, LUG MS25036-151 96906		EA	6	

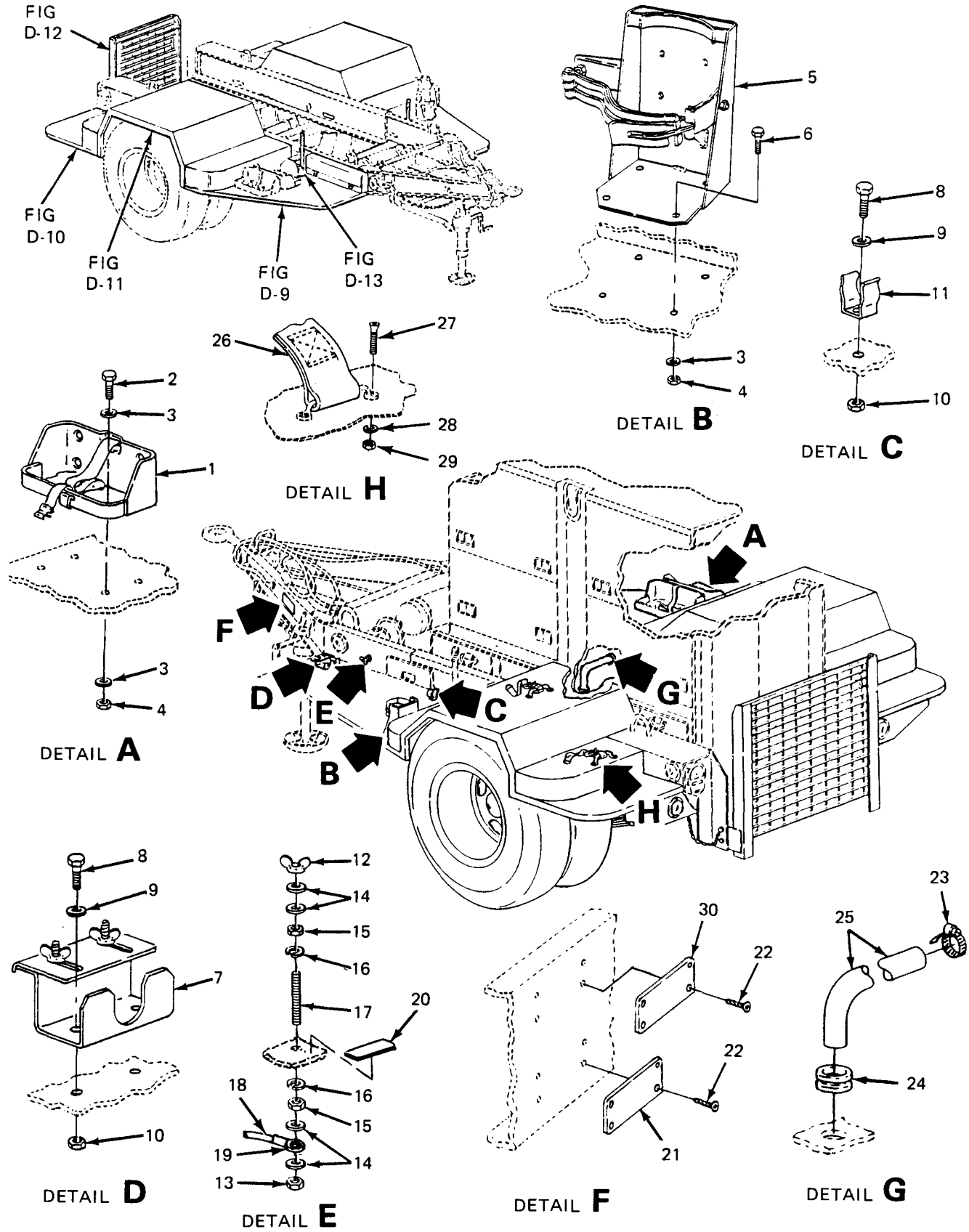

Figure D-7. Trailer Body.

SECTION II

(1) ILLUS- TRATION		(2) SMR CODE				(3) USMC		(4)	(5) DESCRIPTION		(6)	(7)	(8)
a FIG NO	b ITEM NO	a ARMY	b AIR FORCE	c NAVY	d USMC	a SSI	b REPL ACTOR	NATIONAL STOCK NUMBER	REF NUMBER & MFR CODE	USABLE ON CODE	U/M	QTY INC IN JNIT	USMC QTY PER EQUIP
									Group 04 - TRAILER 04 - Body				
D-7	1	PAOZZ							BRACKET ASSEMBLY LIQUID CONTAINER MS53052-1 96906	EA		4	
D-7	2	PAOZZ						5305-00-269-3213	SCREW, CAP, HEX MS90725-62 96906	EA		16	
D-7	3	PAOZZ						5310-00-080-6004	WASHER, FLAT MS27183-14 96906	EA		40	
D-7	4	PAOZZ						5310-00-087-4652	NUT, SELF-LOCKING MS51922-17 96906	EA		24	
D-7	5	PAOZZ						4210-00-223-4857	BRACKET, FIRE EXTINGUISHER 13214E1235 97403	EA		2	
D-7	6	PAOZZ						5305-00-984-5691	SCREW, MACHINE MS35206-311 96906	EA		8	
D-7	7	PAFFZ						5340-00-999-6277	BRACKET ASSEMBLY 13214 E1214 97403	EA		2	
D-7	8	PAOZZ						5305-00-068-0502	SCREW, CAP, HEX MS90725-6 96906	EA		6	
D-7	9	PAOZZ						5310-00-809-4058	WASHER, FLAT MS27183-10 96906	EA		6	
D-7	10	PAOZZ						5310-00-088-1251	NUT, SELF-LOCKING MS51922-1 96906	EA		6	
D-7	11	PAOZZ						5340-00-914-2578	CLIP, SPRING 13214 E1213-1 97403	EA		2	
D-7	12	PAOZZ						5310-00-543-4717	NUT, PLAIN, WING MS35425-28 96906	EA		2	
D-7	13	PAOZZ						5310-00-584-7995	NUT, PLAIN, HEX MS16203-27 96906	EA		2	
		PAOZZ						5310-00-187-2413	WASHER, FLAT AN961-616S 81352	EA		8	
D-7	14	PAOZZ						5310-01-004-9129	WASHER, FLAT AN961-616T 81352	EA		8	
D-7	15	PAOZZ						5310-01-026-5824	NUT, PLAIN, HEX MS16203-39 96906	EA		4	
D-7	16	PAOZZ						5310-00-022-8847	LOCKWASHER MS35333-110 96906	EA		4	
D-7	17	PAFZZ						5307-00-227-1741	STUD 13214 E1223 97403	EA		2	
D-7	18							6145-00-395-8799	WIRE, NO. 6 AWG QQ-W-343 81348	FT		AR	
D-7	19	PAOZZ						5940-00-115-4992	TERMINAL, LUG MS20659-110 96906	EA		4	
D-7	20	PAOZZ						9905-01-085-7703	PLATE, IDENTIFICATION 13205 E4918 97403	EA		2	

(1) ILLUS- TRATION		(2) SMR CODE				(3) USMC		(4)	(5) DESCRIPTION		(6)	(7)	(8)
a FIG NO	b ITEM NO	a ARMY	b AIR FORCE	c NAVY	d USMC	a SSI	b REPL ACTOR	NATIONAL STOCK NUMBER	REF NUMBER & MFR CODE	USABLE ON CODE	U/M	QTY INC IN UNIT	USMC QTY PER EQUIP
D-7	21	1D0ZZ							04 - Body - CONT PLATE, IDENTIFICATION 13216 E7604-37 97403		EA	2	
D-7	22	1A0ZZ						305-00-253-5615	SCREW, DRIVE MS21318-21 96906		EA	16	
D-7	23	1A0ZZ						730-00-908-3193	LAMP, HOSE MS35842-12 96906		EA	2	
D-7	24	1AFZZ						325-00-290-1960	WROMMET MS35489-27 96906		EA	2	
D-7	25	1F0ZZ							HOSE ZZ-H-428 81348		EA	2	
D-7	26	1AFFF							STRAP ASSY 13218 E5091 97403		EA	12	
D-7	27	1A0ZZ						305-00-984-7342	SCREW, MACHINE MS35191-274 96906		EA	24	
D-7	28	1A0ZZ						310-00-014-5850	WASHER, FLAT MS27183-42 96906		EA	24	
D-7	29	1A0ZZ						310-00-877-5797	BUT, SELF-LOCKING MS21044N3 96906		EA	24	
D-7	30	1D0ZZ							PLATE, IDENTIFICATION, MODIFICATION 13218E5119-6 97403		EA	2	

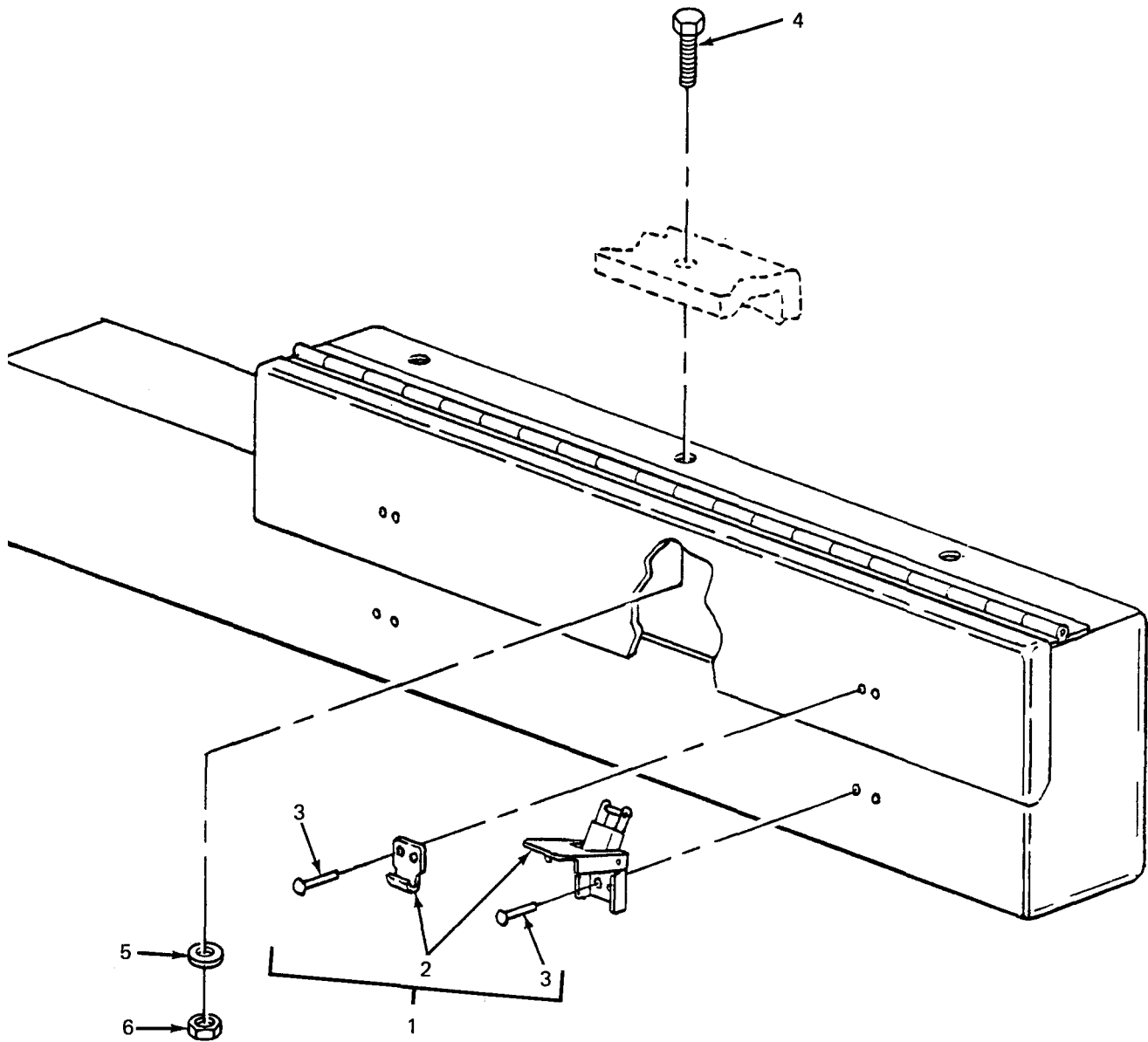

Figure D-8. Accessory Box.

SECTION II

(1) ILLUS- TRATION		(2) SMR CODE				(3) USMC		(4)	(5) DESCRIPTION		(6)	(7)	(8)
a FIG NO	b TEN NO	a ARMY	b AIR FORCE	c NAVY	d USMC	a SSI	b REPL ACTOF	NATIONAL STOCK NUMBER	REF NUMBER & MFR CODE	USABLE ON CODE	U/M	QTY INC IN UNIT	USMC QTY PER EQUIP
D-8	1	XBOZZ						450-00-903-3503	4 - Accessory Box ACCESSORY BOX 13214 E1256 97403		EA	2	
D-8	2	AFZZ						340-00-975-2126	LATCH AND STRIKE ASSEMBLY MS18015-1 96906		EA	4	
D-8	3	AFZZ						320-00-753-3830	RIVET MS20613-4P5		EA	16	
D-8	4	AOZZ						306-00-225-8498	CREW, CAP, HEX MS90725-33 96906		EA	6	
D-8	5	AOZZ						310-00-087-7493	WASHER, FLAT MS27183-13 96906		EA	6	
D-8	6	AOZZ						310-00-984-3806	BUT, SELF-LOCKING MS51922-9 96906		EA	6	

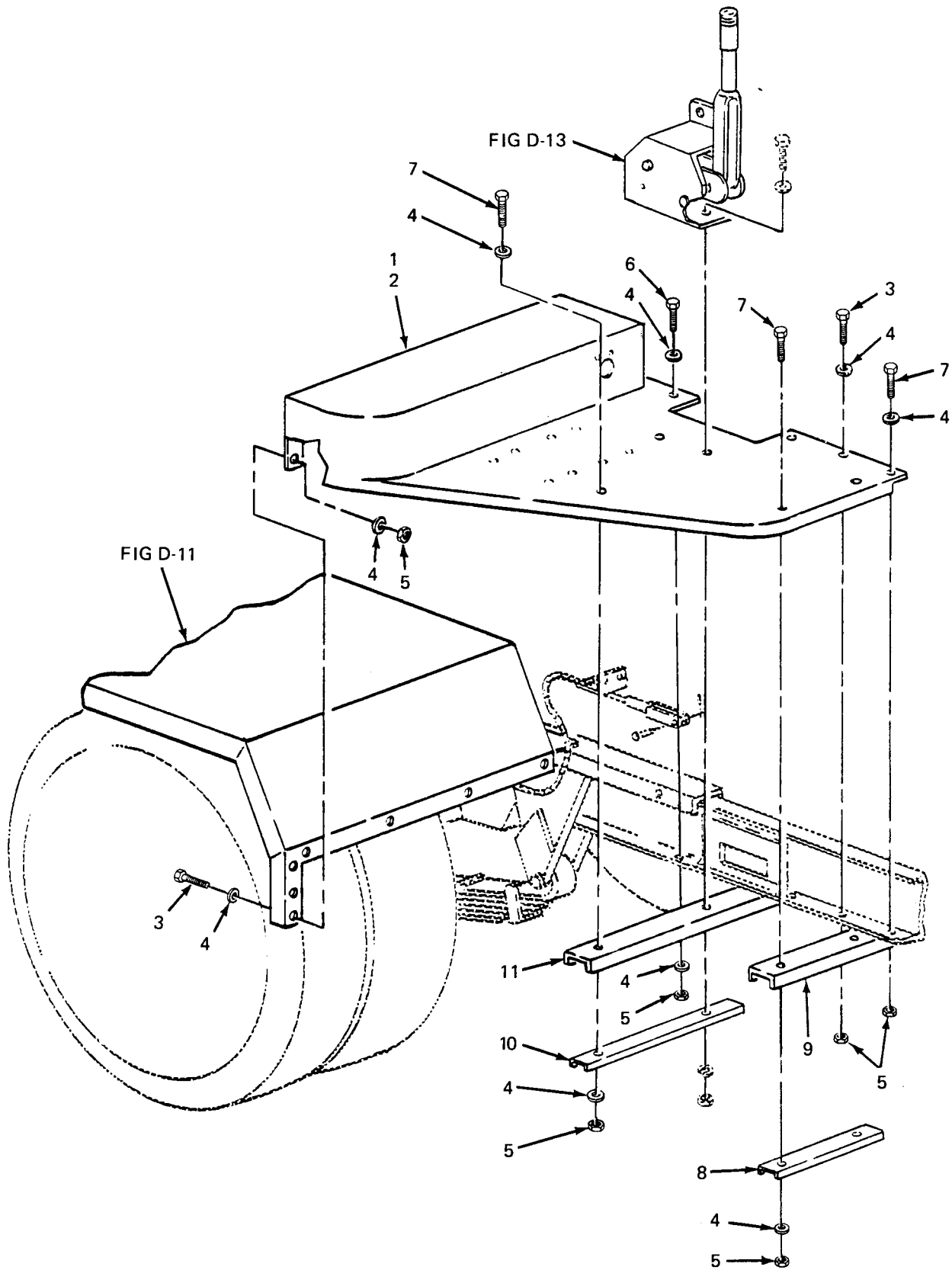

Figure D-9. Front Steps.

(1) ILLUS- TRATION		(2) SMR CODE				(3) USMC		(4)	(5) DESCRIPTION		(6)	(7)	(8)
a FIG NO	b EN IO	a ARMY	b AIR FORCE	c NAVY	d USMC	a SSI	b REPL FACTOR	NATIONAL STOCK NUMBER	REF NUMBER & MFR CODE	USABLE ON CODE	U/M	QTY INC IN INIT	USMC QTY PER EQUIP
D-9	1	XBOZZ						2330-01-150-9864	04 - Front Steps STEP, FRONT, CURBSIDE 13214 E1461 97403		EA	2	
D-9	2	XBFZZ						2510-01-196-4682	STEP, FRONT, ROADSIDE 13214E1462 97403		EA	2	
D-9	3	PDOFZ						3306-00-225-8499	SCREW, CAP, HEX MS90725-34 96906		EA	36	
D-9	4	PAOZZ						3310-00-081-4219	WASHER, FLAT MS27183-12 96906		EA	68	
D-9	5	PAOZZ						3310-00-984-3806	NUT, SELF-LOCKING MS51922-9		EA	68	
D-9	6	PAOZZ						3305-00-225-9081	SCREW, CAP, HEX MS90725-36 96906		EA	4	
D-9	7	PAOZZ						3306-00-225-8503	SCREW, CAP, HEX MS90725-39 96906		EA	20	
D-9	8	XBFZZ						3365-00-944-2692	SPACER 13214 E1267-1 97403		EA	4	
D-9	9	XBFZZ							CHANNEL 13214 E1268 97403		EA	2	
D-9	0	XBFZZ						3365-00-945-5998	SPACER 13214 E1267-2 97403		EA	4	
D-9	1	XBFZZ							CHANNEL 13214 E1463 97403		EA	2	
D-9	2	PAOZZ						3306-00-225-8503	SCREW, CAP, HEX MS90725-39 96906		EA	8	

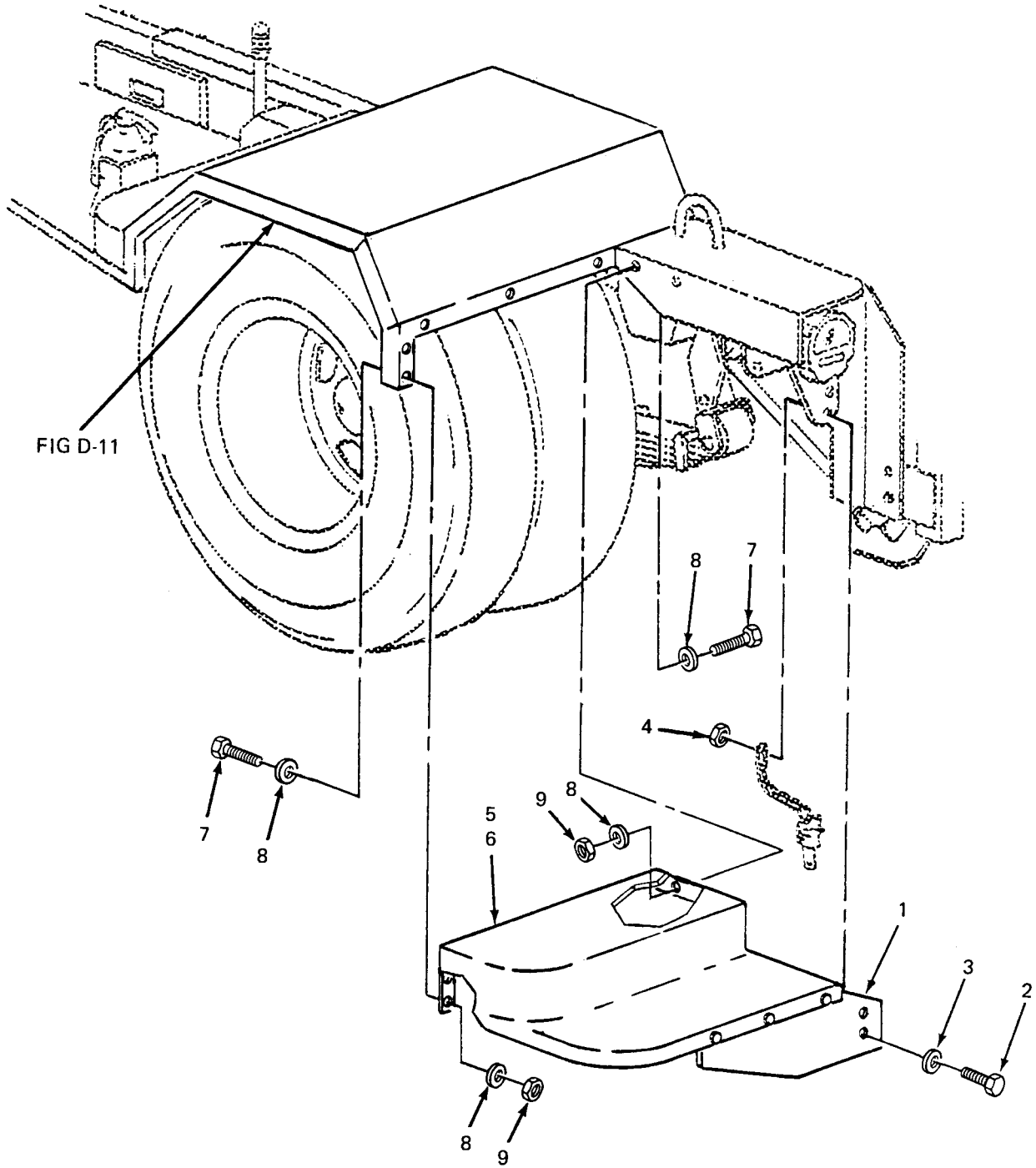

Figure D-10. Rear Steps.

SECTION II

(1) ILLUS- TRATION		(2) SMR CODE				(3) USMC		(4)	(5) DESCRIPTION	(6)	(7)	(8)	
a FIG NO	b ITEM NO	a ARMY	b AIR FORCE	c NAVY	d USMC	a SSI	b REPL FACTOF	NATIONAL STOCK NUMBER	REF NUMBER & MFR CODE	USABLE ON CODE	U/M	QTY INC IN UNIT	USMC QTY PER EQUIP
									J4 - Rear Steps				
D-10	1	XBOZZ						340-01-875-8820	BRACKET, STEP, REAR 13214 E1309-1	97403	EA	4	
D-10	2	PAOZZ						5305-00-269-3213	SCREW, CAP, HEX MS90725-62	96906	EA	12	
D-10	3	PAOZZ						5310-00-080-6004	WASHER, FLAT MS27183-14	96906	EA	12	
D-10	4	PAOZZ						5310-00-087-4652	NUT, SELF-LOCKING MS51922-17	96906	EA	12	
D-10	5	XBFZZ						2510-01-N73-0729	STEP, REAR, ROADSIDE 13214 E1261	97403	EA	2	
D-10	6	XBOZZ						2510-01-N73-0794	STEP, REAR, CURBSIDE 13214 E1259	97403	EA	2	
D-10	7	PDOFZ						5306-00-225-8499	SCREW, CAP, HEX MS90725-34	96906	EA	40	
D-10	8	PAOZZ						5310-00-081-4219	WASHER, FLAT MS27183-12	96906	EA	80	
D-10	9	PAOZZ						5310-00-984-3806	NUT, SELF-LOCKING MS51922-9	96906	EA	40	

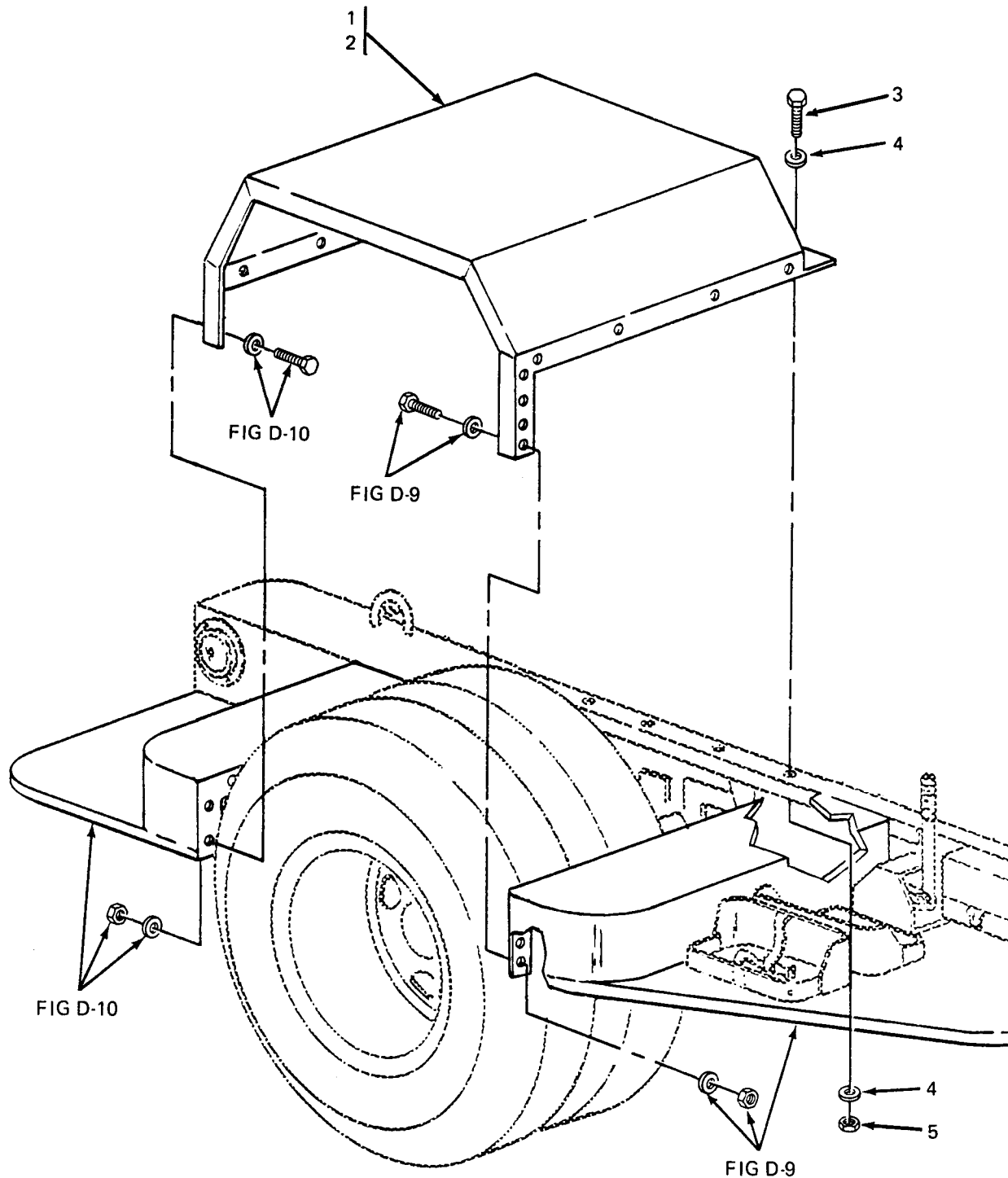

Figure D-11. Fenders.

SECTION II

(1) ILLUS- TRATION		(2) SMR CODE				(3) USMC		(4)	(5) DESCRIPTION		(6)	(7)	(8)
a FIG NO	b TEM NO	a ARMY	b AIR FORCE	c NAVY	d USMC	a SSI	b REPL ACTOF	NATIONAL STOCK NUMBER	REF NUMBER & MFR CODE	USABLE ON CODE	U/M	QTY INC IN JNIT	USMC QTY PER EQUIP
D-11	1	(BFZZ						2510-01-213-3242	04 - Fenders FENDER, ROADSIDE 13214 E1264	97403	EA	2	
D-11	2	(BFZZ						2510-01-195-4273	FENDER, CURBSIDE 13214 E1263	97403	EA	2	
D-11	3	'AOZZ						5306-00-225-8500	SCREW, CAP, HEX MS90725-35	96906	EA	20	
D-11	4	'AOZZ						5310-00-081-4219	WASHER, FLAT MS27183-12	96906	EA	40	
D-11	5	'AOZZ						5310-00-984-3806	NUT, SELF-LOCKING MS51922-9	96906	EA	20	

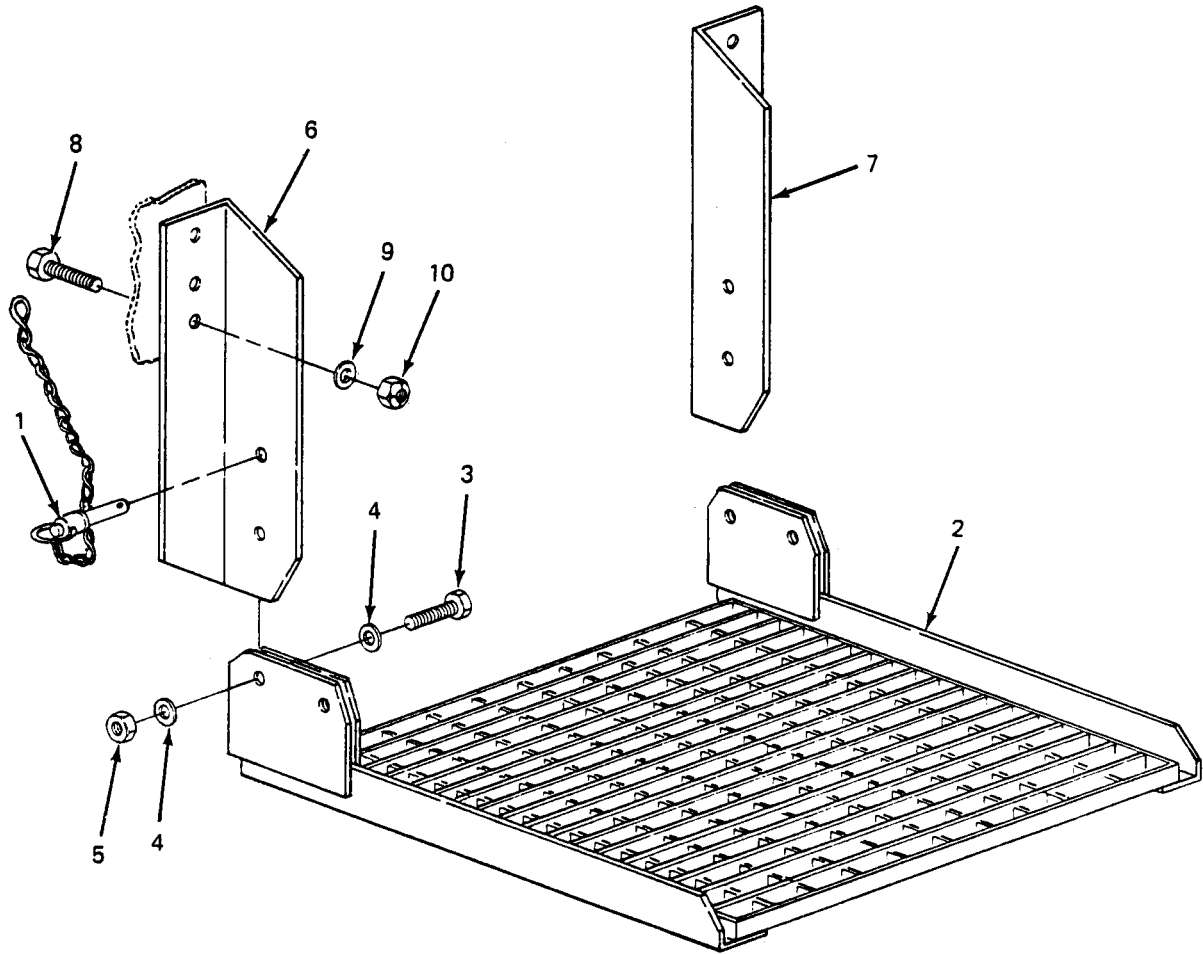

Figure D-12. Personnel Platform.

SECTION II

(1) ILLUS- TRATION		(2) SMR CODE				(3) USMC		(4)	(5) DESCRIPTION		(6)	(7)	(8)
a FIG NO	b ITEM NO	a ARMY	b AIR FORCE	c NAVY	d USMC	a SSI	b REPL ACTOR	NATIONAL STOCK NUMBER	REF NUMBER & MFR CODE	USABLE ON CODE	U/M	QTY INC IN UNIT	USMC QTY PER EQUIP
D-12	1	PAOZZ						340-01-156-6142	04 - Personnel Platform ANCHOR, PLATFORM 13214 D1303 97403		EA	4	
D-12	2	XBFZZ						510-00-926-3517	PLATFORM, PERSONNEL 13214 E1298 97403		EA	2	
D-12	3	PAOZZ						305-00-939-9204	SCREW, CAP, HEX MS90725-187 96906		EA	4	
D-12	4	PAOZZ						310-00-809-8533	WASHER, FLAT MS27183-23 96906		EA	8	
D-12	5	PAOZZ						310-00-067-6356	NUT, SELF-LOCKING MS51922-57 96906		EA	4	
D-12	6	XBFZZ						340-00-087-7676	BRACKET, LEFT 13214 E1299 97403		EA	2	
D-12	7							340-00-999-6441	BRACKET, RIGHT 13214 E1300 97403		EA	2	
D-12	8							305-00-042-6417	SCREW, CAP, HEX MS90725-113 96906		EA	12	
D-12	9	PAOZZ						310-00-809-5998	WASHER, FLAT MS27183-18 96906		EA	12	
D-12	10	PAOZZ						310-00-225-6993	NUT, SELF-LOCKING MS51922-33 96906		EA	12	

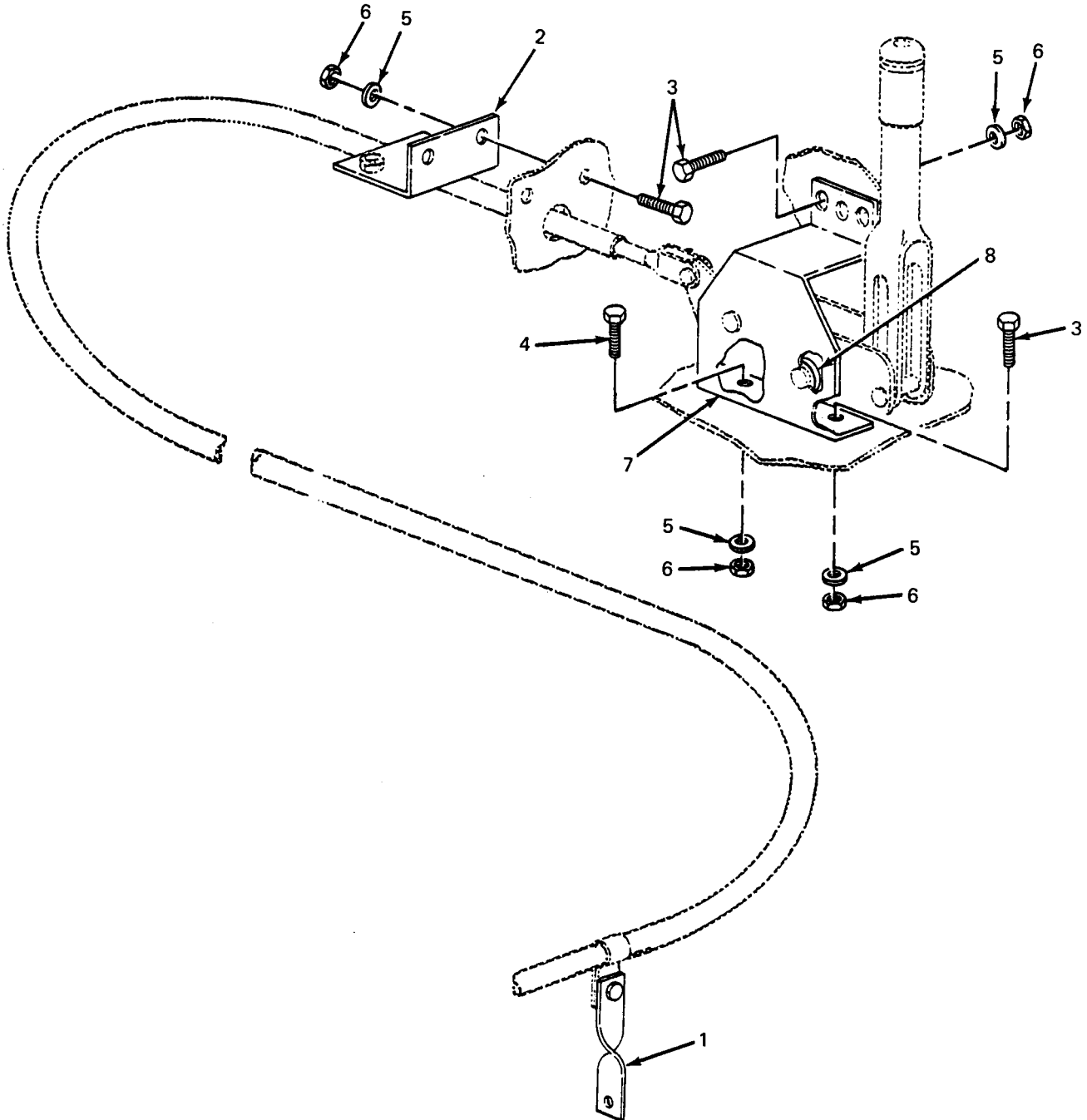

Figure D-13. Handbrakes.

(1) ILLUS- TRATION		(2) SMR CODE				(3) USMC		(4)	(5) DESCRIPTION		(6)	(7)	(8)
a FIG NO	b ITEM NO	a ARMY	b AIR ORCE	c NAVY	d USMC	a SI	b REPL ACTOR	NATIONAL STOCK NUMBER	REF NUMBER & MFR CODE	USABLE ON CODE	J/M	ITY NC IN INIT	JSMC QTY PER EQUIP
D-13	1	(BOZZ						115-01-876-2084	4 - Handbrakes TRAP, BRAKE CABLE 13214 E1271	97403	EA	4	
D-13	2								RACKET, BRAKE CABLE 13214 E1270	97403	EA	4	
D-13	3	PDOFZ						306-00-225-8499	CREW, CAP, HEX MS90725-34	96906	EA	20	
D-13	4	PAOZZ						5306-00-225-8503	SCREW, CAP, HEX MS90725-39	96906	EA	4	
D-13	5	PAOZZ						5310-00-081-4219	WASHER, FLAT MS27183-12	96906	EA	40	
D-13	6	PAOZZ						5310-00-984-3806	NUT, SELF-LOCKING MS51922-9	96906	EA	24	
D-13	7	XBOZZ						5340-01-226-5766	BRACKET, BRAKE 13214 E1269	96906	EA	4	
D-13	8	XBFZZ						5365-00-989-3304	SPACER 13214 E1272	97403	EA	8	

Section III. SPECIAL TOOLS, TEST AND SUPPORT EQUIPMENT

Not Applicable

Section IV. NATIONAL STOCK NUMBER AND REFERENCE NUMBER INDEX

NSN	Figure No.	Item No.	NSN	Figure No.	Item No.
2330-01-150-9864	D-9	1	5310-00-809-8533	D-12	4
2450-00-903-3503	D-8	1	5310-00-809-8546	D-3	5
2510-00-926-3517	D-12	2	5310-00-823-8803	D-1	4
2510-01-N73-0729	D-10	5	5310-00-877-5797	D-3	62
2510-01-N73-0794	D-10	6		D-5	9
2510-01-195-4273	D-11	2		D-7	29
2510-01-196-4682	D-9	2	5310-00-948-9708	D-3	39
2510-01-213-3242	D-11	1	5310-00-984-3806	D-8	6
4210-00-223-4857	D-7	5		D-9	5
4730-00-908-3193	D-7	23		D-10	9
5305-00-042-6417	D-12	8		D-11	5
5305-00-068-0502	D-3	49		D-13	6
	D-7	8	5310-00-997-1888	D-3	45
5305-00-225-3840	D-3	70	5310-01-B75-1034	D-4	2
5305-00-225-9081	D-9	6	5310-01-004-9129	D-7	14
5305-00-253-5615	D-7	22	5310-01-026-5824	D-3	68
5305-00-269-3213	D-7	2		D-7	15
	D-10	2	5310-01-034-2835	D-6	10
5305-00-724-7222	D-1	2	5310-01-185-0586	D-1	3
5305-00-889-2999	D-3	27	5320-00-117-6815	D-3	8
5305-00-939-9204	D-12	3	5320-00-753-3830	D-8	3
5305-00-984-4984	D-3	51	5325-00-282-7471	D-4	4
5305-00-984-5691	D-7	6	5325-00-290-1960	D-7	24
5305-00-984-6194	D-3	21	5325-00-788-5635	D-4	6
5305-00-984-7342	D-7	27	5325-01-077-3444	D-3	12
5305-00-993-1848	D-3	3	5330-00-079-7840	D-3	26
	D-5	8	5340-00-087-7676	D-12	6
5305-01-085-4495	D-3	43	5340-00-914-2578	D-7	11
5306-00-225-8498	D-8	4	5340-00-975-2126	D-8	2
5306-00-225-8499	D-9	3	5340-00-999-6277	D-7	7
	D-10	7	5340-00-999-6441	D-12	7
	D-13	3	5340-01-B75-8820	D-10	1
5306-00-225-8500	D-11	3	5340-01-156-6142	D-12	1
5306-00-225-8503	D-9	7	5340-01-226-5766	D-13	7
	D-9	12	5365-00-838-0422	D-3	11
	D-13	4	5365-00-944-2692	D-9	8
5307-00-227-1741	D-3	65	5365-00-945-5998	D-9	10
	D-7	17	5365-00-989-3340	D-13	8
5310-00-009-7694	D-3	40	5925-01-098-7829	D-3	55
5310-00-014-5850	D-7	28	5935-00-801-6617	D-5	11
5310-00-022-8847	D-3	69	5935-01-154-2472	D-2	2
	D-7	16	5935-01-175-8419	D-3	25
5310-00-045-3296	D-3	4	5940-00-113-8185	D-6	25
5310-00-045-4007	D-3	52	5940-00-113-8190	D-2	4
5310-00-045-5214	D-6	11		D-5	6
5310-00-067-6356	D-12	5		D-6	3
5310-00-080-6004	D-7	3	5940-00-115-2676	D-6	4
	D-10	3	5940-00-115-2677	D-5	5
5310-00-080-8495	D-3	46		D-6	14
5310-00-081-4219	D-9	4	5940-00-115-4992	D-7	19
	D-10	8	5940-00-143-4773	D-6	23
	D-11	4	5340-00-801-2957	D-3	20
	D-13	5	5970-01-B76-2191	D-3	41
5310-00-082-1404	D-3	53	5970-01-B76-2192	D-3	47
5310-00-087-4652	D-7	4	5970-01-B76-2327	D-3	42
	D-10	4	6115-00-118-1244	D-1	1
5310-00-087-7493	D-8	5	6115-01-B76-2084	D-13	1
5310-00-088-0551	D-3	28	6115-01-B76-2182	D-3	17
5310-00-088-1251	D-3	72	6120-01-090-2789	D-3	1
	D-7	10	6145-00-395-8799	D-7	18
5310-00-184-8971	D-3	64	6145-00-578-6594	D-5	7
5310-00-187-2413	D-3	67	6145-00-578-6595	D-5	4
	D-7	14		D-6	13
5310-00-225-6993	D-12	10	6145-00-578-7517	D-5	12
5310-00-269-4040	D-1	5	6145-00-578-7518	D-6	24
5310-00-543-4717	D-3	63	6145-01-038-5963	D-2	3
	D-7	12	6150-00-170-6967	D-5	2
5310-00-584-7995	D-3	66	6150-01-096-9024	D-2	1
	D-7	13	6150-01-170-6968	D-5	1
5310-00-809-4058	D-3	44	6210-01-160-8026	D-3	57
	D-3	71	9905-01-085-7703	D-7	20
	D-7	9	9905-01-179-7336	D-3	32
5310-00-809-5998	D-12	9			

Section IV. NATIONAL STOCK NUMBER AND REFERENCE NUMBER INDEX - CONT

Reference Number	FSCM	Fig. No.	Item No.	Reference Number	FSCM	Fig. No.	Item No.
AN961-616S	81352	D-7	14	MS51922-1	96906	D-7	10
AN961-616T	81352	D-3	67	MS51922-9	96906	D-8	6
		D-7	14			D-9	5
CO-04HDF	81349	D-2	3			D-10	9
G9B(GR)	58224	D-3	59			D-11	5
MEP-113A	30554	D-1	1			D-13	6
MIL-I-23053/2	81349	D-3	61	MS51922-17	96906	D-7	4
MIL-I-23053/ 5-106-4	81349	D-5	13			D-10	4
MIL-I-23053/ 5-109-5	81349	D-6	5	MS51922-33	96906	D-12	10
MIL-P-15024/8	81349	D-2	5	MS51922-49	96906	D-1	5
MS16203-27	96906	D-3	66	MS51922-57	96906	D-12	5
		D-7	13	MS53052-1	96906	D-7	1
MS16203-39	96906	D-3	68	MS90557C-	96906	D-2	2
		D-7	15	32413S(Y)			
MS16203-67	96906	D-3	40	MS90558C32413	96906	D-5	3
MS18012-5	96906	D-3	20	MS90725-6	96906	D-3	49
MS18015-1	96906	D-8	2			D-7	8
MS20426DD3-5	96906	D-4	7	MS90725-7	96906	D-3	70
MS20426DD4-6	96906	D-4	5	MS90725-33	96906	D-8	4
MS20470AD3-4	96906	D-3	8	MS90725-34	96906	D-9	3
MS20613-4P5		D-8	3			D-10	7
MS20659-110	96906	D-7	19	MS90725-35	96906	D-11	3
MS20659-143	96906	D-6	4	MS90725-36	96906	D-9	6
MS20659-144	96906	D-5	5	MS90725-39	96906	D-9	7
		D-6	14			D-9	12
MS21044N04	96906	D-3	28			D-13	4
MS21044N3	96906	D-3	62	MS90725-62	96906	D-7	2
		D-5	9			D-10	2
		D-7	29	MS90725-113	96906	D-12	8
MS21318-21	96906	D-7	22	MS90725-187	96906	D-12	3
MS25036-105	96906	D-6	23	MS90728-164	96906	D-1	2
MS25036-122	96906	D-2	4	M5086/1-6-9	81349	D-6	2
		D-5	6	M5086/1-16-9	81349	D-5	12
		D-6	3	M5086/1-18-9	81349	D-6	24
MS25036-151	96906	D-6	25	M5086/2-4-9	81349	D-5	4
MS25043-18DA	96906	D-3	25			D-6	13
MS27130-S100	96906	D-4	9	M5086/2-6-9	81349	D-5	7
MS27183-6	96906	D-3	53	QQ-W-343	81348	D-7	18
MS27183-8	96906	D-3	5	ZZ-H-428	81348	D-7	25
MS27183-10	97403	D-3	44	13205E4918	97403	D-7	20
		D-3	71	13206E4482-3	97403	D-1	3
		D-7	9	13211E3895-3	97403	D-4	3
MS27183-12	96906	D-9	4	13211E3895-5	97403	D-4	2
		D-10	8	13214E1213-1	97403	D-7	11
		D-11	4	13214E1214	97403	D-7	7
		D-13	5	13214E1223	97403	D-3	65
MS27183-13	96906	D-8	5			D-7	17
MS27183-14	96906	D-7	3	13214E1235	97403	D-7	5
		D-10	3	13214E1256	97403	D-8	1
MS27183-18	96906	D-12	9	13214E1259	97403	D-10	6
MS27183-21	96906	D-1	4	13214E1261	97403	D-10	5
MS27183-23	96906	D-12	4	13214E1263	97403	D-11	2
MS27183-42	96906	D-7	28	13214E1264	97403	D-11	1
MS3102R18-4P	96906	D-3	24	13214E1267-1	97403	D-9	8
		D-5	11	13214E1267-2	97403	D-9	10
MS35191-274	96906	D-7	27	13214E1268	97403	D-9	9
MS35206-217	96906	D-3	27	13214E1269	96906	D-13	7
MS35206-227	96906	D-3	51	13214E1270	97403	D-13	2
MS35206-246	96906	D-3	21	13214E1271	97403	D-13	1
MS35206-311	96906	D-7	6	13214E1272	97403	D-13	8
MS35207-265	96906	D-3	3	13214E1272	97403	D-12	2
		D-5	8	13214E1298	97403	D-12	6
MS35333-110	96906	D-3	69	13214E1299	97403	D-12	7
		D-7	16	13214E1300	97403	D-12	7
MS35338-41	96906	D-3	52	13214E1303	97403	D-12	1
MS35338-43	96906	D-3	4	13214E1309-1	97403	D-10	1
MS35335-93	96906	D-3	39	13214E1359	97403	D-3	33
MS35338-103	96906	D-3	64	13214E1360	97403	D-3	29
MS35425-28	96906	D-3	63	13214E1361	97403	D-3	31
		D-7	12	13214E1362	97403	D-3	30
MS35425-39	96906	D-3	46	13214E1363	97403	D-3	34
MS35489-27	96906	D-7	24	13214E1364	97403	D-3	23
MS35649-2252	96906	D-3	45	13214E1364	97403	D-3	57
MS35842-12	96906	D-7	23	13214E1391	97403	D-3	1
MS51007-6	96906	D-3	26	13214E1461	97403	D-9	1
MS51922-1	96906	D-3	72	13214E1462	97403	D-9	2
				13214E1463	97403	D-9	11
				13216E7579	97403	D-3	7
				13216E7604-37	97403	D-7	21

Section IV. NATIONAL STOCK NUMBER AND REFERENCE NUMBER INDEX - CONT

Reference Number	FSCM	Fig. No.	Item No.	Reference Number	FSCM	Fig. No.	Item No.
13217E15260-38	97403	D-4	8	13220E6421	97403	D-3	6
13217E2005	97403	D-3	32	13220E6422	97403	D-3	2
13218E5066-2	97403	D-3	38	13220E6423-1	97403	D-6	15
13218E5091	97403	D-7	26			D-6	16
13218E5119-6	97403	D-7	30	13220E6423-3	97403	D-6	17
13218E5136	97403	D-3	22	13220E6423-4	97403	D-6	18
13220E6400	97403	D-3	1	13220E6423-5	97403	D-6	19
13220E6401	97403	D-4	1	13220E6423-6	97403	D-6	20
13220E6402	97403	D-4	6	13220E6423-7	97403	D-6	21
13220E6403	97403	D-4	4	13220E6423-8	97403	D-6	22
13220E6404	97403	D-3	19	13220E6424	97403	D-6	1
13220E6405	97403	D-3	12	13220E6425	97403	D-3	37
13220E6406-1	97403	D-3	18	13220E6426	97403	D-5	10
13220E6406-2	97403	D-3	11	13220E6427	97403	D-2	1
13220E6407	97403	D-3	10	13220E6428	97403	D-3	55
13220E6408	97403	D-3	17	13220E6430	97403	D-3	9
13220E6409	97403	D-3	36	13220E6431	97403	D-3	13
13220E6410	97403	D-3	35	13220E6432-1	97403	D-3	50
13220E6415	97403	D-3	47	13220E6432-2	97403	D-3	56
13220E6416	97403	D-3	42	13220E6432-3	97403	D-3	54
13220E6417	97403	D-3	41	13220E6433	97403	D-3	15
13220E6418	97403	D-3	48	13220E6434	97403	D-3	16
13220E6419-1	97403	D-5	1	13220E6435	97403	D-3	14
13220E6419-2	97403	D-5	2	13220E6436	97403	D-3	43
13220E6420-1	97403	D-6	6	13220E8420-5	97403	D-6	10
13220E6420-2	97403	D-6	7	13227E0127-1	97403	D-6	12
13220E6420-3	97403	D-6	8	181-0937-003	72619	D-3	58
13220E6420-4	97403	D-6	9	181-8836-09-553	72619	D-3	60
13220E6420-6	97403	D-6	11				

Section V. REFERENCE DESIGNATOR INDEX

Not Applicable

By Order of the Secretary of the Army:

Official:

R. L. DILWORTH
Brigadier General, United States Army
The Adjutant General

CARL E. VUONO
General, United States Army
Chief of Staff

DISTRIBUTION:

To be distributed in accordance with DA 12-25A, Operator, Unit, Direct Support and General Support Maintenance Requirements for Generator Set, Diesel Engine Driven, Trailer Mounted (TM 5-6115-594 Series).

RECOMMENDED CHANGES TO EQUIPMENT TECHNICAL PUBLICATIONS



SOMETHING WRONG WITH THIS PUBLICATION?

THEN... JOT DOWN THE DOPE ABOUT IT ON THIS FORM, CAREFULLY TEAR IT OUT, FOLD IT AND DROP IT IN THE MAIL!

FROM: (PRINT YOUR UNIT'S COMPLETE ADDRESS)

PFC JOHN DOE
COA, 3d ENGINEER BN
FT. LEONARDWOOD, MD 63108

DATE SENT

PUBLICATION NUMBER

TM 5-6115-628-14&P

PUBLICATION DATE

PUBLICATION TITLE POWER PLANT

AN/MJQ-15 (NSN 6115-00-400-7591)

BE EXACT... PIN-POINT WHERE IT IS

PAGE NO.	PARA-GRAPH	FIGURE NO.	TABLE NO.
6	2-1 a		
B1		4-3	
125	line 20		

IN THIS SPACE TELL WHAT IS WRONG AND WHAT SHOULD BE DONE ABOUT IT:

In line 6 of paragraph 2-1a the manual states the engine has 6 cylinders. The engine on my set only has 4 cylinders. Change the manual to show 4 cylinders.

Callout 16 on figure 4-3 is pointing at a bolt. In key to figure 4-3, item 16 is called a shim - Please correct one or the other.

I ordered a gasket, item 19 on figure B-16 by NSN 2 910-00-762-3001. I got a gasket but it doesn't fit. Supply says I got what I ordered, so the NSN is wrong. Please give me a good NSN

PRINTED NAME, GRADE OR TITLE, AND TELEPHONE NUMBER

JOHN DOE, PFC (268) 317-7111

SIGN HERE:

JOHN DOE

DA FORM 2028-2
1 JUL 79

PREVIOUS EDITIONS ARE OBSOLETE.

DRSTS-M Overprint 1, 1 Nov 80

P.S.--IF YOUR OUTFIT WANTS TO KNOW ABOUT YOUR RECOMMENDATION MAKE A CARBON COPY OF THIS AND GIVE IT TO YOUR HEADQUARTERS.

TEAR ALONG PERFORATED LINE

FILL IN YOUR
UNIT'S ADDRESS



FOLD BACK

DEPARTMENT OF THE ARMY

OFFICIAL BUSINESS

TEAR ALONG PERFORATED LINE

RECOMMENDED CHANGES TO EQUIPMENT TECHNICAL PUBLICATIONS



SOMETHING WRONG WITH THIS PUBLICATION?

THEN... JOT DOWN THE DOPE ABOUT IT ON THIS FORM. CAREFULLY TEAR IT OUT. FOLD IT AND DROP IT IN THE MAIL!

FROM: (PRINT YOUR UNIT'S COMPLETE ADDRESS)

DATE SENT

PUBLICATION NUMBER

TM 5-6115-628-14&P

PUBLICATION DATE

PUBLICATION TITLE

POWER PLANT

AN/M10-15(NSN 6115-00-400-7591)

BE EXACT. . . PIN-POINT WHERE IT IS

PAGE NO	PARA-GRAPH	FIGURE NO	TABLE NO

IN THIS SPACE TELL WHAT IS WRONG AND WHAT SHOULD BE DONE ABOUT IT:

TEAR ALONG PERFORATED LINE

PRINTED NAME, GRADE OR TITLE, AND TELEPHONE NUMBER

SIGN HERE

DA FORM 2028-2
1 JUL 79

PREVIOUS EDITIONS ARE OBSOLETE.
DRSTS-M Overprint 2, 1 Nov 80.

P.S.--IF YOUR OUTFIT WANTS TO KNOW ABOUT YOUR RECOMMENDATION MAKE A CARBON COPY OF THIS AND GIVE IT TO YOUR HEADQUARTERS.

FILL IN YOUR
UNIT'S ADDRESS

FOLD BACK

DEPARTMENT OF THE ARMY

OFFICIAL BUSINESS

TEAR ALONG PERFORATED LINE

RECOMMENDED CHANGES TO EQUIPMENT TECHNICAL PUBLICATIONS



THEN... JOT DOWN THE DOPE ABOUT IT ON THIS FORM. CAREFULLY TEAR IT OUT. FOLD IT AND DROP IT IN THE MAIL!

SOMETHING WRONG WITH THIS PUBLICATION?

FROM: (PRINT YOUR UNIT'S COMPLETE ADDRESS)

DATE SENT

PUBLICATION NUMBER

TM 5-6115-628-14&P

PUBLICATION DATE

PUBLICATION TITLE

POWER PLANT
AN/MJO-15 (NSN 6115-00-400-7591)

BE EXACT . . . PIN-POINT WHERE IT IS

PAGE NO	PARA-GRAPH	FIGURE NO	TABLE NO

IN THIS SPACE TELL WHAT IS WRONG AND WHAT SHOULD BE DONE ABOUT IT:

PRINTED NAME, GRADE OR TITLE, AND TELEPHONE NUMBER

SIGN HERE

DA FORM 2028-2
1 JUL 79

PREVIOUS EDITIONS ARE OBSOLETE.
DRSTS-M Overprint 2, 1 Nov 80.

P.S.--IF YOUR OUTFIT WANTS TO KNOW ABOUT YOUR RECOMMENDATION MAKE A CARBON COPY OF THIS AND GIVE IT TO YOUR HEADQUARTERS.

TEAR ALONG PERFORATED LINE

FILL IN YOUR
UNIT'S ADDRESS



FOLD BACK

DEPARTMENT OF THE ARMY

OFFICIAL BUSINESS

TEAR ALONG PERFORATED LINE

RECOMMENDED CHANGES TO EQUIPMENT TECHNICAL PUBLICATIONS



THEN . . . JOT DOWN THE DOPE ABOUT IT ON THIS FORM. CAREFULLY TEAR IT OUT. FOLD IT AND DROP IT IN THE MAIL!

SOMETHING WRONG WITH THIS PUBLICATION?

FROM: (PRINT YOUR UNIT'S COMPLETE ADDRESS)

DATE SENT

PUBLICATION NUMBER

TM 5-6115-628-14&P

PUBLICATION DATE

PUBLICATION TITLE

POWER PLANT
AN/MJO-15 (NSN 6115-00-400-7591)

BE EXACT . . . PIN-POINT WHERE IT IS

PAGE NO	PARA-GRAPH	FIGURE NO	TABLE NO

IN THIS SPACE TELL WHAT IS WRONG AND WHAT SHOULD BE DONE ABOUT IT:

PRINTED NAME, GRADE OR TITLE, AND TELEPHONE NUMBER

SIGN HERE

TEAR ALONG PERFORATED LINE

DA FORM 2028-2
1 JUL 79

PREVIOUS EDITIONS ARE OBSOLETE.
DRSTS-M Overprint 2, 1 Nov 80.

P.S.--IF YOUR OUTFIT WANTS TO KNOW ABOUT YOUR RECOMMENDATION MAKE A CARBON COPY OF THIS AND GIVE IT TO YOUR HEADQUARTERS.

FILL IN YOUR
UNIT'S ADDRESS



FOLD BACK

DEPARTMENT OF THE ARMY

OFFICIAL BUSINESS

TEAR ALONG PERFORATED LINE

The Metric System and Equivalents

Linear Measure

1 centimeter = 10 millimeters = .39 inch
 1 decimeter = 10 centimeters = 3.94 inches
 1 meter = 10 decimeters = 39.37 inches
 1 dekameter = 10 meters = 32.8 feet
 1 hectometer = 10 dekameters = 328.08 feet
 1 kilometer = 10 hectometers = 3,280.8 feet

Weights

1 centigram = 10 milligrams = .15 grain
 1 decigram = 10 centigrams = 1.54 grains
 1 gram = 10 decigram = .035 ounce
 1 dekagram = 10 grams = .35 ounce
 1 hectogram = 10 dekagrams = 3.52 ounces
 1 kilogram = 10 hectograms = 2.2 pounds
 1 quintal = 100 kilograms = 220.46 pounds
 1 metric ton = 10 quintals = 1.1 short tons

Liquid Measure

1 centiliter = 10 milliliters = .34 fl. ounce
 1 deciliter = 10 centiliters = 3.38 fl. ounces
 1 liter = 10 deciliters = 33.81 fl. ounces
 1 dekaliter = 10 liters = 2.64 gallons
 1 hectoliter = 10 dekaliters = 26.42 gallons
 1 kiloliter = 10 hectoliters = 264.18 gallons

Square Measure

1 sq. centimeter = 100 sq. millimeters = .155 sq. inch
 1 sq. decimeter = 100 sq. centimeters = 15.5 sq. inches
 1 sq. meter (centare) = 100 sq. decimeters = 10.76 sq. feet
 1 sq. dekameter (are) = 100 sq. meters = 1,076.4 sq. feet
 1 sq. hectometer (hectare) = 100 sq. dekameters = 2.47 acres
 1 sq. kilometer = 100 sq. hectometers = .386 sq. mile

Cubic Measure

1 cu. centimeter = 1000 cu. millimeters = .06 cu. inch
 1 cu. decimeter = 1000 cu. centimeters = 61.02 cu. inches
 1 cu. meter = 1000 cu. decimeters = 35.31 cu. feet

Approximate Conversion Factors

To change	To	Multiply by	To change	To	Multiply by
inches	centimeters	2.540	ounce-inches	newton-meters	.007062
feet	meters	.305	centimeters	inches	.394
yards	meters	.914	meters	feet	3.280
miles	kilometers	1.609	meters	yards	1.094
square inches	square centimeters	6.451	kilometers	miles	.621
square feet	square meters	.093	square centimeters	square inches	.155
square yards	square meters	.836	square meters	square feet	10.764
square miles	square kilometers	2.590	square meters	square yards	1.196
acres	square hectometers	.405	square kilometers	square miles	.386
cubic feet	cubic meters	.028	square hectometers	acres	2.471
cubic yards	cubic meters	.765	cubic meters	cubic feet	35.315
fluid ounces	milliliters	29.573	cubic meters	cubic yards	1.308
pints	liters	.473	milliliters	fluid ounces	.034
quarts	liters	.946	liters	pints	2.113
gallons	liters	3.785	liters	quarts	1.057
ounces	grams	28.349	liters	gallons	.264
pounds	kilograms	.454	grams	ounces	.035
short tons	metric tons	.907	kilograms	pounds	2.205
pound-feet	newton-meters	1.356	metric tons	short tons	1.102
pound-inches	newton-meters	.11296			

Temperature (Exact)

°F	Fahrenheit temperature	5/9 (after subtracting 32)	Celsius temperature	°C
----	------------------------	----------------------------	---------------------	----

The Metric System and Equivalents

Linear Measure

1 centimeter = 10 millimeters = .39 inch
 1 decimeter = 10 centimeters = 3.94 inches
 1 meter = 10 decimeters = 39.37 inches
 1 dekameter = 10 meters = 32.8 feet
 1 hectometer = 10 dekameters = 328.08 feet
 1 kilometer = 10 hectometers = 3,280.8 feet

Weights

1 centigram = 10 milligrams = .15 grain
 1 decigram = 10 centigrams = 1.54 grains
 1 gram = 10 decigram = .035 ounce
 1 dekagram = 10 grams = .35 ounce
 1 hectogram = 10 dekagrams = 3.52 ounces
 1 kilogram = 10 hectograms = 2.2 pounds
 1 quintal = 100 kilograms = 220.46 pounds
 1 metric ton = 10 quintals = 1.1 short tons

Liquid Measure

1 centiliter = 10 milliliters = .34 fl. ounce
 1 deciliter = 10 centiliters = 3.38 fl. ounces
 1 liter = 10 deciliters = 33.81 fl. ounces
 1 dekaliter = 10 liters = 2.64 gallons
 1 hectoliter = 10 dekaliters = 26.42 gallons
 1 kiloliter = 10 hectoliters = 264.18 gallons

Square Measure

1 sq. centimeter = 100 sq. millimeters = .155 sq. inch
 1 sq. decimeter = 100 sq. centimeters = 15.5 sq. inches
 1 sq. meter (centare) = 100 sq. decimeters = 10.76 sq. feet
 1 sq. dekameter (are) = 100 sq. meters = 1,076.4 sq. feet
 1 sq. hectometer (hectare) = 100 sq. dekameters = 2.47 acres
 1 sq. kilometer = 100 sq. hectometers = .386 sq. mile

Cubic Measure

1 cu. centimeter = 1000 cu. millimeters = .06 cu. inch
 1 cu. decimeter = 1000 cu. centimeters = 61.02 cu. inches
 1 cu. meter = 1000 cu. decimeters = 35.31 cu. feet

Approximate Conversion Factors

To change	To	Multiply by	To change	To	Multiply by
inches	centimeters	2.540	ounce-inches	newton-meters	.007062
feet	meters	.305	centimeters	inches	.394
yards	meters	.914	meters	feet	3.280
miles	kilometers	1.609	meters	yards	1.094
square inches	square centimeters	6.451	kilometers	miles	.621
square feet	square meters	.093	square centimeters	square inches	.155
square yards	square meters	.836	square meters	square feet	10.764
square miles	square kilometers	2.590	square meters	square yards	1.196
acres	square hectometers	.405	square kilometers	square miles	.386
cubic feet	cubic meters	.028	square hectometers	acres	2.471
cubic yards	cubic meters	.765	cubic meters	cubic feet	35.315
fluid ounces	milliliters	29.573	cubic meters	cubic yards	1.308
pints	liters	.473	milliliters	fluid ounces	.034
quarts	liters	.946	liters	pints	2.113
gallons	liters	3.785	liters	quarts	1.057
ounces	grams	28.349	liters	gallons	.264
pounds	kilograms	.454	grams	ounces	.035
short tons	metric tons	.907	kilograms	pounds	2.205
pound-feet	newton-meters	1.356	metric tons	short tons	1.102
pound-inches	newton-meters	.11296			

Temperature (Exact)

°F	Fahrenheit temperature	5/9 (after subtracting 32)	Celsius temperature	°C
----	------------------------	----------------------------	---------------------	----

