

THE MONARCH
MACHINE TOOL COMPANY

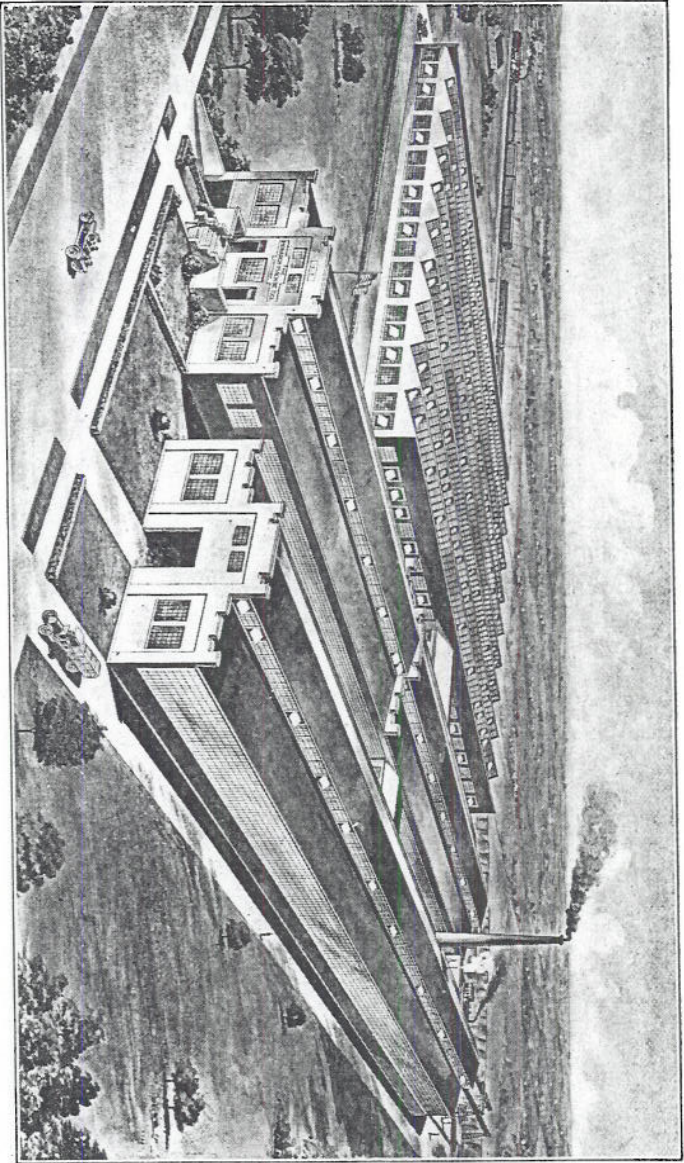

SIDNEY, OHIO.



The Home of Monarch Lathes

This modern plant is devoted to the exclusive manufacture of engine lathes of from 10 to 30 inch swing.

OUR GUARANTEE

Your MONARCH lathe must give complete satisfaction. If it does not, write the dealer who sold you the lathe, giving full details, and send us a copy of your letter. Our interest in your lathe does not cease when it leaves our factory, and we want every user to feel that we are just as interested in the production and accurate work of his MONARCH lathe as he is.

Our Service Department is always at your disposal, and we can assure you it will be a real pleasure to assist you in any difficulties that may arise. Our wide experience, developed by devoting our entire energies to the manufacture of engine lathes, enables us to give you the best of service, and satisfaction.

All materials and workmanship entering into MONARCH lathes are guaranteed to be perfect, and we will replace any part free of charge, if it proves defective. All so claimed defective parts must be returned to us for our inspection.

UNPACKING

This lathe should be carefully uncrated, so the finished parts and general appearance of the lathe will not be marred. All the accessories on the machine as well as those in the box attached to crate should be checked with the packing list. Any shortage of parts should be promptly reported.

Wash off the anti-rust slush with kerosene or naphtha, as this interferes with the easy operation of the tool. Remove the back gear and face gear guards, and wash the slush from these gears, as the slush gets thick and causes the gears to run hard. Also run the tailstock spindle out about six inches and remove the slush.

Be sure no dirt remains or gets into the oil holes or tubes. This can be removed with gasoline.

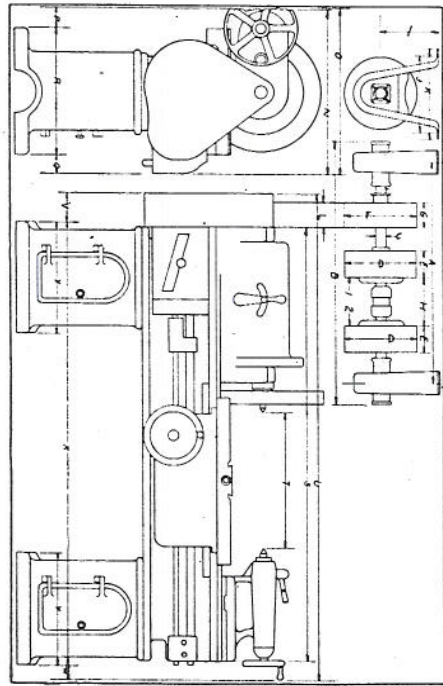
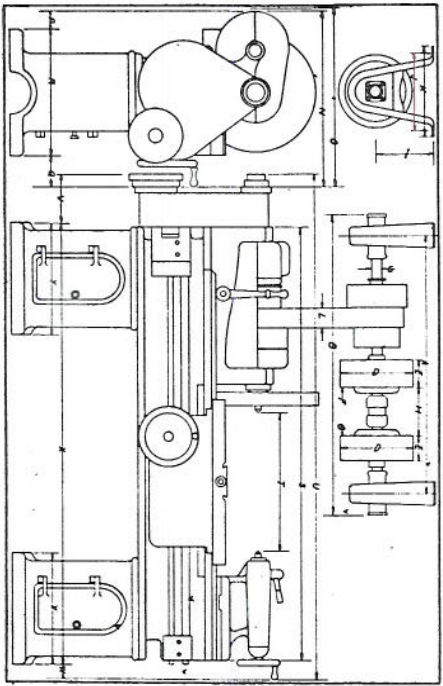

14" and 16" Lathe 6' Bed	F-18" H-49 1/2" G-14"
18" and 20" Lathe 8' Bed	F-17 1/2" H-63 1/2" G-14 1/4"
24, 26, 28, 30" Lathe 10' Bed	F-19 3/4" H-70 1/4" G-22 1/4"

10" and 12" Lathe 6' Bed	B-18 1/2" A-63 1/2"
14" and 16" Lathe 6' Bed	B-19 1/2" A-60"
18" and 20" Lathe 8' Bed	B-20 3/4" A-91 1/4"

14" and 16" Lathe 6' Bed	C-18" D-14"	B-19 1/4" E-48 3/4"
18" and 20" Lathe 8' Bed	C-17 1/2" D-14 1/4"	B-20 3/4" E-76 1/2"

	10"	12"	14"	16"	H. D.	17"	18"	20"	24"	26"	28"	30"
A	Center to Center of Hanger.....	32"	32"	32"	32"	41"	41"	41"	51"	51"	51"	51"
B	Extreme length of Shaft.....	37"	37"	37"	37"	49"	49"	49"	59"	59"	59"	59"
C	Diameter of Shaft.....	1 3/8"	1 3/8"	1 3/8"	1 3/8"	1 3/8"	1 3/8"	1 3/8"	1 3/8"	1 3/8"	1 3/8"	1 3/8"
D	Diameter of Chutch Pulley.....	8"	8"	10"	10"	12"	12"	12"	18"	18"	18"	18"
E	Width of Face.....	2 5/8"	2 5/8"	3 1/2"	3 1/2"	4 1/2"	4 1/2"	4 1/2"	6 3/8"	6 3/8"	6 3/8"	6 3/8"
F	Revolutions per Minute.....	250	250	200	200	190	190	190	150	150	150	150
G	Distance between Centers.....	7 1/2"	7 1/2"	8 3/4"	8 3/4"	8"	8"	8"	13 1/2"	13 1/2"	13 1/2"	13 1/2"
H	Drop of Hangers.....	9"	9"	9"	9"	12 1/2"	12 1/2"	12 1/2"	11 1/2"	11 1/2"	11 1/2"	11 1/2"
I	Center to Center of Bolt Holes.....	11"	11"	11"	11"	14 3/4"	14 3/4"	14 3/4"	15 3/4"	15 3/4"	15 3/4"	15 3/4"
J	Width of Hangers.....	22"	22"	28 1/2"	28 1/2"	29 1/2"	29 1/2"	29 1/2"	49"	49"	49"	49"
K	Width of Plain Lathe over all.....	22"	22"	29 1/2"	29 1/2"	38 1/2"	38 1/2"	38 1/2"	64"	64"	64"	64"
L	Width of Taper Attachment Lathe over all.....	29 1/2"	29 1/2"	32 1/2"	32 1/2"	38 1/2"	38 1/2"	38 1/2"	64"	64"	64"	64"
M	Back overhang.....	2"	2"	4 3/4"	4 3/4"	7"	7"	7"	15 1/2"	15 1/2"	15 1/2"	15 1/2"
N	Front Side Overhang.....	5"	5"	6"	6"	8"	8"	8"	10"	10"	10"	10"
O	Length of Bed figures are based on.....	68"	68"	86"	86"	111"	111"	111"	132"	132"	132"	132"
P	Length over all.....	70"	70"	100"	100"	121"	121"	121"	154"	154"	154"	154"
Q	Rear End overhang.....	4 1/2"	4 1/2"	5"	5"	6"	6"	6"	7 1/2"	7 1/2"	7 1/2"	7 1/2"
R	Length over Legs (1 Cabinet and 1 Skeleton).....	55"	55"	65"	65"	80"	80"	80"	100"	100"	100"	100"
S	Length over Legs (Two Cabinet).....	22"	22"	23"	23"	23"	23"	23"	28"	28"	28"	28"
T	Length of Leg (Cabinet).....	22"	22"	23"	23"	21"	21"	21"	28"	28"	28"	28"
U	Length of Leg (Skeleton).....	22"	22"	23"	23"	21"	21"	21"	28"	28"	28"	28"
V	Width of Leg (Cabinet).....	22"	22"	23"	23"	21"	21"	21"	28"	28"	28"	28"
W	Width of Leg (Skeleton).....	22"	22"	23"	23"	21"	21"	21"	28"	28"	28"	28"
X	Length over Legs (1 Cabinet).....	55"	55"	65"	65"	80"	80"	80"	100"	100"	100"	100"
Y	Length over Legs (2 Cabinet).....	55"	55"	65"	65"	80"	80"	80"	100"	100"	100"	100"
Z	Width of Cabinet Leg.....	67"	67"	67"	67"	96"	96"	96"	123"	123"	123"	123"
X	Length over Legs (2 Cabinet).....	67"	67"	67"	67"	96"	96"	96"	123"	123"	123"	123"

	10"	12"	14"	16"	H. D.	17"	18"	20"	24"	26"	28"	30"
I	R. P. N. of Driving Pulley.....	325	325	300	300	275	275	275	250	250	250	250
L	Width of Drive Pulley.....	2 5/8"	2 5/8"	3 1/2"	3 1/2"	4 1/2"	4 1/2"	4 1/2"	6 3/8"	6 3/8"	6 3/8"	6 3/8"
M	Diameter of Head Driving Pulley.....	8"	8"	10"	10"	14"	14"	14"	18"	18"	18"	18"
N	Width of Plain Lathe over all.....	20 1/2"	20 1/2"	29 1/2"	29 1/2"	38"	38"	38"	39 3/4"	39 3/4"	39 3/4"	39 3/4"
O	Width of Taper Attachment Lathe over all.....	24 1/2"	24 1/2"	30"	30"	38 1/2"	38 1/2"	38 1/2"	47 1/2"	47 1/2"	47 1/2"	47 1/2"
P	Back overhang.....	2"	2"	6"	6"	7"	7"	7"	10 3/4"	10 3/4"	10 3/4"	10 3/4"
Q	Front Side overhang.....	1"	1"	3 1/2"	3 1/2"	6"	6"	6"	7 1/2"	7 1/2"	7 1/2"	7 1/2"
R	Length of Bed figures are based on.....	22"	22"	23"	23"	25"	25"	25"	10"	10"	10"	10"
S	Distance between Centers T. S. Flush.....	5"	5"	6"	6"	8"	8"	8"	56"	56"	56"	56"
T	Length over all.....	28"	28"	33"	33"	38"	38"	38"	11"	11"	11"	11"
U	Front End overhang.....	67"	67"	86"	86"	116"	116"	116"	140"	140"	140"	140"
V	Length over Legs (1 Cabinet).....	4 1/2"	4 1/2"	10"	10"	15"	15"	15"	5 1/2"	5 1/2"	5 1/2"	5 1/2"
W	Length over Legs (2 Cabinet).....	7 1/2"	7 1/2"	10"	10"	15"	15"	15"	5 1/2"	5 1/2"	5 1/2"	5 1/2"
X	Width of Cabinet Leg.....	55"	55"	65"	65"	80"	80"	80"	100"	100"	100"	100"
Y	Length over Legs (1 Cabinet).....	64 1/2"	64 1/2"	64 1/2"	64 1/2"	95 1/2"	95 1/2"	95 1/2"	118 1/2"	118 1/2"	118 1/2"	118 1/2"
Z	Width of Cabinet Leg.....	17"	17"	17"	17"	18"	18"	18"	23"	23"	23"	23"
X	Length over Legs (2 Cabinet).....	21"	21"	21"	21"	21"	21"	21"	28"	28"	28"	28"
X	Length over Legs (2 Cabinet).....	67"	67"	67"	67"	96"	96"	96"	123"	123"	123"	123"

MONARCH LATHES

INSTALLATION

Proper installation of any machine tool is the biggest factor in its successful operation. To be properly installed it must be absolutely level. It can easily be seen that if the lathe is not level or is installed on a twist, the bearings are changed, which is the most important part in the workmanship. This will cause chatter, concave and convex cuts, taper longitudinal work and in fact, nearly all the complaints can be traced to improper leveling.

We strongly recommend and urge our customers to use a good, long machinist's level with graduated vial, such as shown in the illustration. The lathe should be leveled at both the head and tail

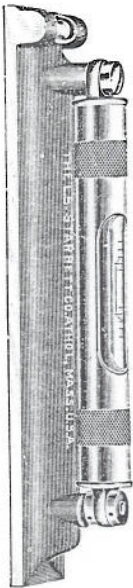

To maintain this level after lagging to the floor, a good, solid foundation is necessary. The lathe should not be subject to the vibration of the floor or any other cause. The best foundation is none too good for any machine tool.

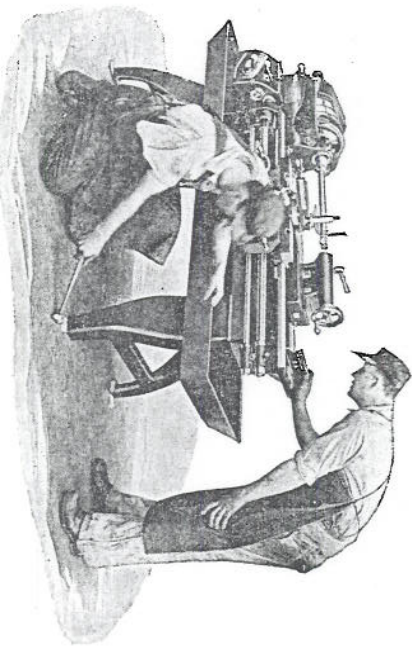

end, across the vee's, both before and after lagging to the floor. Do not use a carpenter's level, as it is not accurate enough. Time consumed in leveling your lathe is well spent, and as a result, the accuracy and efficiency built in your lathe will be brought into use. After the lathe has been first set up, it will not keep its original level, but will fit itself to the floor. It is very important, therefore, that the machine be leveled at least once a week for the following six or eight weeks after installation.

The matter of proper installation is one of great importance, and we are very much interested to see every one of our lathes in a perfectly level condition, on a good, solid foundation. Our wide experience has taught us that this is absolutely necessary, and we wish every user to profit by this advice.

LUBRICATION

Every person who is familiar with machinery knows it must be well oiled, with a grade of oil suitable for the purpose. It is very important that every bearing in the machine receives its proper amount of lubrication, and a sufficient number of holes and tubes are provided for this purpose.

All these oil holes and tubes are in full view of the operator,

OPERATION

While MONARCH lathes are noted for their simplicity, a few pages will be devoted to the inexperienced, who should also read the foregoing pages carefully.

The Headstock. Nearly all of our lathes are now built with a three-step cone, and double back gears of the positive, sliding type. With this construction it is possible to obtain a large variety of spindle speeds, in the shortest time.

The face gear, or the large gear near the front bearing is keyed to the spindle, but the drive cone pulley runs free. In the face of the drive cone is a hole for receiving the locking pin of the face gear. When the lathe is running in "Open Belt" the power is not transmitted direct from the cone pulley to the spindle, but through the face gear, by means of the locking pin. This arrangement is necessary, due to the operation of the back gears. If the locking pin is pulled from the cone pulley, it will run free on the spindle.

Slip the back gears on the quill to the right, and bring them forward by means of the handle fastened to the eccentric shaft. This must be done while the lathe is **not** in motion. The spindle speed is now about two-fifths as fast as in open belt, depending upon the ratio of the first back gearing. If the gears which slide on the quill are shifted to the left and engaged, the spindle speed is about

and should be gone over frequently. The oil tubes in the drive cone and also in the back gear quill should be given a liberal supply, as this is the means of filling the reservoir for the constant supply of oil to these parts.

We believe every user of Machine Tools knows the necessity of proper lubrication, and will attend to this matter properly.

one-eighth of the open belt. Any variation of the above speeds, is obtained by shifting the belt to the different steps on the cone pulley. If a wider range of speeds is desired, pulleys of different diameter can be used to drive the double friction countershaft.

By means of the back gear eccentric shaft, a close adjustment of the back gears can be obtained. See that these gears are always properly adjusted to run noiselessly.

Feed Parts. Power for the feed is obtained direct from the spindle, so the feed ratio is the same when the lathe is in back gear or open belt. Directly under the spindle feed gear is the reverse gear bracket, for reversing the revolutions of the lead screw only. This can be done while the lathe is in motion.

For fine feeds, the large quadrant gear should mesh with forty-eight tooth gear box drive gear and for very coarse or roughing feeds, with the twenty-four tooth gear box drive gear. The above is the case with the 14" lathes and larger sizes, but on our 10" and 12" lathe this result is produced by replacing the sixty-four tooth gear box drive gear with the thirty-two tooth stud gear. Any variation of the above extremes is controlled by the gear box levers, providing a wide range of feed for all purposes.

The feed on our 10" and 12" lathes, is twice the thread while on our lathes from 14" to 30" it is four times the thread.

Loose Change Gear Lathes. Feed for these lathes is provided by a belt, driven from a three-step cone pulley, giving three changes of feed of wide variation. If this feed is inadequate the feed rod can be geared from the lead screw by moving the sliding gear on the feed rod. The result is a coarser and positive feed, and can be varied by using different change gears.

The Apron. The apron receives its power from a sliding double bevel pinion, keyed to the feed rod, and meshing with a larger bevel gear. The shifting of these bevel pinions, by the lever in the lower right corner of the apron, provides the feed reverse and also disengages the feed. This lever should be used to control all feeds, both cross and longitudinal.

The cross feed is engaged by turning the smaller star handwheel to the left, and the longitudinal feed is engaged by turning the large star handwheel to the right. The feeds are disengaged by reversing the above operation, and the direction of both feeds are changed by the reverse lever.

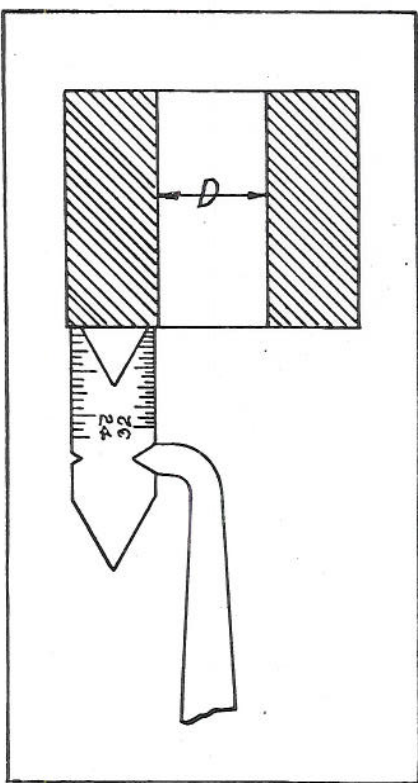
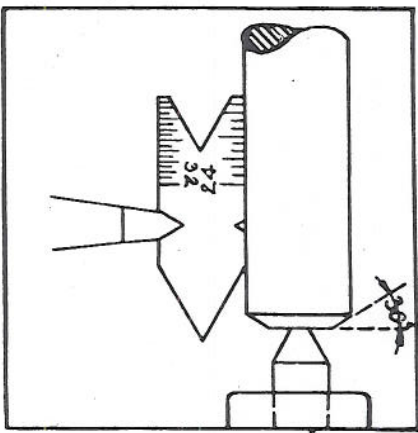

Thread Cutting. Threads are cut in a lathe by advancing the carriage in some ratio with the revolutions of the spindle. The carriage is always moved by closing the half nuts on the lead screw, which is geared direct from the spindle.

The periphery speed of the work to be threaded should be considerably less than in plain turning, especially on accurate work. In roughing the thread, it is best to do most of the feeding of the thread tool with the compound set at an angle of thirty degrees. This will cause most of the cutting to be done on one side, which keeps the tool from jamming, and also allows quicker work to be done. Of course, in finishing the thread, only the cross feed can be used.

When beginning to chase threads, see that the large quadrant gear is in mesh with the proper gear on the gear box, and the gear box levers are in their proper position. Move the sliding gear on the lead screw to the right as far as possible.

Put the apron reverse lever in central position. Swing the compound rest swivel to an angle of thirty degrees.

Be sure the chuck or dog is tight on the shaft or arbor and also lubricant placed on the tailstock center where it enters the shaft or arbor.

The threading tool should be ground to an angle of sixty degrees if a V or U. S. Standard thread is to be cut, using a center gauge. This gauge is also used for squaring the tool with the axis of the lathe. (See illustrations.)

Care should be taken in setting the threading tool and also in grinding, as all rules and formulas are made with the understanding that the outline of the thread is perfect.

The depth of the cut depends much upon the material used, so the operator must be the judge. A little experience will soon teach the beginner.

Never loosen the dog or chuck from the work until the thread is finished, and when taking a piece off centers to try for size, be sure to put tail of the dog in the same slot in the dog or face plate from which it was taken. If the operator fails to do this, a split thread may be the result.

If the tool must be removed for grinding, care should be taken in beginning the next cut. The tool should be placed about $\frac{1}{8}$ " from the outside diameter of the thread, and the half-nuts engaged while the machine is in motion. In order to have the tool engage the thread exactly, it will have to be adjusted by means of the compound rest set at an angle of thirty degrees, and the cross feed.

In finishing the thread, a case hardened nut is generally used to determine the size. If this method is not practical, a pair of thread calipers or a thread micrometer can be used. The following are the formulas:

Sharp V Thread

$$P\text{---pitch} = \frac{1}{\text{No. threads per in.}}$$

$$D\text{---depth} = \text{pitch} \times .8660$$

U. S. Standard Thread

$$P\text{---pitch} = \frac{1}{\text{No. threads per inch}}$$

$$D\text{---depth} = P \times .6495$$

$$F\text{---flat} = \frac{P}{8}$$

The F or flat referred to above is the flat space at the top and bottom of all United States Standard Threads.

The depth of Square Threads or 29 degrees Screw Thread (Acme Standard) is equal to $\frac{1}{\text{No. of threads per inch} \times 2}$ plus .010".

It is best to grind the tool for 29 degree Screw Threads (Acme Standard) to a gauge made for that purpose. The correct angle and also the width at the bottom of the thread, are then easily obtained.

The width of the tool for square threads equals $\frac{1}{\text{No. of threads per inch} \times 2}$ plus .001.

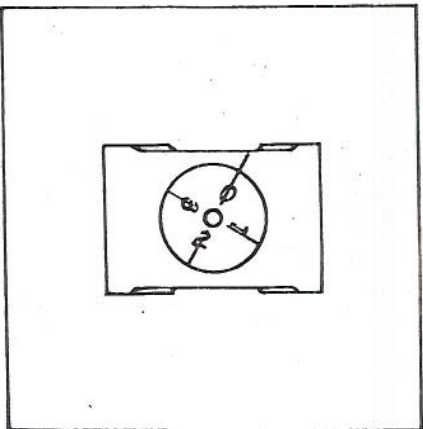

Thread Chasing Dial. When the number of threads per inch of the lead screw can be evenly divided into the number of threads to be cut, no chasing dial is needed and the half nut can be closed at any time. However, when the number of threads per inch cannot be so divided, the chasing dial proves its usefulness.

The chasing dials used on our quick change gear lathes are divided into four divisions as shown in the illustration.

For all even and odd threads, engage the half nuts at any line. When cutting threads of a pitch involving one-half of a thread in each inch, close the half nuts at any half revolution. When chasing threads of a pitch involving one-quarter of a thread, to each inch, engage the half nuts at any full revolution.

The use of this chasing dial eliminates the necessity of reversing the headstock spindle or marking the starting point on the bed.

Taper Turning. The best way to turn or bore any taper is with the taper attachment. In this way the centers are kept in line, the job is easier to set up and better work can be done.

To use the taper attachment, release the cross feed nut by taking out the cap screw, and bring to the front by means of the cross feed screw. Connect the bar with the cross slide with the same

screw that held the cross feed nut. Swing the swivel in either direction, depending on the taper, which can be determined by the graduations on the end. Tighten the swivel with the cap screws at either end. After the work has been placed between centers or in the chuck, the cutting tool should be placed close to the work, and the far end of the connecting bar tightened to the slide that works on the swivel. All the cross feeding will now have to be done with the compound rest. Clamp the dog of the taper attachment to the bed and it is ready for use. Some assistance may be had by referring to Figure 502.

It is sometimes necessary to turn a taper that is greater than the range of the attachment. This can be done by swinging the swivel as far as possible and taking up the balance of the taper by setting over the tailstock.

When turning or boring a taper the cutting tool should be exactly on center.

DON'T'S FOR MACHINISTS

From "Machinery"

- Don't run a lathe with the belt too tight.
- Don't run the point of your lathe tool into the mandrel or arbor.
- Don't rap the chips out of your file on the lathe shears.
- Don't set a lathe tool below the center for external work.
- Don't start a lathe without seeing that the tailstock spindle is locked.
- Don't put an arbor or shaft on the lathe centers without lubricant on them.
- Don't leave too much stock on a piece of work to take off with the finishing cut.
- Don't try a steel gauge or an expensive caliper on a shaft while it is running.
- Don't put a mandrel into a newly bored hole without a lubricant of some kind on.
- Don't put a piece of work on centers unless you know the internal centers are clean.
- Don't try to straighten a shaft on lathe center, and expect that the centers will run true afterwards.
- Don't put a piece of work on the centers unless you know all your centers are at the same angles.
- Don't take a lathe center out of its socket without having a witness mark on it, and put it back again according to the mark.
- Don't start polishing on the lathe centers without having it loose enough to allow for the expansion by heat from the polishing process.
- Don't run your lathe tool into the face plate.
- Don't try to knurl a piece of work without oiling it.
- Don't run a lathe an instant after the center begins to squeal.
- Don't forget to oil your machine every morning; it works better.
- Don't forget that a fairly good center punch may be made from a piece of round file.
- Don't forget that a surface, polished with oil will keep clean much longer than one polished dry.
- Don't start to turn a job up on lathe centers unless you know that the centers are both in line with the ways.
- Don't cross the belt laces on the side next to the pulley, for that makes them cut themselves in two.
- Don't try to cut threads on steel or wrought iron dry; use lard oil or a cutting compound.
- Don't run a chuck or face plate up to the shoulder suddenly; it strains the spindle and the threads and makes removal difficult.
- Don't screw a tool post screw any tighter than is absolutely necessary; many mechanics have a false idea as to how tight a tool should be to do its work.
- To drive a center out of the head spindle use a rod and drive through the hole in the spindle.
- When putting a lathe chuck on the head spindle always remove the center.
- When the center is removed from the head spindle of the lathe, always put a rag in the spindle to prevent any dirt from collecting.

Taper Attachment

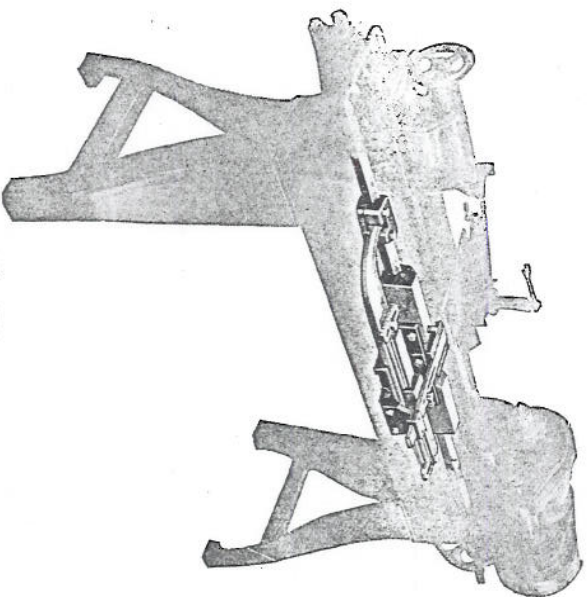
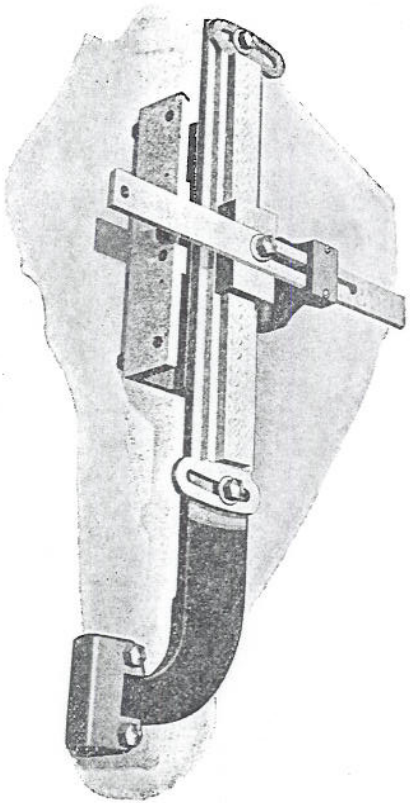

Fig. 502

Taper attachments can be attached to any MONARCH lathe any time after the lathe has left the factory, as all carriages are drilled and tapped to fit same.

The swivel is graduated in both degrees and inches and turns all tapers up to three inches per foot.

We invite correspondence in regard to special forming attachments.

Draw-In Attachment

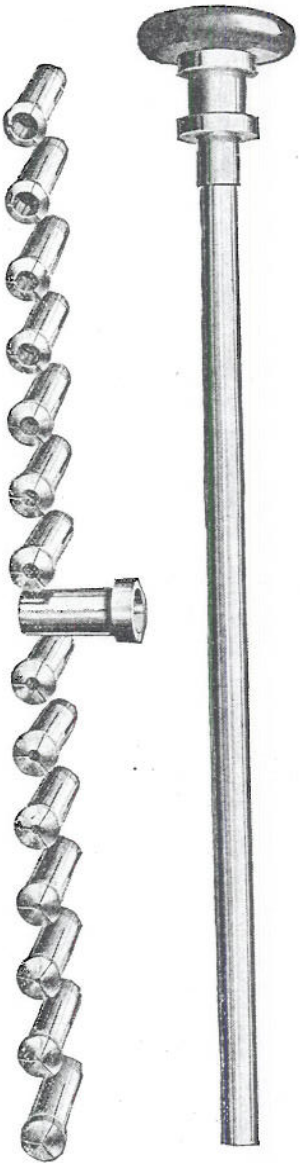

A very useful attachment for the tool room and also for light manufacturing. The collets for use in connection with the attachment can be made for round, square or hexagonal stock, and are made from tool steel, hardened and ground.

A complete assortment of these collets is carried in stock. Any size collet, within capacity, can be furnished immediately.

The maximum capacity of the collets for our 10" and 12" lathes is $\frac{5}{8}$ ", 14" and 16" is $\frac{1}{2}$ ", 18" and 20" is $1\frac{1}{8}$ ", and the 24" to 30" is $1\frac{3}{8}$ ". Complete attachment consists of bar with handle, sleeve and 4 collets.

Step Chuck and Closer

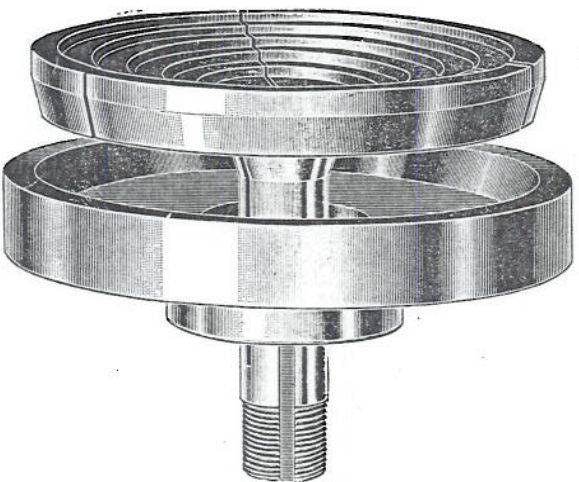

Fig. 3

These accessories are extremely useful in holding large and small punchings, thin tubing, etc., the chucks being readily turned out for receiving the work to be held.

The closers are carried on the nose of the spindle, and are all interchangeable with the taper on it. The mouth of the closer is finished with taper coincident with that of the outer periphery of the step chuck, and grip is given to the work through pull of draw-in bar.

Hyatt Roller Bearing Countershaft

Efficiency. The rolling motion of the Hyatt bearing instead of the dragging friction of a plain bearing means the transmission of more power to the machine. Wear is eliminated and the bearing cannot heat up. These bearings are capable of carrying the maximum load that can be put on the shaft.

Economy. The oil tight housing and the hollow rollers hold sufficient oil for a long period of time. The helical slots continually carry oil alternately back and forth over the bearing surfaces. Generally Hyatt countershafts are oiled three or four times a year.

These can be furnished at slight additional cost.

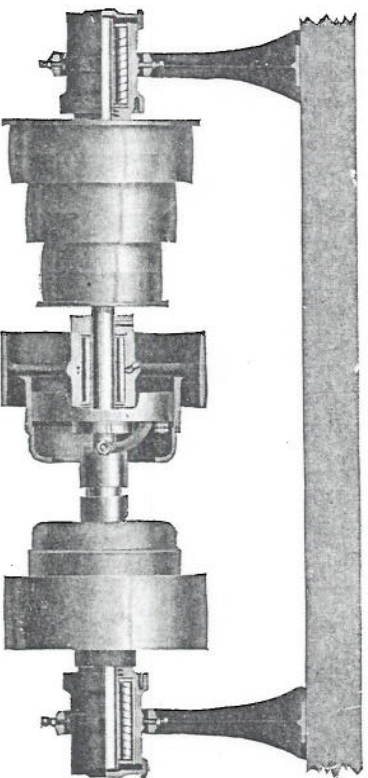

Fig. 4—Sectional View Hyatt Equipped Countershaft

Combined Milling and Gear Cutting Attachment

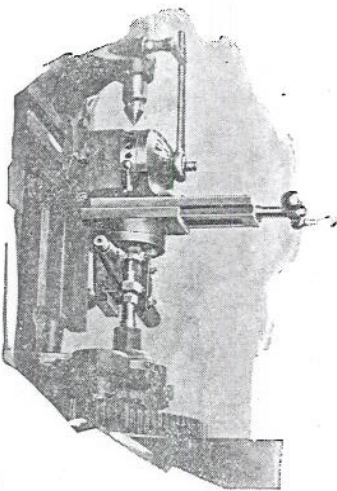

Fig. 500

Cutting key seat in auto shaft, using angle plate in place of index head.

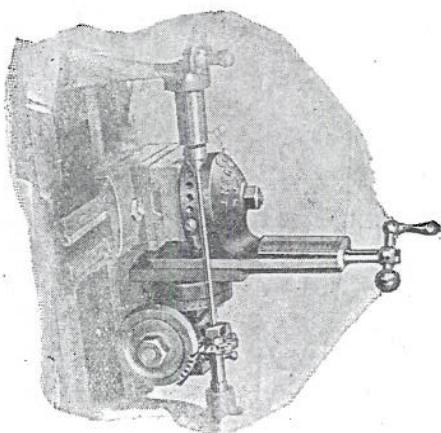

Fig. 501

Attachment holding blank and spacing teeth, in gear cutting. Cutter carried on mandrel between lathe centers.

IT IS EASILY AND QUICKLY ADJUSTED

The attachment is bolted to the tool-post slot on the cross-slide of the lathe with one T-bolt and nut and it is ready for service. This can be done by the machinist in 4 or 5 minutes. The lathe carries the cutting tool, furnishes the power, and produces the cross and longitudinal feeds. The attachment is adjustable to hold the

work in any desired position and at any desired angle with the cutting direction of the tool, and to space the work by turning it through any desired part of a revolution. The attachment also produces a vertical feed.

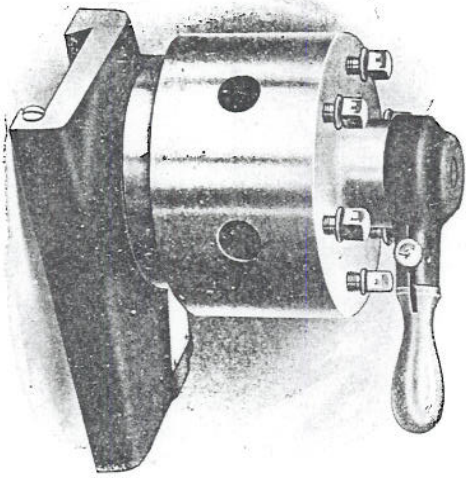

Style A

Carriage Turrets

Style "A" or round type is designed for boring, tapping, reaming and forming operations, using tools with round shanks.

It can be furnished with four or six holes.

A dowel pin through the base of the turret into the carriage serves to readily locate the turret in exact alignment with the lathe spindle. This pin can be withdrawn when it is desired to use the cross feed, for facing up work with the turret.

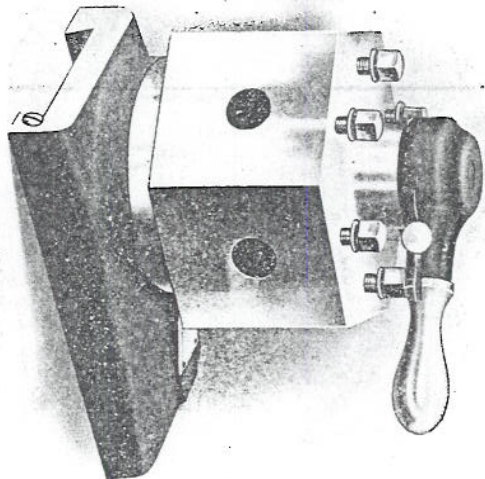

Style B

Carriage Turrets

Style "B" has hexagon head and the faces can be drilled to jig, for bolting on special tools or fixtures. Otherwise, the turret is same as style "A."

The same cross feed nut as used on the regular tool rest can be applied to any of these turrets.

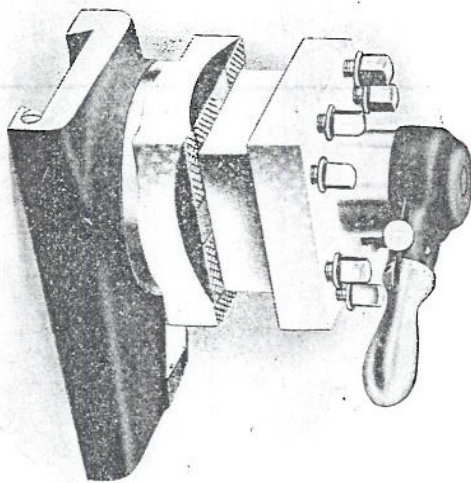

Style C

Carriage Turrets

This Four Sided Turret Tool Post carries ordinary lathe tools, and is the one we recommend for a general class of work, such as turning, boring, threading, etc.

It can be used for carrying special forming tools, in fact, performing the same functions as the ordinary tool post.

Its advantage is having four tools, always in position to be brought quickly into successive operation.

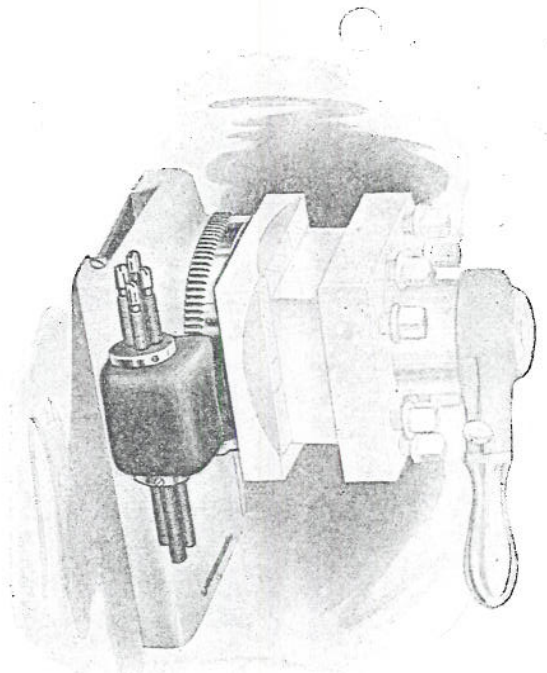

Diameter Stops

The Diameter Stop, illustrated above, is automatic in action, taking movement from the revolving turret head and provides for a positive independent feed stop for each face of the turret.

This stop is applicable to any style carriage turret shown on preceding page. It consists of a disc in which is located a series of adjustable stop screws, corresponding to the number of faces on the turret. By the revolving of the turret, these screws are brought into consecutive position to engage a lug on the side of the carriage.

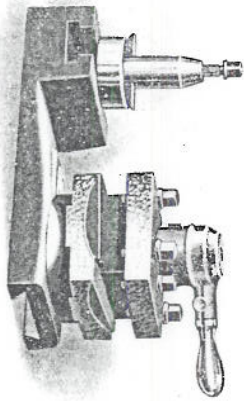

Style II

Carriage Turrets

Style "H" is designed particularly for working on bar stock. It is arranged with a single tool holder on the back. Otherwise, this turret is the same as style "G."

This turret is especially adapted to duplicate operations, the four slots in the turret head being available for turning or forming tools, then the rear tool can be quickly brought up, to square up shoulders, or for necking and cutting off.

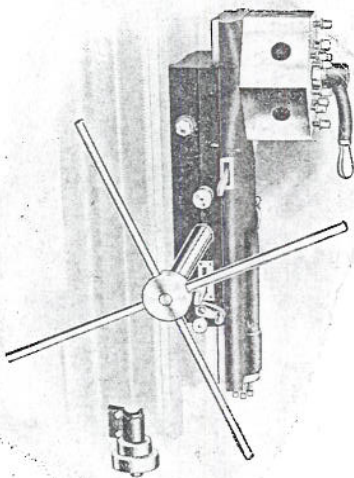

Bed Turrets

The Turret Base takes bearing upon the inner shears of the bed. Eccentric clamps, located at either end, serve to hold the turret in any desired position on the bed.

The top slide is of ample width and depth, forming a rigid support for the revolving head. It slides in a dovetailed type of bearing, having adjustable taper gibs. This construction has fewer bearing surfaces, a truer bearing is maintained and adjustments for wear are more readily made.

Monarch Universal Relieving Attachment

For use on 14", 16", 16" Heavy Duty, 18" and 20" Monarch Lathes, either cone head or geared head.

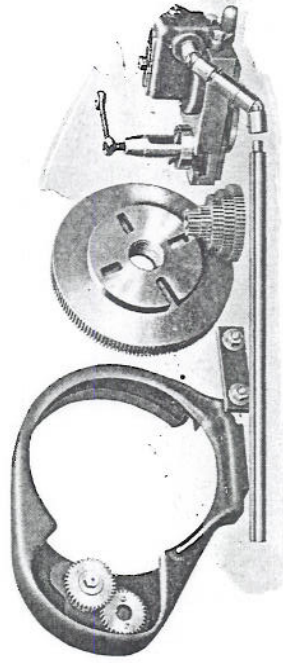

This attachment can be applied to any Monarch Lathe of the above sizes after shipment from the factory. No machine work or special parts are required. The Attachment is quickly fitted to any Monarch Lathe now in use.

SPECIAL FEATURES OF THE MONARCH UNIVERSAL RELIEVING ATTACHMENT

- 1—Attaches quickly to any Monarch Lathe without fitting or machine work.
- 2—Does every kind of relieving, except spiral relieving.
- 3—Has an unlimited range for angular relief.
- 4—Is quickly changed from relieving to plain turning or threading, or vica-versa.
- 5—Is simple and strong in construction.
- 6—Has graduated scale for amount of relief from 0 to 9-32".
- 7—Diameter of work which can be relieved 14" lathe—5" dia.
16" lathe—6" dia.
18" lathe—8" dia.
20" lathe—9" dia.
- 8—Change gears provide quick means of changing for a wide range of flutes or teeth.

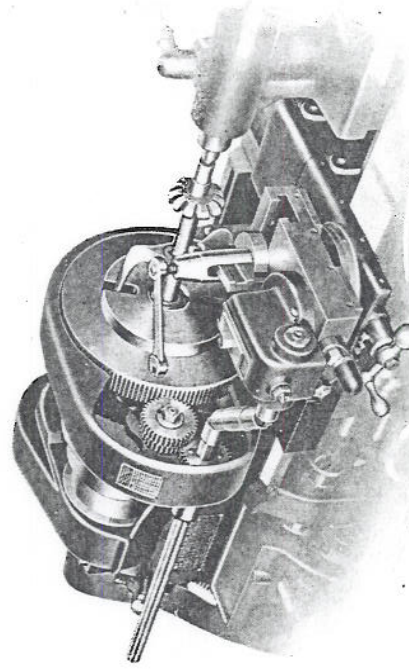

Relieving a Formed Cutter

Monarch Universal Relieving Attachment (Continued)

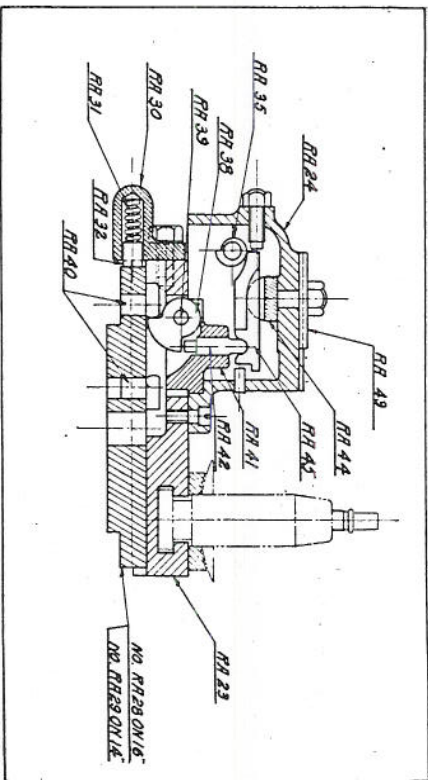

Sectional Drawing of Tool Slide and Actuating Mechanism

No. 43 is the Hood Plate fitting in a milled slide in the top of the hood housing. This is graduated so operator can accurately set for desired depth of relief.

No. 24 is the "Hood" housing the actuating mechanism and is of cast iron.

No. 35 is the hardened steel cam with single throw to which is pinned the main driving shaft. A shear pin is used at this point to protect the cam should the lathe be accidentally reversed. The advantage of a single throw cam from an accuracy standpoint is self evident.

No. 44 is the hardened steel Rocker Fulcrum, which is moved forward or backward in connection with No. 43 in securing various depths of relief.

No. 41 is the steel "Rocker Flange" which must be reversed when No. 30 spring box is placed on the rear of tool slide for inside relieving.

No. 42 is the hardened steel "Plunger" which is pressed down by No. 45 and in turn operates Rocker Crank No. 38 against abutting pin No. 40 in the bottom swivel. This gives the tool slide its movement.

No. 38 is the Rocker Crank of hardened steel which actuates against left hand abutting Pin No. 40 for regular relieving and when reversed actuates against right hand Abutting Pin for internal relieving.

No. 39 is the hardened Steel Pin holding No. 38 in position in No. 41.

No. 30 is Spring Box containing resisting spring No. 31 and spring plug No. 32. This is placed on the rear of the tool slide for inside relieving.

No. 23 is Tool Slide.

No. 28 is the Swivel which fits readily on the regular cross slide of the carriage.

All operating parts are made of the best grade of tool steel hardened. The Monarch Relieving Attachment will give universal satisfaction for all classes of relieving within its range.

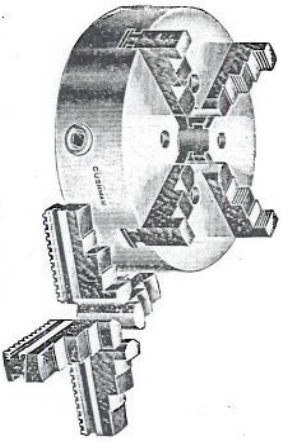

Fig. 5

4-Jaw Universal Chuck



Fig. 6

Drill Chuck

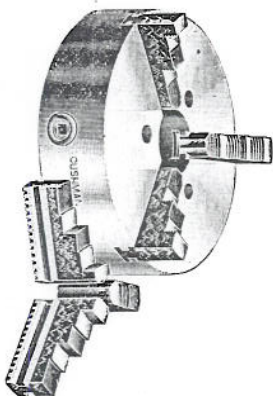

Fig. 7

3-Jaw Universal Chuck

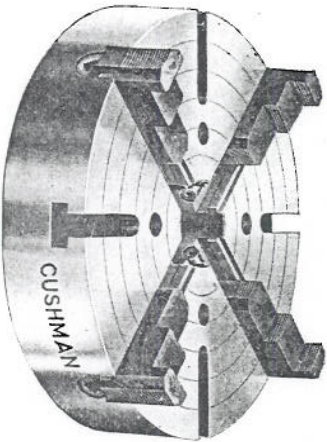

Fig. 8

4-Jaw Independent Chuck

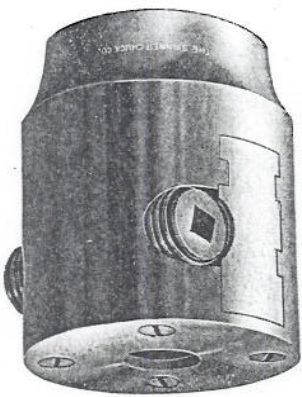

Fig. 9

Drill Chuck

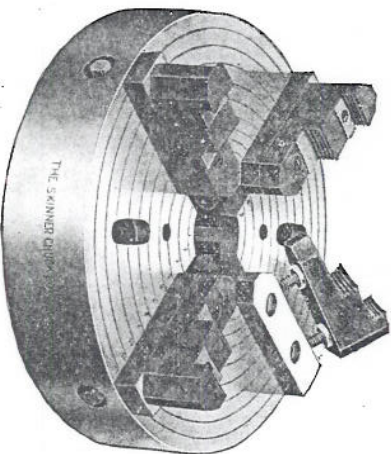

Fig. 10

**4-Jaw Independent Chuck
With Reversible Jaws**

We are in position to furnish any size, style or make of chuck from our stock, and will be glad to quote you prices on these chucks properly fitted to plate or taper plug and ready for use on any MONARCH lathe. Only a few of the many sizes and styles are listed here.

Chuck plates, fitted to spindle, can be furnished for any of our lathes.

List of Parts for MONARCH LATHEES

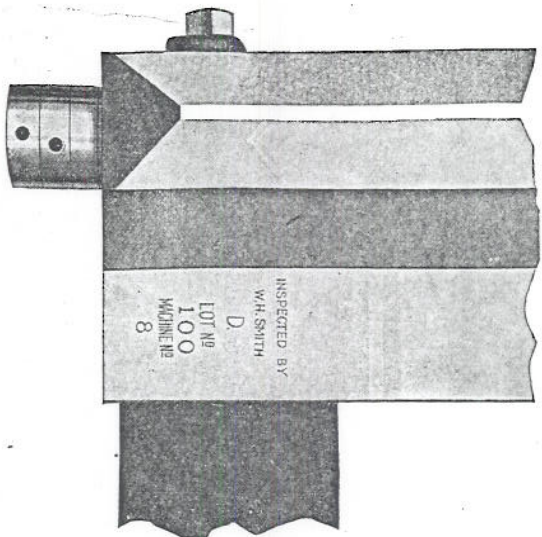

The following illustrations of parts of MONARCH lathes are not of any particular size lathes, but for all sizes. Simply compare the part desired with the illustration and the description of the part, and give us the number of the part. The most important part of any order for repairs is the SERIAL NUMBER, consisting of one letter, the lot number and the machine number, and must be included with every order. This SERIAL NUMBER is stamped on the tail end of the bed. See above illustration.

This offers the only means of informing us of the size or style of the lathe, and is absolutely necessary before any orders for repairs or accessories can be filled.

When ordering any part, always include the complete Serial Number of the lathe.

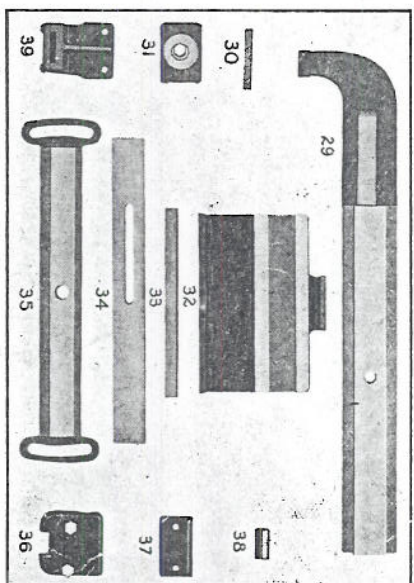

Taper Attachment

- 29—Horn
- 30—Slide Gib
- 31—Slide
- 32—Bracket
- 33—Bracket Gib
- 34—Bar
- 35—Swivel
- 36—Upper Half Dog
- 37—Lower Half Dog
- 38—Swivel Stud
- 39—Bar Support

Single E-10.25

*B-
Revise plate complete 4/9/15*

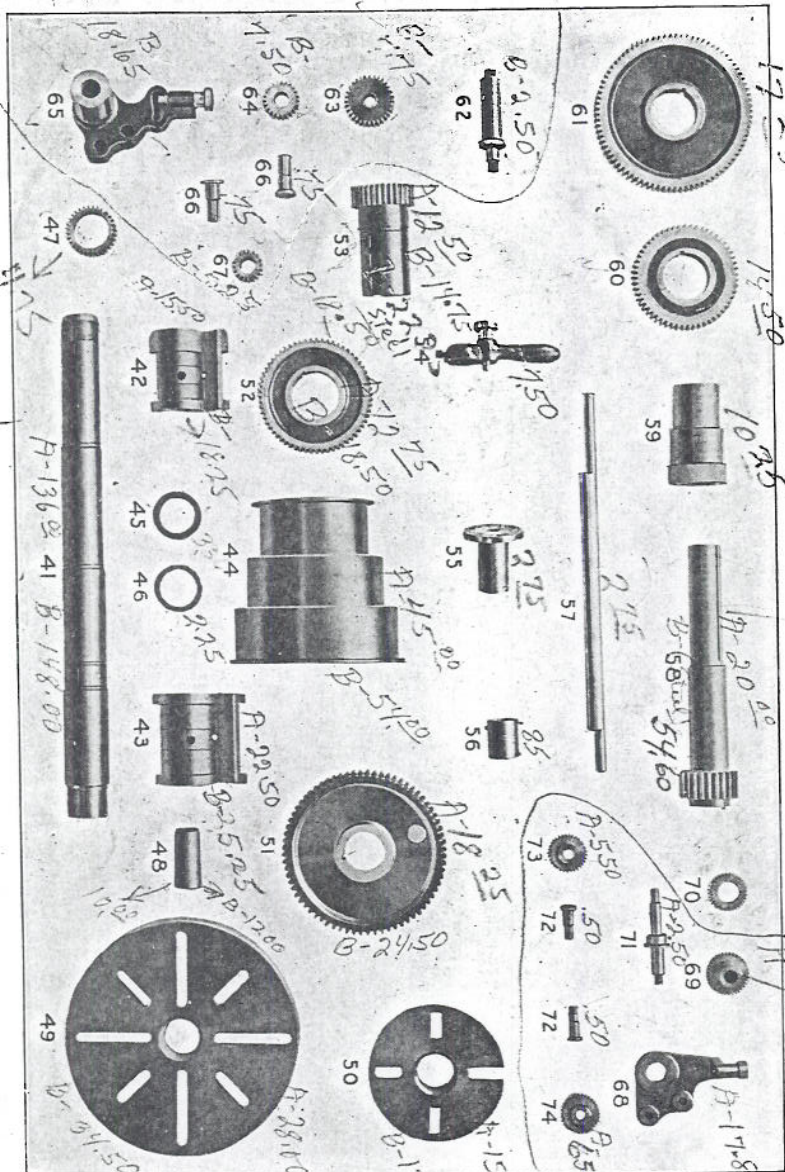

*Revise plate
complete 3/7/15*

When ordering any part, always include the complete Serial Number of the lathe.

Spindle Mounting 1.28

Headstock

- 41—Spindle
- 42—Rear Bearings
- 43—Front Bearings
- 44—3-Step Cone
- 45—Spindle Nut
- 46—Spindle Collar
- 47—Spindle Gear
- 48—Spindle Collar
- 49—Face Plate
- 50—Dog Plate
- 51—Face Gear
- 52—Cone Gear
- 53—Cone Pinion
- 54—Back Gear Handle
- 55—Flanged Bushing
- 56—Plain Bushing
- 57—Eccentric Shaft
- 58—Quill
- 59—Sliding Sleeve
- 60—Small Back Gear
- 61—Large Back Gear
- 62—Reverse Plate Stud
- 63—Stud Gear
- 64—Large Tumbler Gear
- 65—Reverse Plate
- 66—Tumbler Gear Stud
- 67—Small Tumbler Gear
- 68—Reverse Plate
- 69—Stud Gear
- 70—Stud Pinion
- 71—Reverse Plate Stud
- 72—Tumbler Gear Stud
- 73—31T Tumbler Gear
- 74—33T Tumbler Gear

Gear Box Feed Parts

- 75 - Quadrant Gear
- 76 - Quadrant Gear Bushing
- 77 - Upper Gear Box Stud
- 78 - Upper Gear Box Lever
- 79 - Upper Gear Box Lever Stud
- 80 - Quadrant
- 81 - Front Lead Screw Bearing
- 82 - Lower Gear Box Lever
- 83 - Lower Gear Box Lever Stud
- 84 - 24T Drive Gear
- 85 - 44T Drive Gear
- 86 - Lower Shaft Gear
- 87 - Lower Shaft Gear L. S. only gear
- 88 - 49T Cone Gear
- 89 - 16T Cone Gear
- 90 - 10T Cone Gear
- 91 - Sliding Collar
- 92 - 16T Cone Gear
- 93 - 32T Cone Gear
- 94 - 28T Cone Gear
- 95 - 26T Cone Gear
- 96 - 24T Cone Gear
- 97 - Lead Screw Gear
- 98 - Rear Lead Screw Bearing
- 99 - Thin Lead Screw Collar
- 100 - Lead Screw Collar
- 101 - Feed Screw Lock Nuts
- 102 - Upper Left G. B. Bearing
- 103 - Intermediate Left G. B. Bearing
- 104 - Lower Left G. B. Bearing
- 105 - Upper Right G. B. Bearing
- 106 - Intermediate Right G. B. Bearing
- 107 - Lower Right G. B. Bearing
- 108 - Intern. Intermediate Shaft Bearing
- 109 - Gear Box
- 110 - Upper Shaft
- 111 - Small Shaft
- 112 - Double Clutch Gear
- 113 - Large Clutch Gear
- 114 - Upper Shaft Gear
- 115 - Feed Rod Gear
- 116 - Index Rod Gear
- 117 - Slip Plate
- 118 - Slip Gear
- 119 - Front Bar with Pinion
- 120 - Rear Bearing for Automatic Stop
- 121 - Spring Collar
- 122 - Feed Rod Gear
- 123 - Spring
- 124 - Clutch with Sleeve
- 125 - Clutch
- 126 - Stop Collar
- 127 - Stop Collar

S. only gear

When ordering any part, always include the complete Serial Number of the lathe.

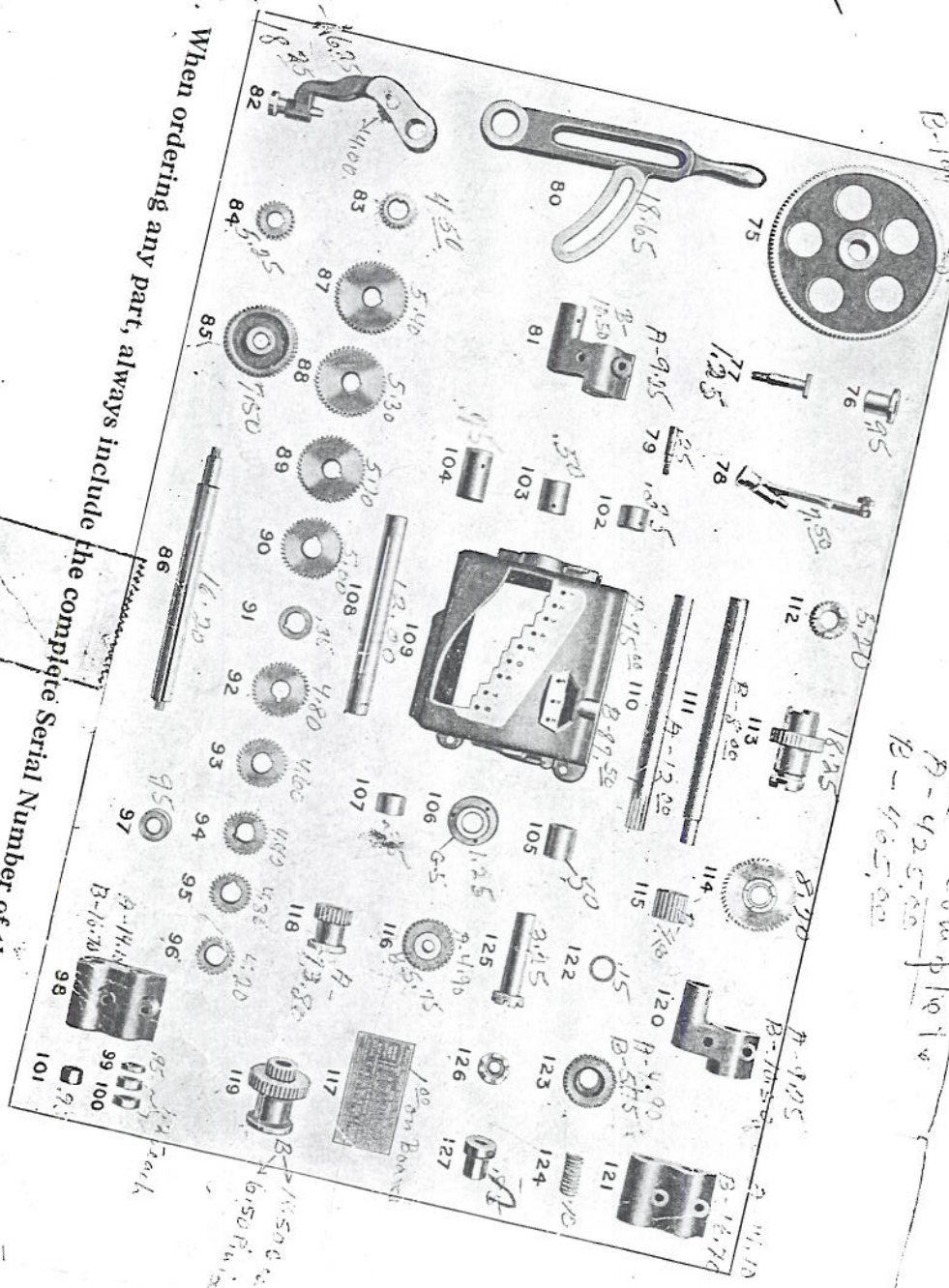

Gear Box Complete

A-425.00

P-18.50

1.50

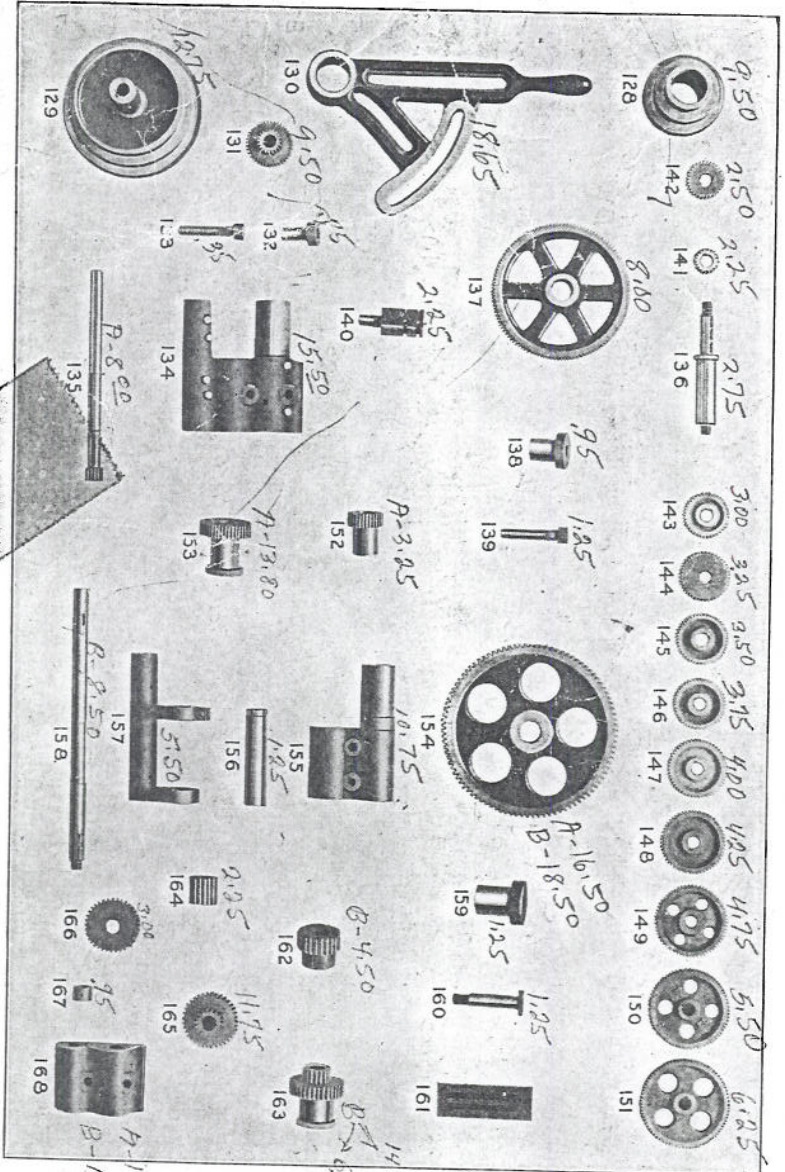

When ordering any part, always include the complete Serial Number of the lathe.

Standard Feed Parts

- 128—Spline Feed Cone
- 129—Feed Rod Cone
- 130—Quadrant
- 131—Compound Gear
- 132—Compound Gear Bushing
- 133—Front Bearing
- 134—Feed Cone Shaft
- 135—Reverse Plate Stud
- 136—Quadrant Gear Bushing
- 137—Quadrant Gear Stud
- 138—Hinter Stud
- 139—20T Change Gear
- 140—32T Change Gear
- 141—40T Change Gear
- 142—44T Change Gear
- 143—46T Change Gear
- 144—48T Change Gear
- 145—52T Change Gear
- 146—57T Change Gear
- 147—60T Change Gear
- 148—64T Change Gear
- 149—72T Change Gear
- 150—80T Change Gear
- 151—Lead Screw Gear
- 152—Feed Rod Slip Gear
- 153—Quadrant Gear
- 154—Lead Screw Bearing
- 155—Feed Rod Bearing
- 156—Feed Cone Hanger
- 157—Feed Cone Shaft
- 158—Quadrant Gear Bushing
- 159—Quadrant Gear Stud
- 160—Index Plate
- 161—Lead Screw Gear
- 162—Feed Cone Shaft Gear
- 163—Compound Gear for Fine Feed
- 164—Feed Rod Collar
- 165—Rear Bearing
- 166—Rear Bearing
- 167—Rear Bearing
- 168—Rear Bearing

A. 29—A 4.50 Steel Rod Gear

Carriage

- 169—Carriage
- 170—Front Carriage Clamp
- 171—Back Carriage Gib
- 172—Slide
- 173—Slide Gib
- 174—Swivel Stud
- 175—Swivel
- 176—Top Block
- 177—Top Block Gib
- 178—Compound Screw Bushing
- 179—Graduated Collar
- 180—Compound Screw
- 181—Compound Ball Crank
- 182—Cover
- 183—Cross Feed Ball Crank
- 184—Cross Feed Gear
- 185—Cross Feed Screw
- 186—Cross Feed Graduated Collar
- 187—Cross Feed Screw Bushing
- 188—Graduated Collar Bushing
- 189—Cross Feed Screw Nut
- 190—Swivel Bolt
- 191—Follower Head Apron Screws
- 192—Back Clamp Screw
- 193—Tool Post Wrench
- 194—Compound Wrench
- 195—Chasing Dial Bracket
- 196—Chasing Dial Stem
- 197—Chasing Dial Worm Gear
- 198—Tool Post Collar
- 199—Tool Post Rocker
- 200—Tool Post Screws
- 201—Tool Post

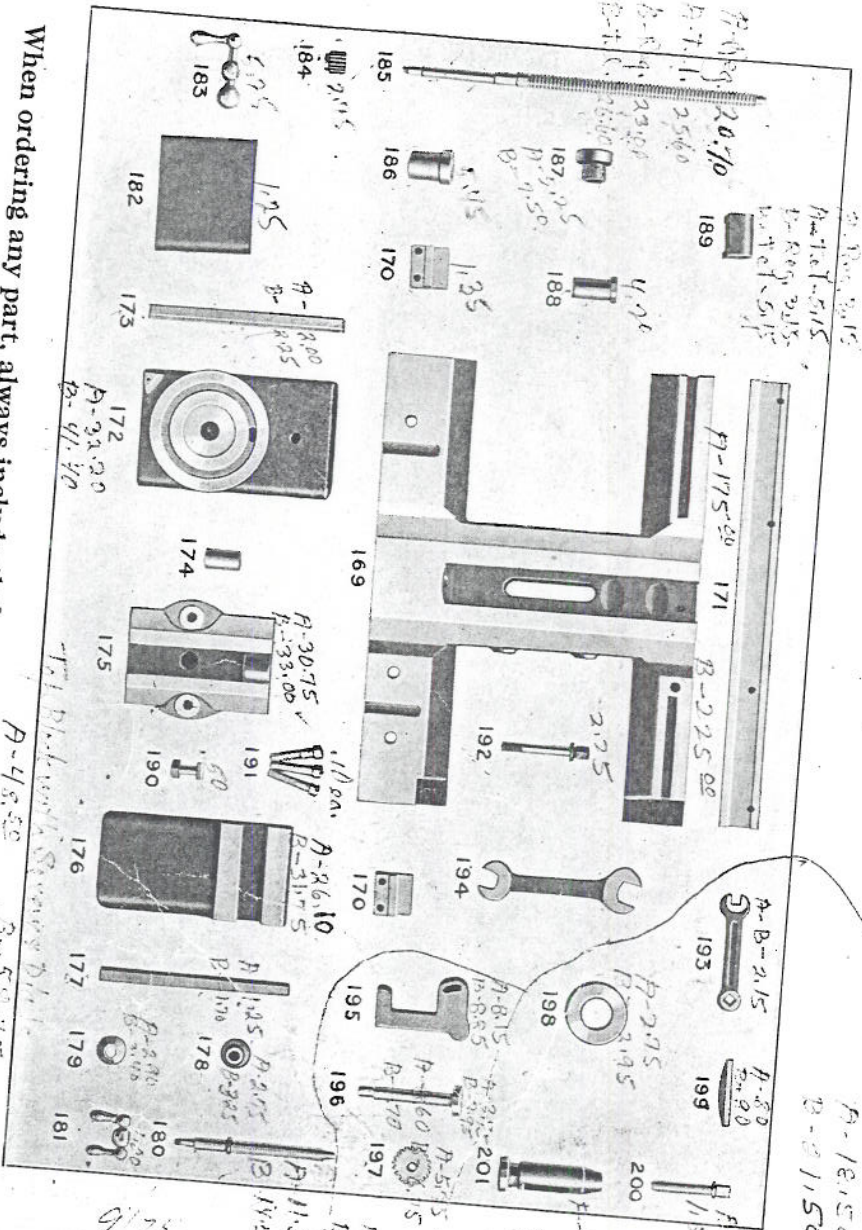

When ordering any part, always include the complete Serial Number of the lathe.

Complete
12-50

When ordering any part, always include the complete Serial Number of the lathe.

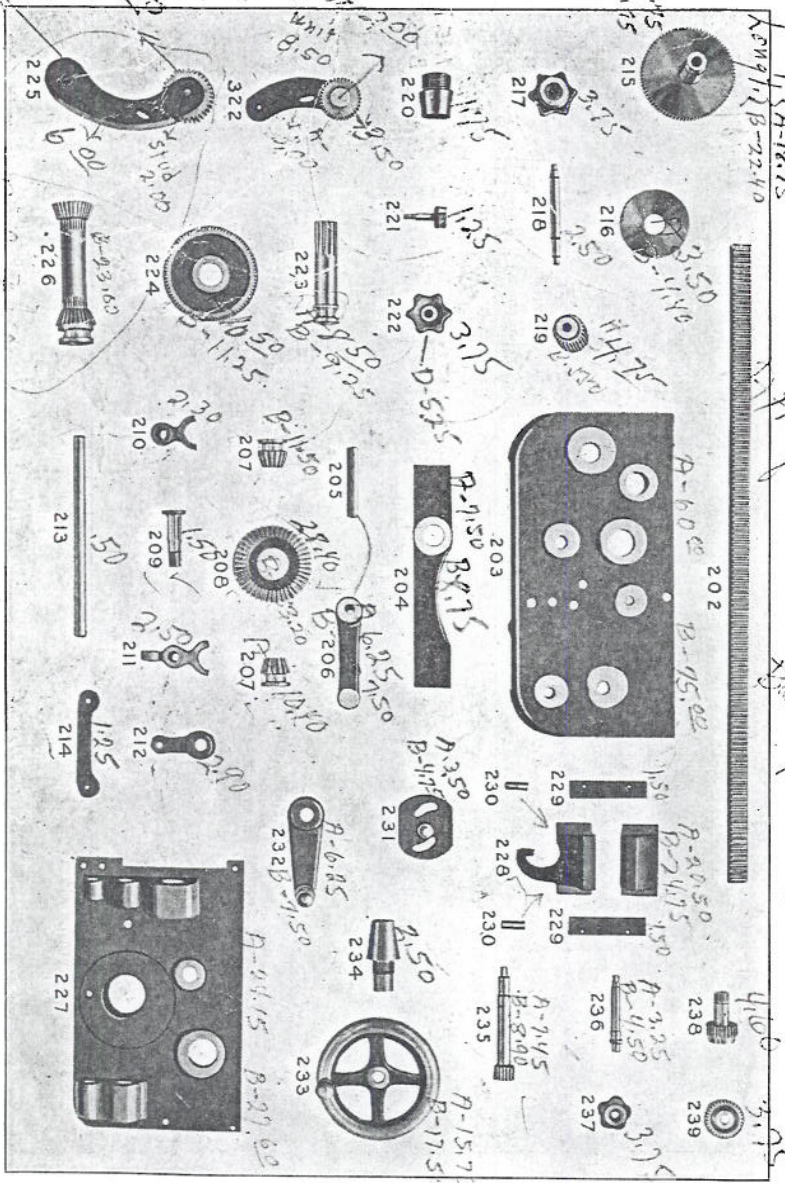

34th gear on axle for turning a part

D-3115

Apron

- 202—Rack
- 203—Apron Casting
- 204—Rack Pinion Support
- 205—Reverse Lever Stud
- 206—Reverse Lever
- 207—Bevel Pinions
- 208—Bevel Gear with Pinion
- 209—Bevel Gear Stud
- 210—Reverse Finger
- 211—Reverse Finger with Arm
- 212—Reverse Finger Lever
- 213—Reverse Finger Shaft
- 214—Reverse Finger Link
- 215—Friction Gear
- 216—Friction Plate
- 217—Friction Knob
- 218—Friction Gear Stud
- 219—Friction Gear Pinion
- 220—Friction Gear Bushing
- 221—Eccentric Pin
- 222—Cross Feed Knob
- 223—Cross Feed Link
- 224—Rack Pinion
- 225—Rack Gear
- 226—Cross Feed Link
- 227—Double Bevel Pinion
- 228—Apron Back Plate
- 229—Half Nut
- 230—Half Nut Guides
- 231—Cam Plate with Stud
- 232—Half Nut Lever
- 233—Apron Handwheel
- 234—First Stud Bushing
- 235—First Stud
- 236—Friction Stud
- 237—Friction Cross Feed Knob
- 238—Friction Sleeve Gear
- 239—Friction Gear

Approved 12-19-20
D-5115

Tailstock

- 240—Lug
- 241—Binder Handle
- 242—Binder Plug
- 243—Binder Stud
- 244—Spindle
- 245—Clamp Bolts
- 246—Set Over Screws
- 247—Clamp
- 248—Handwheel
- 249—Tailstock Screw
- 250—Bell
- 251—Wrench
- 253—Follow Rest
- 254—Adjusting Screws
- 255—Jaw Screw
- 255—Jaw
- 254—Steady Rest Bolt
- 257—Steady Rest Jaw Screws
- 258—Steady Rest Clamp
- 256—Eye Bolt
- 260—Hinge Bolt
- 261—Steady Rest Jaws
- 262—Adjusting Screws
- 263—Upper Half Steady Rest
- 264—Lower Half Steady Rest
- 265—Tailstock
- 266—Tailstock Base

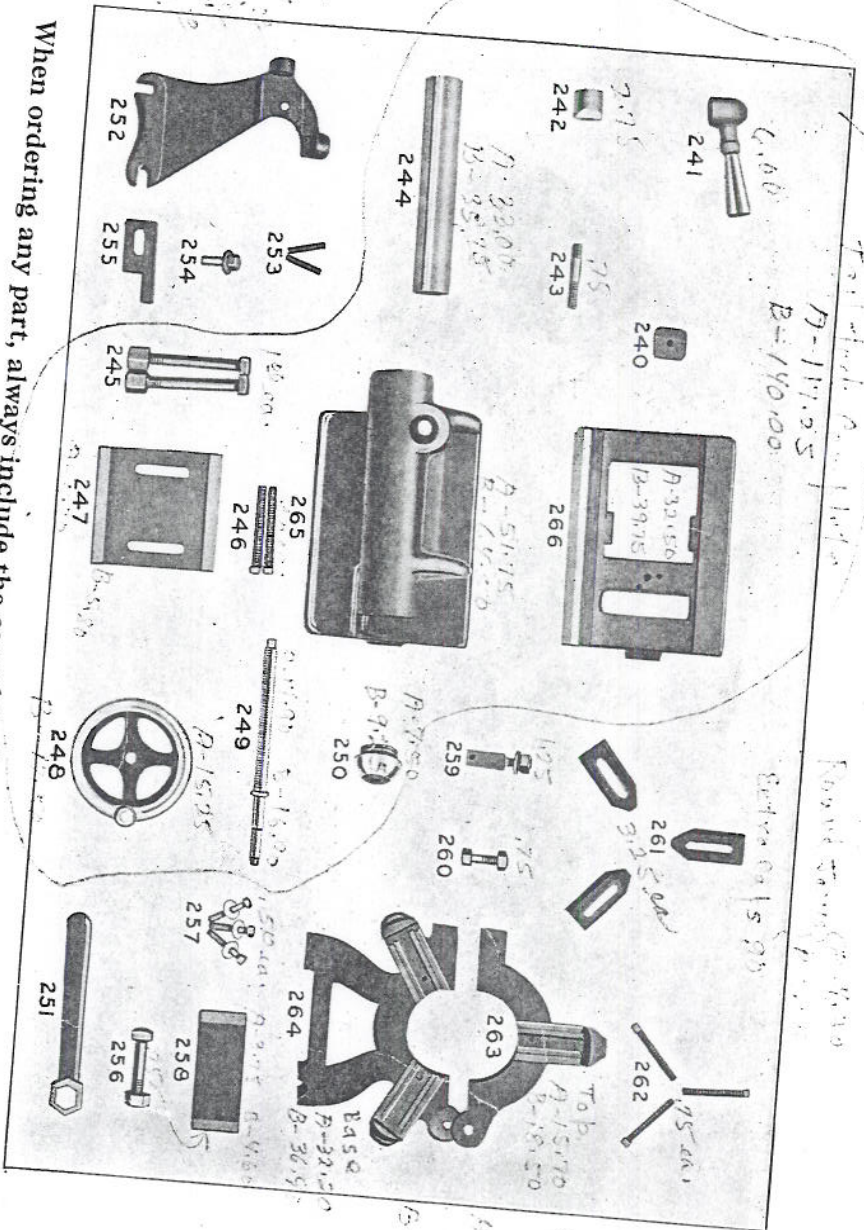

When ordering any part, always include the complete Serial Number of the lathe.

When ordering any part, always include the complete Serial Number of the lathe.

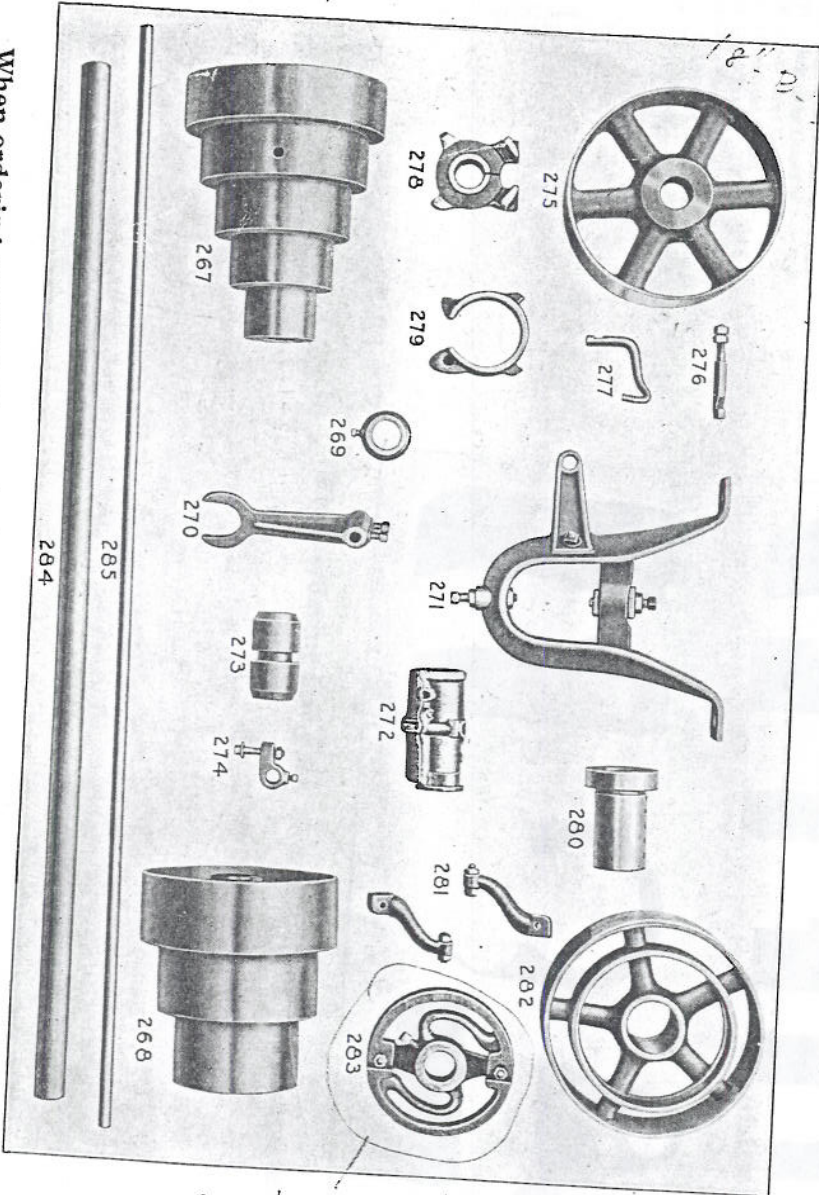

*fits in #282, int #282
chain drive instead of belt drive.*

Countershaft

- 267—Five Step Cone
- 268—Three Step Cone
- 269—Collar
- 270—Shifter Fork
- 271—Hanger Complete
- 272—Bearing
- 273—Spool
- 274—Shifting Link
- 275—Conway Clutch Pulley
- 276—Conway Eye Bolt
- 277—Conway Clutch Finger
- 278—Conway Clutch Dog
- 279—Conway Clutch Hand
- 280—Edgemont Clutch Pulley Bushing
- 281—Edgemont Clutch Fingers
- 282—Edgemont Clutch Pulley
- 283—Edgemont Clutch
- 284—Shaft
- 285—Shifter Rod

When ordering any part, always include the complete Serial Number of the lathe.

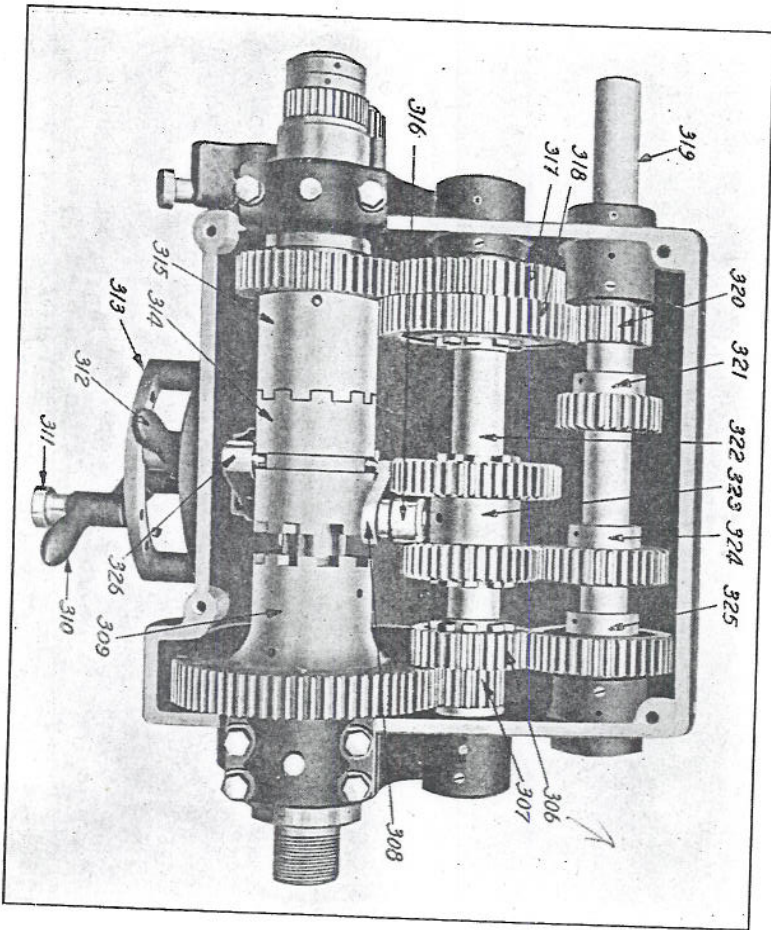

Geared Head Parts

- 306—Right Intermediate Shaft Clutch Gear
- 307—Intermediate Shaft with Gear
- 308—Intermediate Clutch Lever Arm
- 309—Right Spindle Clutch Gear
- 310—Intermediate Clutch Operating Lever
- 311—Plunger Knob
- 312—Spindle Clutch Operating Lever
- 313—Operating Lever Segment
- 314—Sliding Spindle Clutch
- 315—Left Spindle Clutch Gear
- 316—Clutch Arm Roller
- 317—Left Intermediate Shaft Gear
- 318—Left Intermediate Shaft Clutch Gear
- 319—Drive Shaft
- 320—First Drive Shaft Gear
- 321—Second Drive Shaft Gear
- 322—Intermediate Shaft
- 323—Double Clutch Gear
- 324—Third Drive Shaft Gear
- 325—Fourth Drive Shaft Gear
- 326—Spindle Clutch Lever Arm

(U V X Y Z)

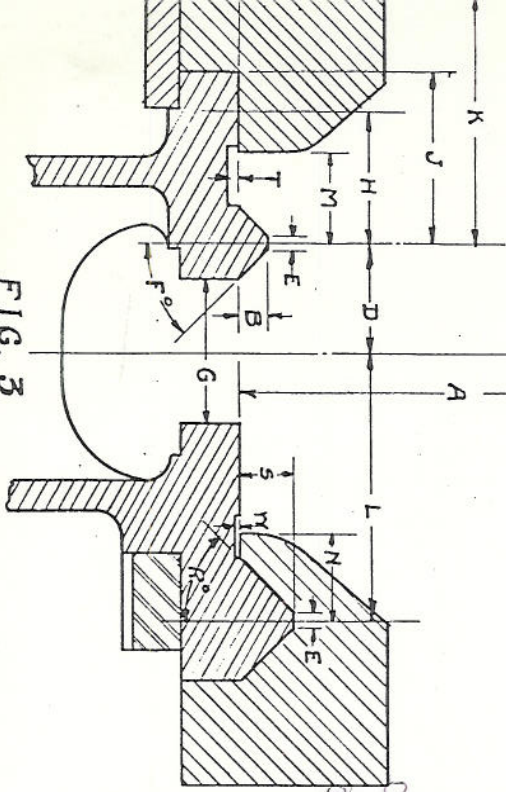
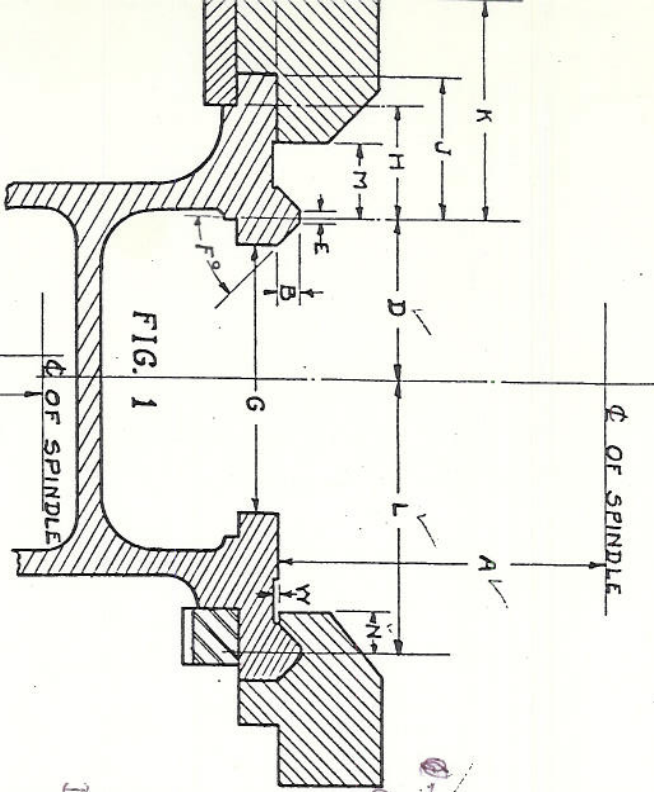
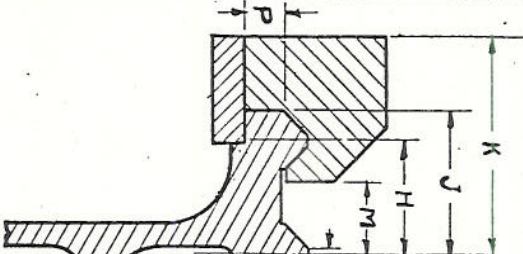

	FIG. 1 AND FIG. 2										FIG. 3		FIG. 1 AND 2		FIG. 3		FIG. 1 AND 2		
SIZE LATHES	9	10	11	12	14	16	17	18	20	22	24	24	24	24	26	28	30	30	30
A	$4\frac{1}{2}$	$5\frac{1}{8}$	$5\frac{3}{16}$	6	$7\frac{1}{8}$	8	$8\frac{3}{8}$	$8\frac{1}{2}$	$9\frac{1}{16}$	$11\frac{1}{4}$	$12\frac{3}{8}$	$12\frac{3}{8}$	$11\frac{3}{4}$	$11\frac{3}{4}$	$12\frac{7}{8}$	14	$15\frac{1}{8}$	$15\frac{1}{8}$	$15\frac{1}{8}$
B	$\frac{1}{4}$	$\frac{1}{32}$	$\frac{1}{4}$	$\frac{1}{32}$	401	401	$\frac{5}{8}$	$\frac{9}{16}$	$\frac{9}{16}$	$\frac{5}{4}$	$\frac{3}{4}$	$\frac{3}{4}$	$\frac{1}{2}$	$\frac{3}{4}$	$\frac{1}{2}$	$\frac{1}{2}$	$\frac{1}{2}$	$\frac{1}{2}$	$\frac{1}{2}$
D	$2\frac{5}{8}$	$2\frac{1}{2}$	$2\frac{5}{8}$	$2\frac{1}{2}$	$3\frac{3}{8}$	$3\frac{3}{8}$	$4\frac{3}{8}$	$4\frac{1}{2}$	$4\frac{1}{2}$	5	5	5	$6\frac{1}{2}$	6	6	6	6	6	6
E	$\frac{1}{8}$	$\frac{3}{16}$	$\frac{1}{8}$	$\frac{3}{16}$	$\frac{1}{4}$	$\frac{1}{4}$	$\frac{1}{4}$	$\frac{3}{16}$	$\frac{3}{16}$	$\frac{1}{4}$	$\frac{1}{4}$	$\frac{1}{4}$	$\frac{1}{4}$	$\frac{1}{4}$	$\frac{3}{16}$	$\frac{3}{16}$	$\frac{3}{16}$	$\frac{3}{16}$	$\frac{3}{16}$
F	45°	45°	45°	45°	45°	45°	45°	45°	45°	45°	45°	45°	45°	45°	45°	45°	45°	45°	45°
G	$4\frac{3}{8}$	$4\frac{1}{8}$	$4\frac{3}{8}$	$4\frac{1}{8}$	5	5	$7\frac{1}{4}$	$7\frac{5}{8}$	$7\frac{5}{8}$	84	84	84	$94\frac{3}{4}$	$94\frac{3}{4}$	$94\frac{3}{4}$	$94\frac{3}{4}$	$94\frac{3}{4}$	$94\frac{3}{4}$	$94\frac{3}{4}$
H	$\frac{1}{16}$	$\frac{1}{4}$	$\frac{1}{16}$	$\frac{1}{4}$	$2\frac{1}{4}$	$2\frac{1}{4}$	$2\frac{1}{4}$	$2\frac{1}{2}$	$2\frac{1}{2}$	$2\frac{1}{4}$	$2\frac{1}{4}$	$2\frac{1}{4}$	$3\frac{1}{8}$	$3\frac{1}{8}$	$3\frac{1}{2}$	$3\frac{1}{2}$	$3\frac{1}{2}$	$3\frac{1}{2}$	$3\frac{1}{2}$
J	$\frac{1}{8}$	$2\frac{3}{16}$	$\frac{1}{8}$	$\frac{1}{8}$	$2\frac{7}{8}$	$2\frac{7}{8}$	$3\frac{1}{2}$	$3\frac{5}{8}$	$3\frac{5}{8}$	$3\frac{5}{8}$	$3\frac{5}{8}$	$3\frac{5}{8}$	$4\frac{3}{8}$	$4\frac{3}{8}$	$4\frac{3}{8}$	$4\frac{3}{8}$	$4\frac{3}{8}$	$4\frac{3}{8}$	$4\frac{3}{8}$
K	$2\frac{3}{8}$	$3\frac{3}{8}$	$2\frac{3}{8}$	$3\frac{3}{8}$	$4\frac{5}{16}$	$4\frac{5}{16}$	6	$4\frac{3}{8}$	$4\frac{3}{8}$	$6\frac{3}{4}$	$6\frac{3}{4}$	$6\frac{3}{4}$	$7\frac{7}{8}$	$7\frac{7}{8}$	$7\frac{7}{8}$	$7\frac{7}{8}$	$7\frac{7}{8}$	$7\frac{7}{8}$	$7\frac{7}{8}$
L	$3\frac{11}{16}$	$4\frac{1}{4}$	$3\frac{11}{16}$	$4\frac{1}{4}$	$5\frac{3}{8}$	$5\frac{3}{8}$	$7\frac{5}{8}$	7	7	$8\frac{1}{8}$	$8\frac{1}{8}$	$8\frac{1}{8}$	$9\frac{1}{2}$	$9\frac{1}{2}$	$9\frac{1}{2}$	$9\frac{1}{2}$	$9\frac{1}{2}$	$9\frac{1}{2}$	$9\frac{1}{2}$
M	$3\frac{3}{4}$	$\frac{1}{8}$	$\frac{1}{8}$	$\frac{3}{4}$	$\frac{1}{8}$	$\frac{1}{8}$	$\frac{7}{8}$	$\frac{1}{8}$	$\frac{1}{8}$	$\frac{1}{8}$	$\frac{1}{8}$	$\frac{1}{8}$	2	2	2	2	2	2	2
N	$\frac{1}{2}$	$\frac{5}{8}$	$\frac{1}{2}$	$\frac{1}{2}$	$\frac{13}{16}$	$\frac{13}{16}$	$\frac{1}{4}$	$\frac{7}{8}$	$\frac{7}{8}$	$\frac{1}{8}$	$\frac{1}{8}$	$\frac{1}{8}$	$\frac{1}{8}$	$\frac{1}{8}$	$\frac{1}{8}$	$\frac{1}{8}$	$\frac{1}{8}$	$\frac{1}{8}$	$\frac{1}{8}$
P	$\frac{1}{2}$	$\frac{5}{8}$	$\frac{1}{2}$	$\frac{1}{2}$.851	.851	$\frac{1}{4}$	$\frac{1}{8}$	$\frac{1}{8}$	$\frac{3}{4}$	$\frac{3}{4}$	$\frac{3}{4}$	$\frac{1}{8}$	$\frac{1}{8}$	$\frac{1}{8}$	$\frac{1}{8}$	$\frac{1}{8}$	$\frac{1}{8}$	$\frac{1}{8}$
W	$\frac{1}{16}$	$\frac{1}{16}$	$\frac{1}{16}$	$\frac{1}{16}$	$\frac{1}{8}$	$\frac{1}{8}$	$\frac{1}{8}$	$\frac{1}{8}$	$\frac{1}{8}$	45°	45°	45°	45°	45°	45°	45°	45°	45°	45°
R																			
S																			
T							$\frac{1}{4}$			$\frac{1}{8}$	$\frac{1}{8}$	$\frac{1}{8}$							



10&12" GEARED HEADSTOCK PULLEY DRIVE.

LINE SHAFT RUNS - 250 R.P.M.
 DIA. OF PULLEY ON LINE SHAFT-12"
 DIA. OF PULLEY ON DRIVE SHAFT-8"
 DRIVE SHAFT RUNS - 375 R.P.M.
 GREATEST SPEED REDUCTION - 11.72 TO 1.

SPINDLE SPEEDS.

POSITION 1 - 32-R.P.M.	POSITION 5 - 144-R.P.M.
2 - 50-R.P.M.	6 - 225-R.P.M.
3 - 74-R.P.M.	7 - 335-R.P.M.
4 - 104-R.P.M.	8 - 468-R.P.M.

17-18-20" GEARED HEADSTOCK PULLEY DRIVE

LINE SHAFT RUNS - 250 R.P.M.
 DIA. OF PULLEY ON LINE SHAFT-16"
 DIA. OF PULLEY ON DRIVE SHAFT 14"
 DRIVE SHAFT RUNS - 285 R.P.M.
 GREATEST SPEED REDUCTION-19 TO 1.

SPINDLE SPEEDS.

POSITION-1- 158-R.P.M.	POSITION-5- 95-R.P.M.
2-28.5-R.P.M.	6-171-R.P.M.
3-42.8-R.P.M.	7-257.8-R.P.M.
4-55.1-R.P.M.	8-331.2-R.P.M.

14-16" GEARED HEADSTOCK PULL

LINE SHAFT RUNS - 250 R.P.M.
 DIA. OF PULLEY ON LINE SHAFT-12"
 DIA. OF PULLEY ON DRIVE SHAFT-10"
 DRIVE SHAFT RUNS - 300 R.P.M.
 GREATEST SPEED REDUCTION-12 TO 1.

SPINDLE SPEEDS.

POSITION-1-25.6-R.P.M.	POSITIC
2-40-R.P.M.	
3-59.5-R.P.M.	
4-83.3-R.P.M.	

24-26-28-30" GEARED HEA

LINE SHAFT RUNS - 250 R.P.M.
 DIA. OF PULLEY ON LINE SHAFT-12"
 DIA. OF PULLEY ON DRIVE SHAFT-18"
 DRIVE SHAFT RUNS-165 R.P.M.
 GREATEST SPEED REDUCTION 2.157

SPINDLE SPEEDS.

POSITION-1- 7.6-R.P.M.	POSITI
2-12.2-R.P.M.	
3-19-R.P.M.	
4-30.2-R.P.M.	

10" X 12" CONE HEAD LATHE
 THE MONARCH MACHINE TOOL CO.
 SIDNEY OHIO.

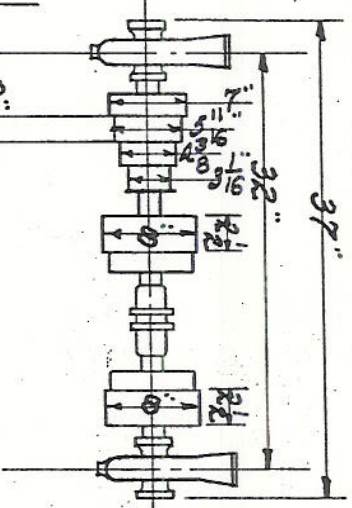
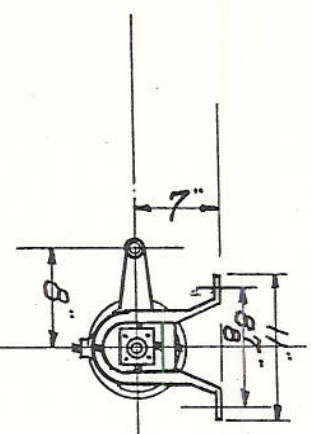

OVER ALL LENGTH
 4' BED 4'-7 1/2"
 5' " 5'-7 1/2"
 6' " 5'-7 1/2"
 10' BED 10'-7 1/2"
 9' " 9'-7 1/2"

MAXIMUM DISTANCE BETWEEN CENTERS
 4' BED - 1'-4 3/4"
 5' " 2'-4 3/4"
 6' " 3'-4 3/4"
 10' BED 7'-4 3/4"

10' LATHE 47 3/4"
 12' LATHE 48 5/8"
 10' LATHE 42 1/4"
 12' LATHE 43 1/8"

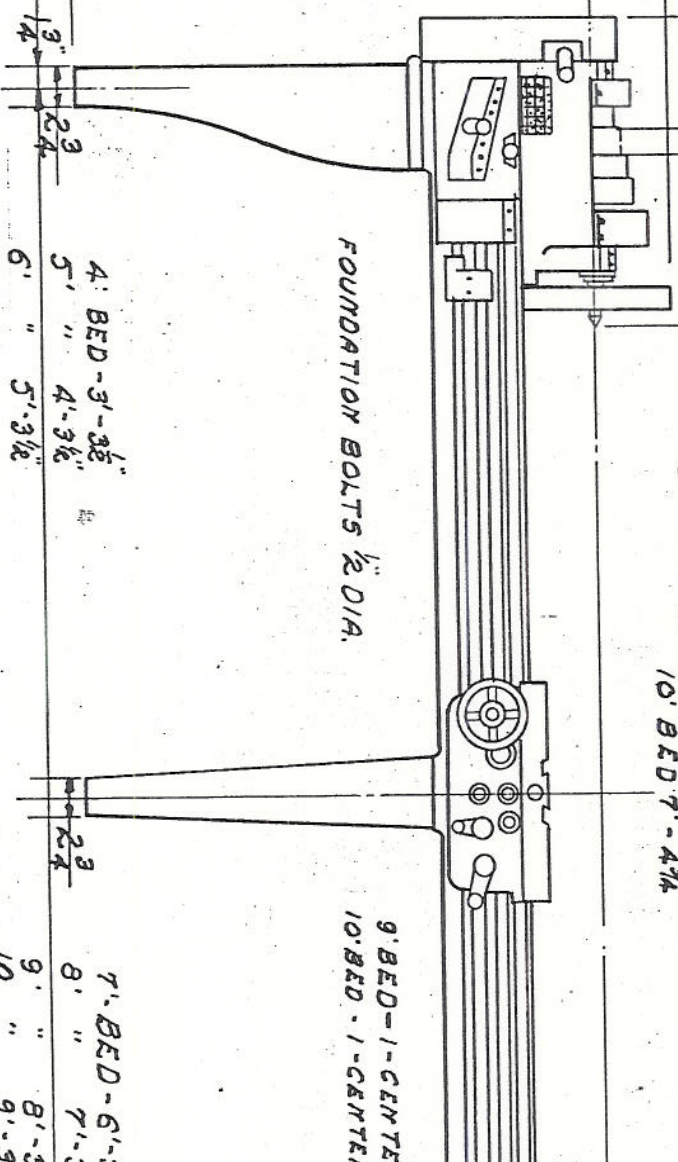

FOUNDATION BOLTS 1/2" DIA.

9' BED - 1-CENTRE
 10' BED - 1-CENTRE

4' BED - 3'-3 3/8"
 5' " 4'-3 3/8"
 6' " 5'-3 3/8"
 7' BED - 6'-1"
 8' " 7'-1"
 9' " 8'-1"
 10' " 9'-1"

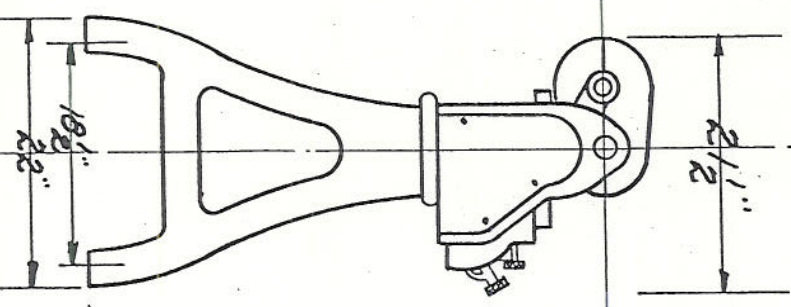

10" x 12" CONE HEAD LH.
THE MONARCH MACHINE TOOL
SIDNEY, OHIO

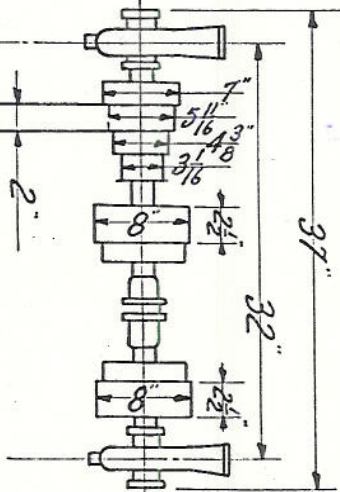
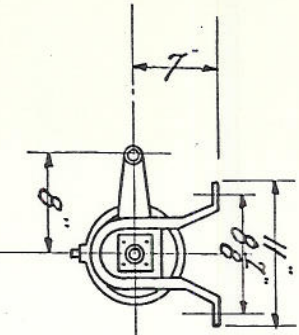

OVER HILL LENGTH

4' BED	4'-7 1/2"	7' BED	7'-7 1/2"
5' BED	5'-7 1/2"	8' BED	8'-7 1/2"
6' BED	6'-7 1/2"	9' BED	9'-7 1/2"
10' BED	10'-7 1/2"		

MINIMUM DISTANCE BETWEEN CENTERS

4' BED	1'-4 3/4"	7' BED	4'-4 3/4"
5' BED	2'-4 3/4"	8' BED	5'-4 3/4"
6' BED	3'-4 3/4"	9' BED	6'-4 3/4"
10' BED	7'-4 3/4"		

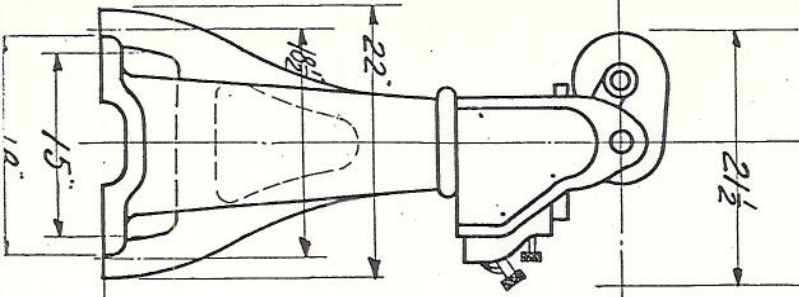

10' LATHE 47 3/4"
12' LATHE 48 5/8"
10' LATHE 42 1/4"
12' LATHE 43 3/8"

FOUNDATION BOLTS 1/2" DIA

4' BED	1'-6 3/4"
5' BED	2'-6 3/4"
6' BED	3'-6 3/4"
7' BED	4'-6 3/4"
8' BED	5'-6 3/4"
9' BED	6'-6 3/4"
10' BED	7'-6 3/4"

9' BED 1-CENT.
10' BED 1-CENT.

4' BED	2'-4 1/2"
5' BED	3'-4 1/2"
6' BED	4'-4 1/2"
7' BED	5'-4 1/2"
8' BED	6'-4 1/2"
9' BED	7'-4 1/2"
10' BED	8'-4 1/2"

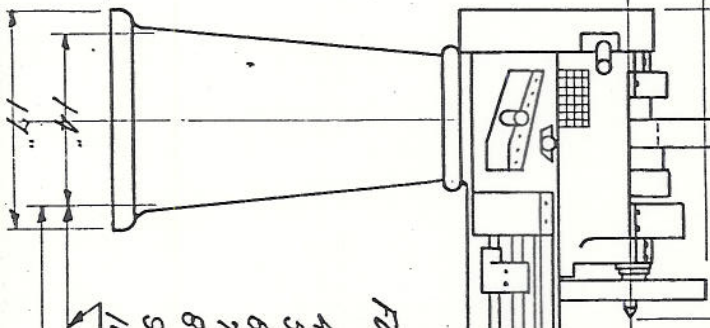

2 3/4"

10 1/2" MOTOR DRIVE. OUTLINE.

MONARCH MACHINE TOOL CO.
SIDNEY, OHIO.

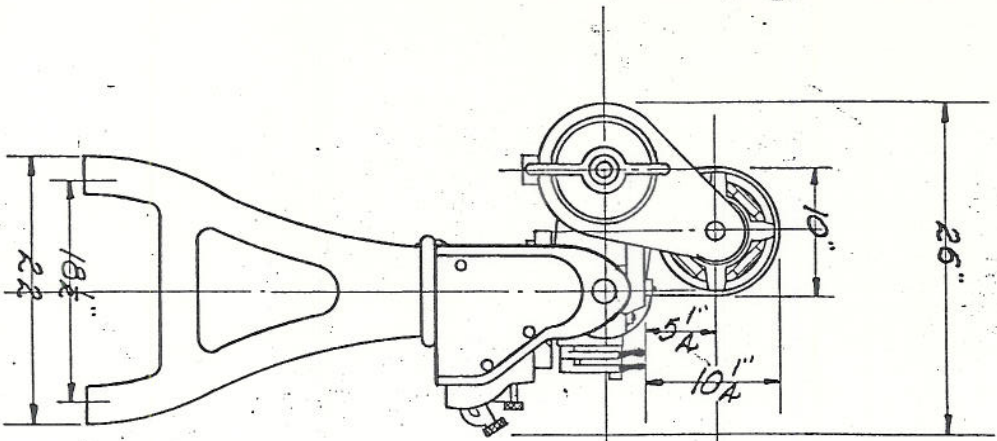

10" LATHE - 55 5/8"
12" LATHE - 56 1/2"
10" LATHE - 42 1/4"
12" LATHE - 43 1/8"

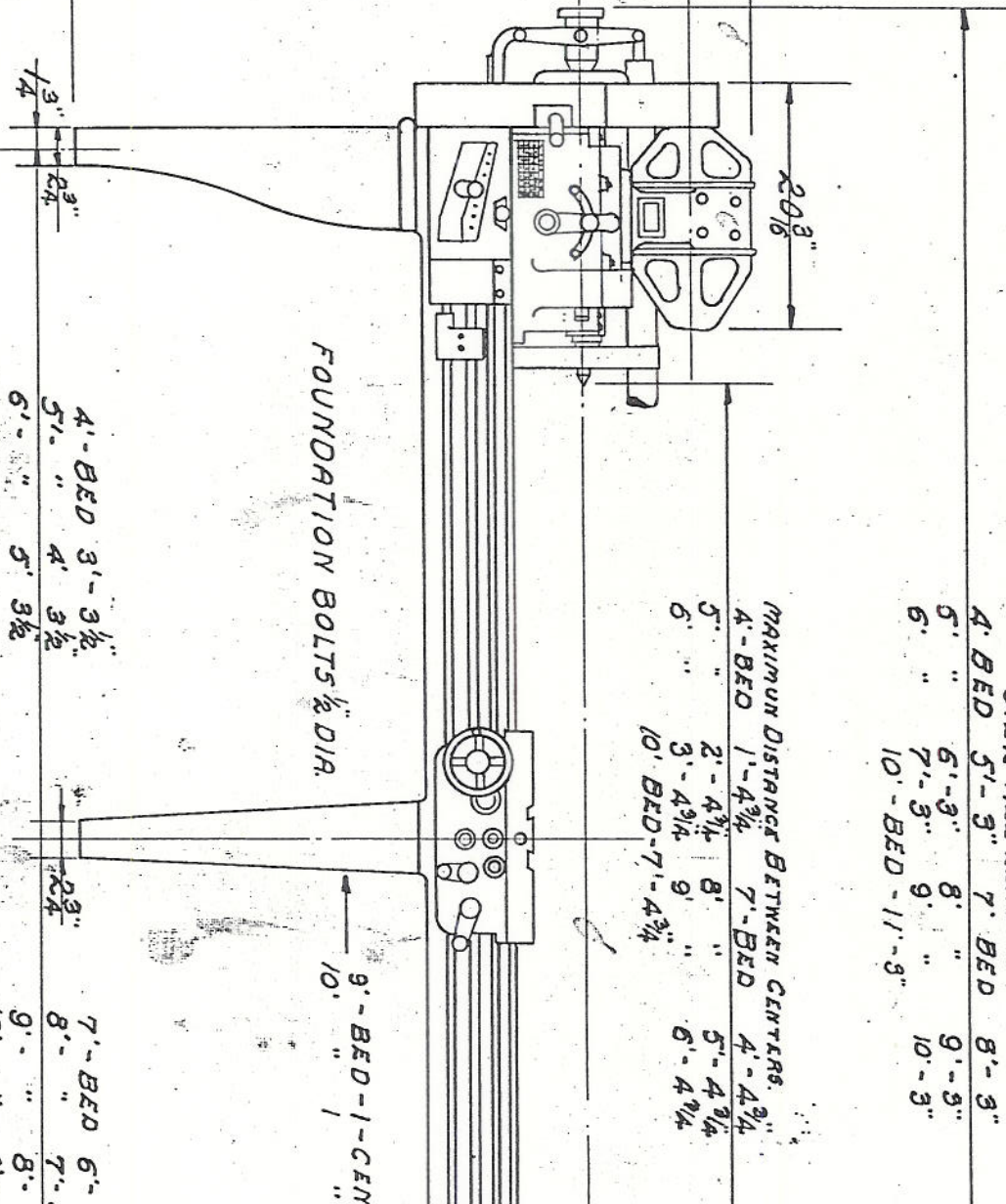

OVER ALL LENGTH.

4' BED	5'-3"	7' BED	8'-3"
5' "	6'-3"	8' "	9'-3"
6' "	7'-3"	9' "	10'-3"
10' BED	11'-3"		

MAXIMUM DISTANCE BETWEEN CENTERS.

4' BED	1'-4 3/4"	7' BED	4'-4 3/4"
5' "	2'-4 3/4"	8' "	5'-4 3/4"
6' "	3'-4 3/4"	9' "	6'-4 3/4"
10' BED	7'-4 3/4"		

FOUNDATION BOLTS 1/2" DIA.

9' - BED - 1 - CEN
10' " " " "

4' - BED	3'-3 1/2"	7' - BED	6'-"
5' "	4'-3 1/2"	8' "	7'-"
6' "	5'-3 1/2"	9' "	8'-"
		10' "	9'-"

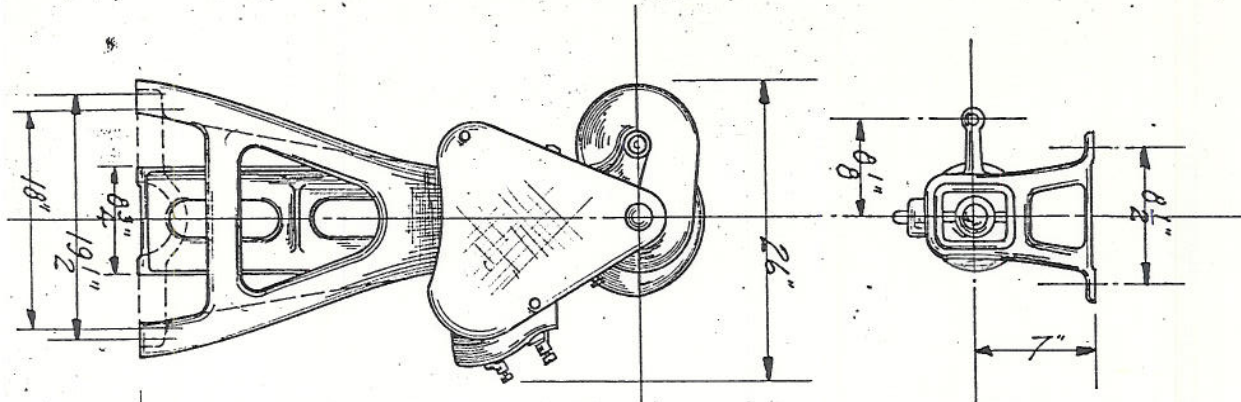

14" Lathe - 42 3/4"
 16" Lathe - 43 3/4"
 14" Lathe - 40 1/4"
 16" Lathe - 49 1/4"

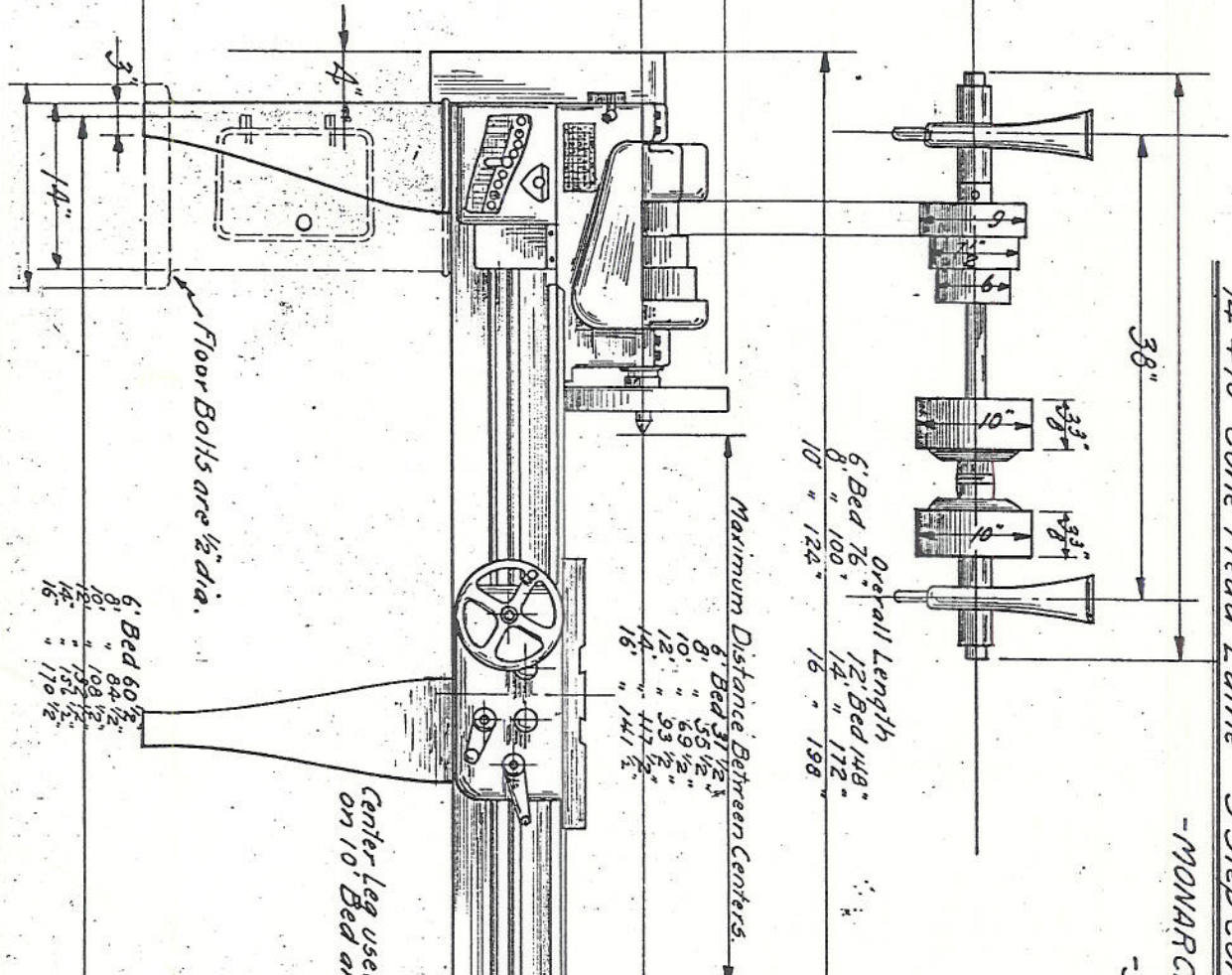

14" x 16" Cone Head Lathe 3-Step Cor
 -MONARC-

14 & 16 GEARED HEAD
THE MONARCH

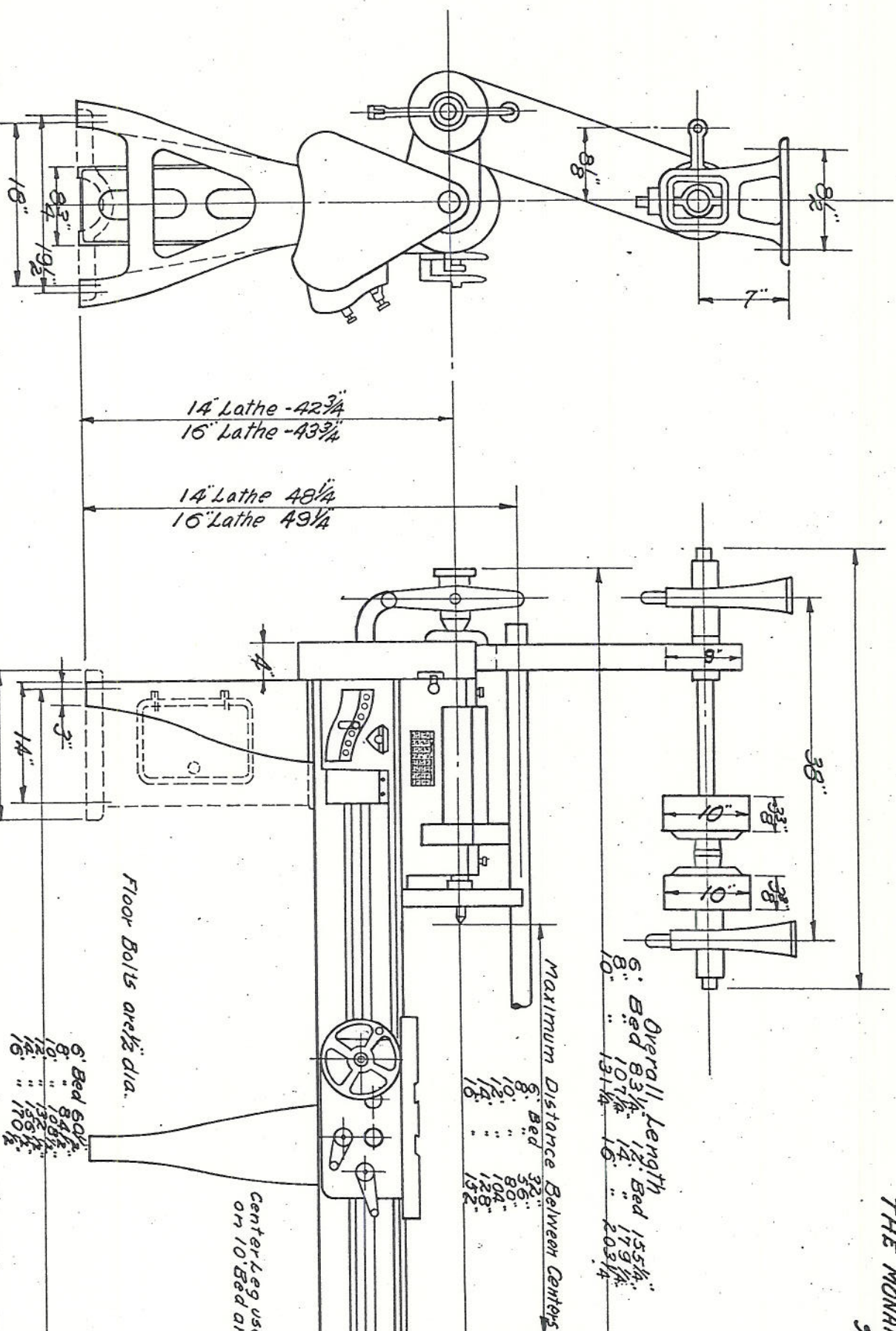

6" Bed 54 1/4"

8"	58 1/4"
10"	62 1/4"
12"	66 1/4"
14"	70 1/4"
16"	74 1/4"

14" x 16" MOTOR DRIVE.

OUTLINE.

THE MONARCH MACHINE TOOL CO.
SIDNEY, OHIO.

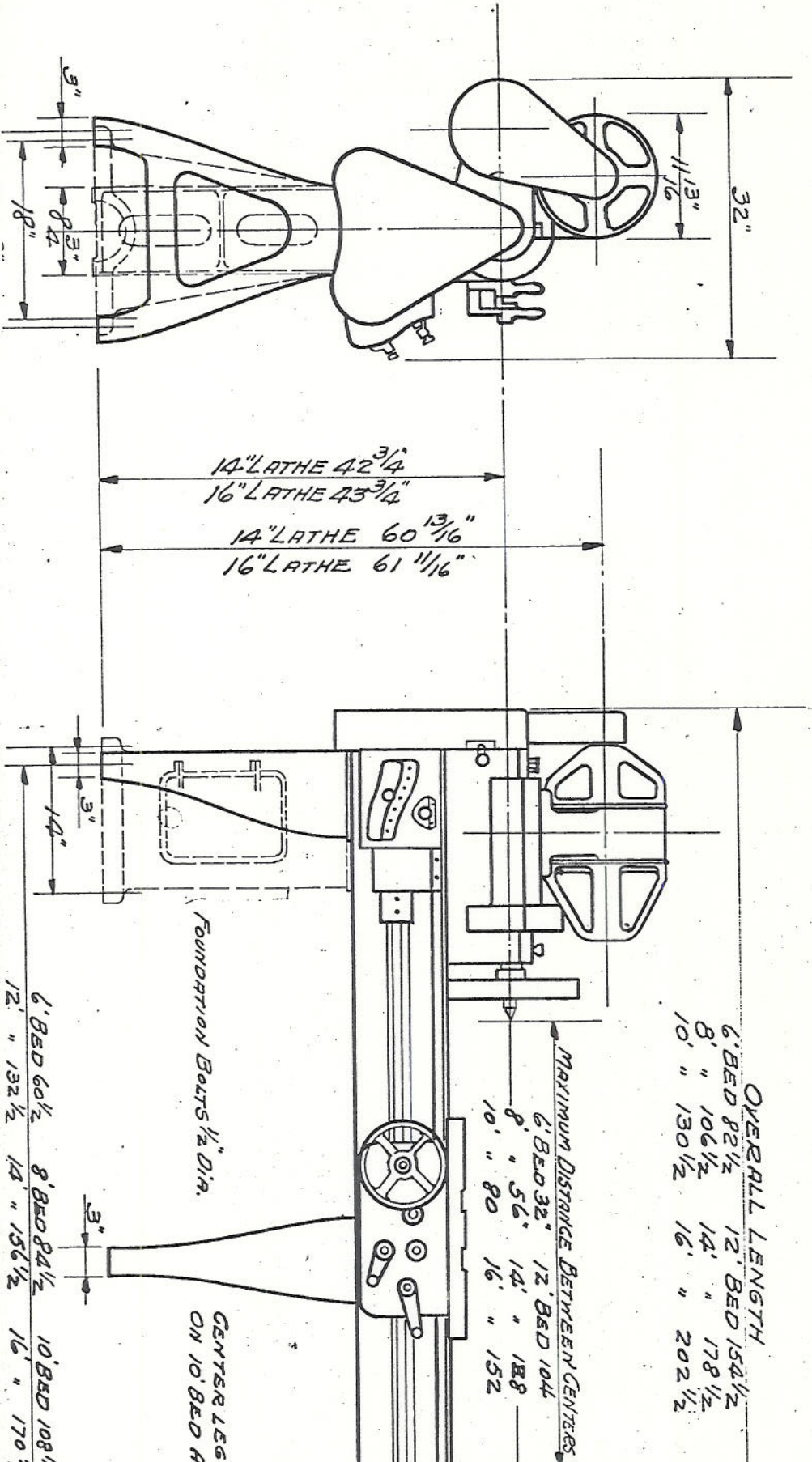

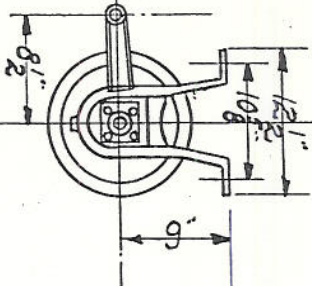
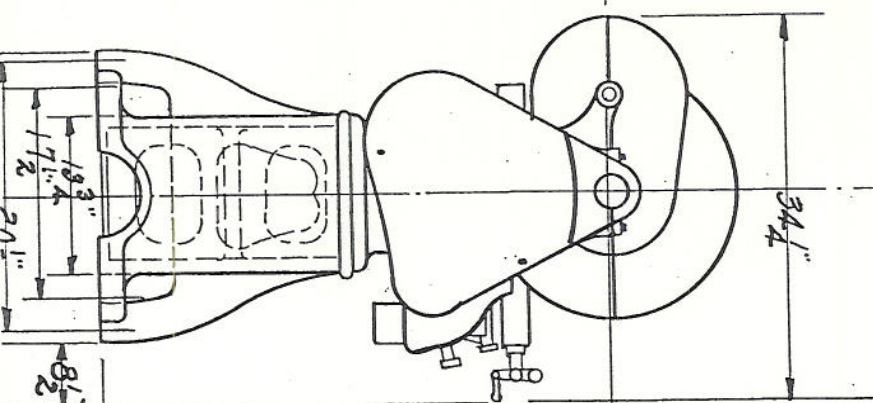

17" LATHE	50 9/16
18" "	51 3/4
20" "	53 3/4
17" LATHE	42 1/16
18" "	42 3/4
20" "	43 3/4

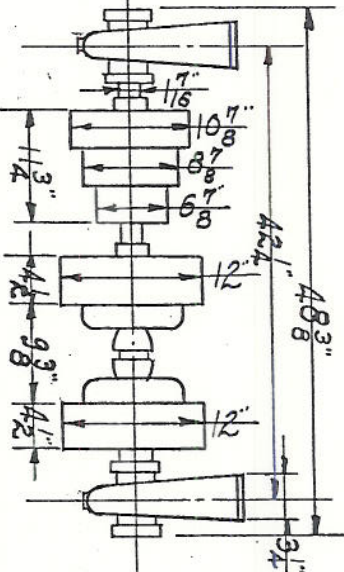

6' BED	5'-11"	14' BED	14'-11"
8' "	8'-11"	16' "	15'-11"
10' "	10'-11"	18' "	18'-11"

17-18-20" CONE HEAD LATH
THE MONARCH MACHINE TOOL C
SIDNEY, OHIO

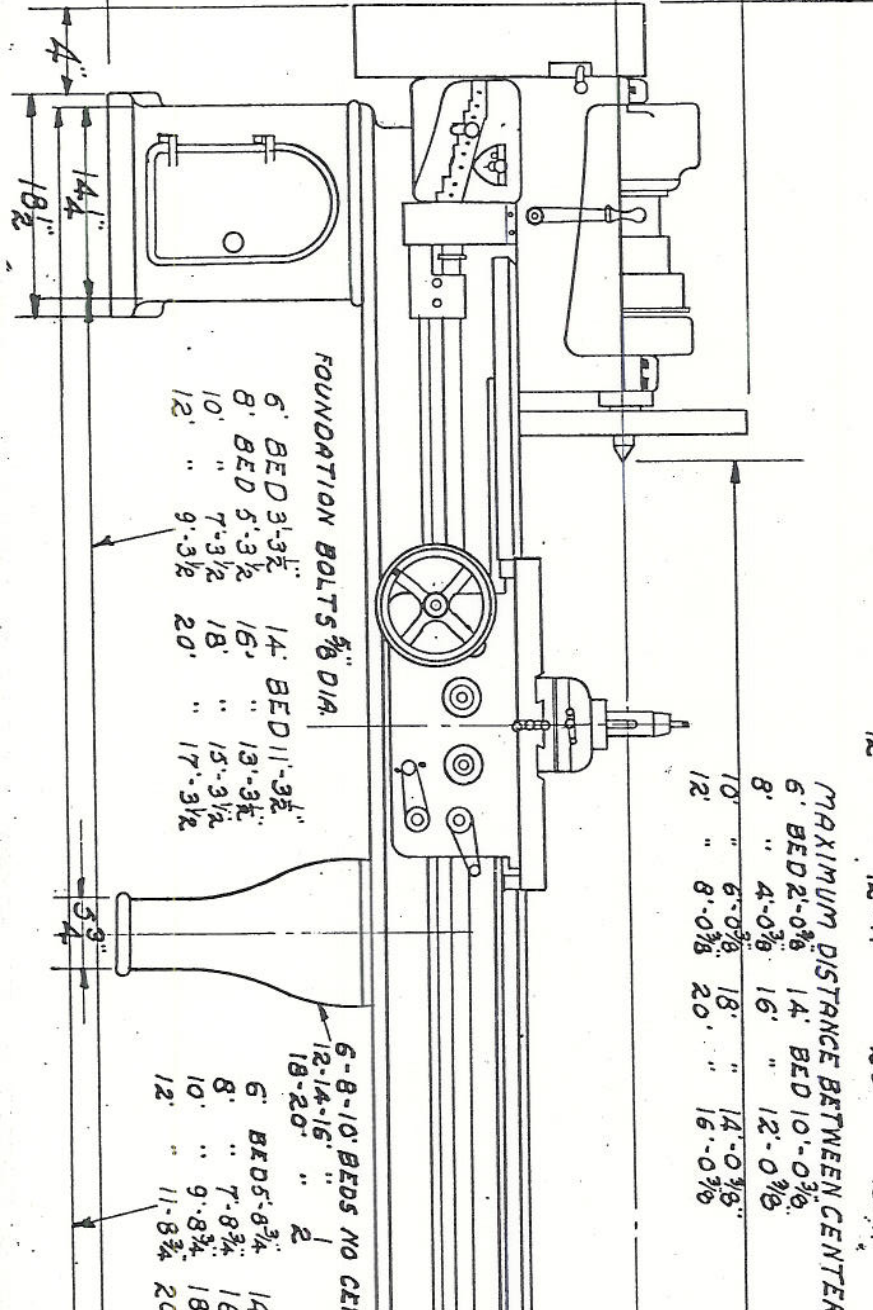

6' BED	2'-0 3/8	14' BED	10'-0 3/8
8' "	4'-0 3/8	16' "	12'-0 3/8
10' "	6'-0 3/8	18' "	14'-0 3/8
12' "	8'-0 3/8	20' "	16'-0 3/8

FOUNDATION BOLTS 5/8" DIA.

6' BED	3'-3 1/2"	14' BED	11'-3 1/2"
8' BED	5'-3 1/2"	16' "	13'-3 1/2"
10' "	7'-3 1/2"	18' "	15'-3 1/2"
12' "	9'-3 1/2"	20' "	17'-3 1/2"

6-8-10' BEDS NO CEI

6' BED	5'-8 3/4"	14'	14'
8' "	7'-8 3/4"	16'	16'
10' "	9'-8 3/4"	18'	18'
12' "	11'-8 3/4"	20'	20'

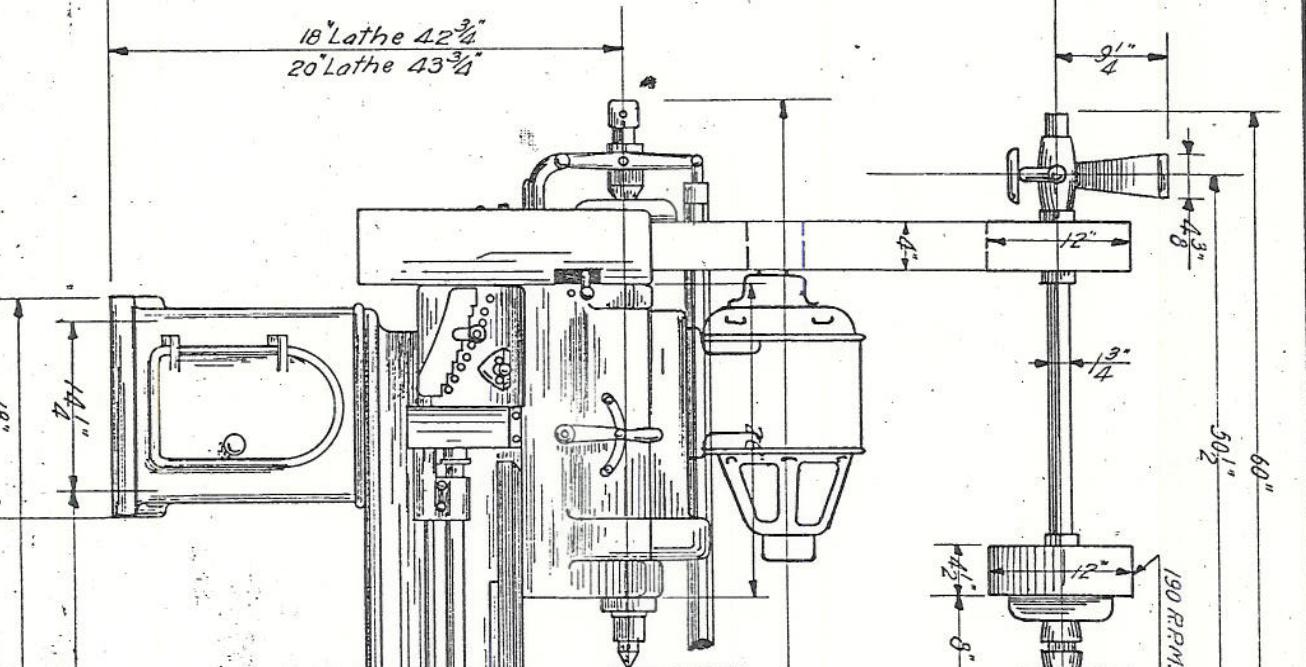
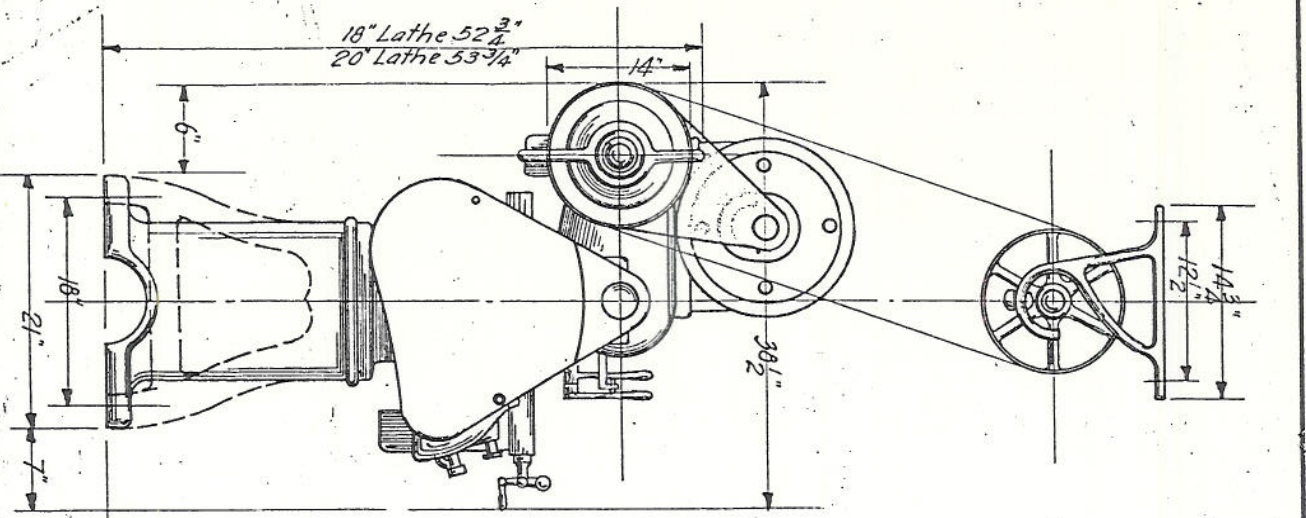

6' Bed	39 1/4"
8 "	63 3/4"
10 "	87 1/2"
12 "	111 1/2"
14 "	135 1/2"
16 "	159 1/2"

6' Bed	30 1/4"
8 "	118 1/2"
10 "	142 1/2"
12 "	166 1/2"
14 "	190 1/2"

Maximum Distance Between Centers

6' Bed	93"
8 "	117"
10 "	141"
12 "	165"
14 "	189"
16 "	213"

6' Bed	24 3/8"
8 "	48 3/8"
10 "	72 3/8"
12 "	96 3/8"
14 "	120 3/8"
16 "	144 3/8"

- MONARCH - MACHINERY
- SIDNEY
Scale

- 18" & 20" GEARED HEAD LATHE

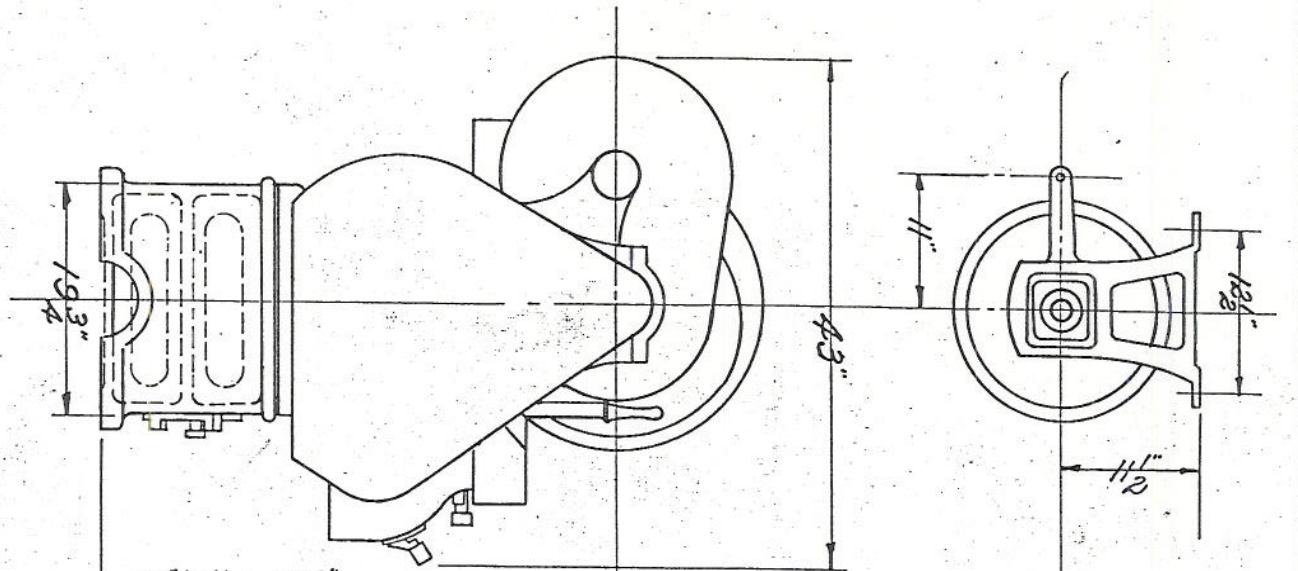

24" Lathe 55"
 26" " 56 1/8"
 28" " 59 1/4"
 30" " 60 3/8"

24" Lathe 43"
 26" " 44 1/8"
 28" " 45 1/4"
 30" " 46 3/8"

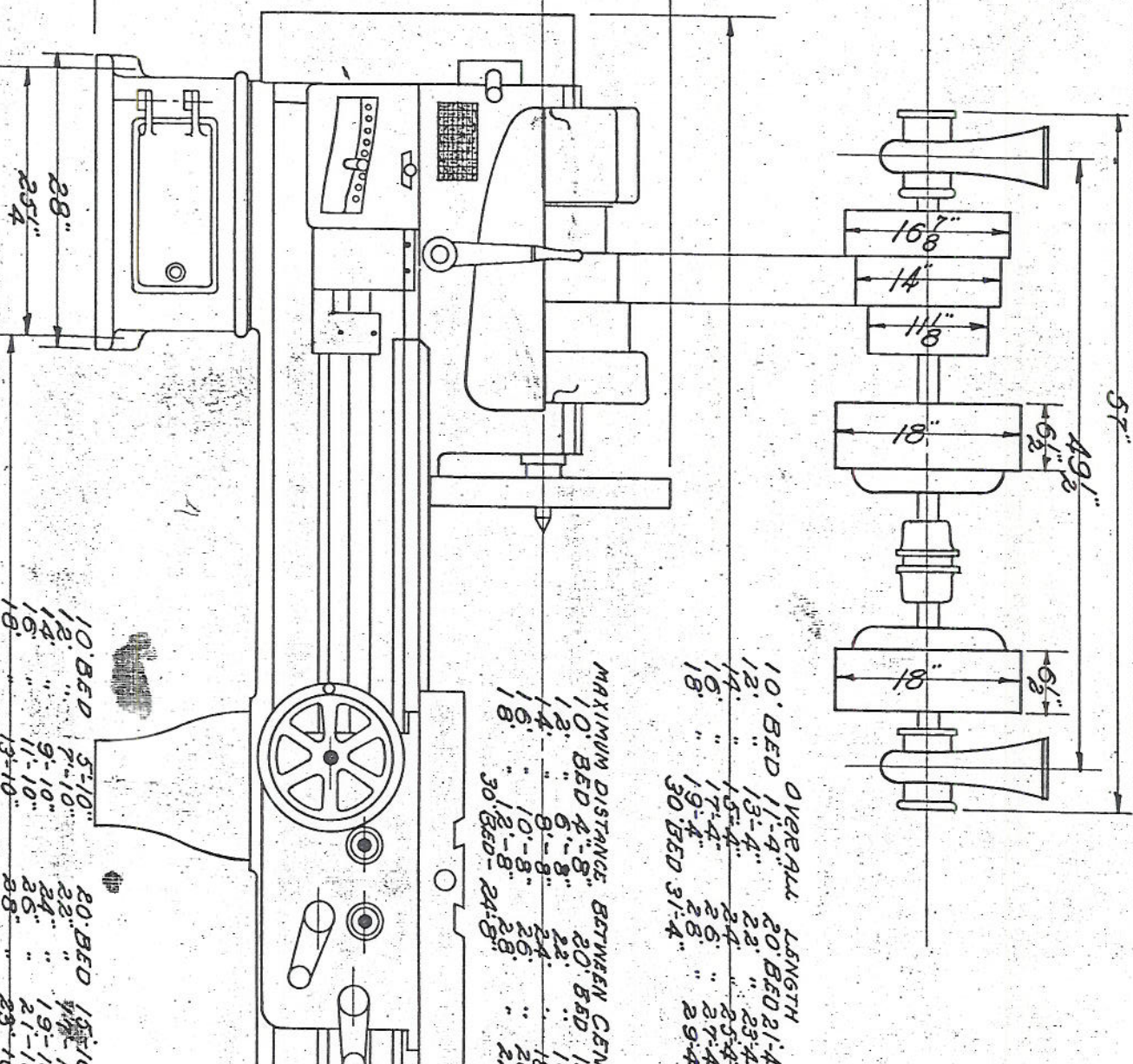

Overall Length
 10' BED 11'-4" 20' BED 21'-4"
 12" " 13'-4" 22" " 23'-4"
 14" " 15'-4" 24" " 25'-4"
 16" " 17'-4" 26" " 27'-4"
 18" " 19'-4" 28" " 29'-4"
 30' BED 31'-4" 29'-4"

MAXIMUM DISTANCE BETWEEN CEN
 10' BED 4'-8" 20' BED 11'-4"
 12" " 5'-8" 22" " 12'-4"
 14" " 6'-8" 24" " 13'-4"
 16" " 8'-8" 26" " 15'-4"
 18" " 10'-8" 28" " 17'-4"
 30' BED 24'-8" 29'-4"

10' BED 5'-10" 20' BED 11'-4"
 12" " 7'-10" 22" " 13'-4"
 14" " 9'-10" 24" " 15'-4"
 16" " 11'-10" 26" " 17'-4"
 18" " 13'-10" 28" " 19'-4"
 19" " 15'-10" 29" " 21'-4"

24"-26"-28"-30" MOTOR DRIVE

OUTLINE

THE MONARCH MACHINE TOOL CO.
SIDNEY OHIO.

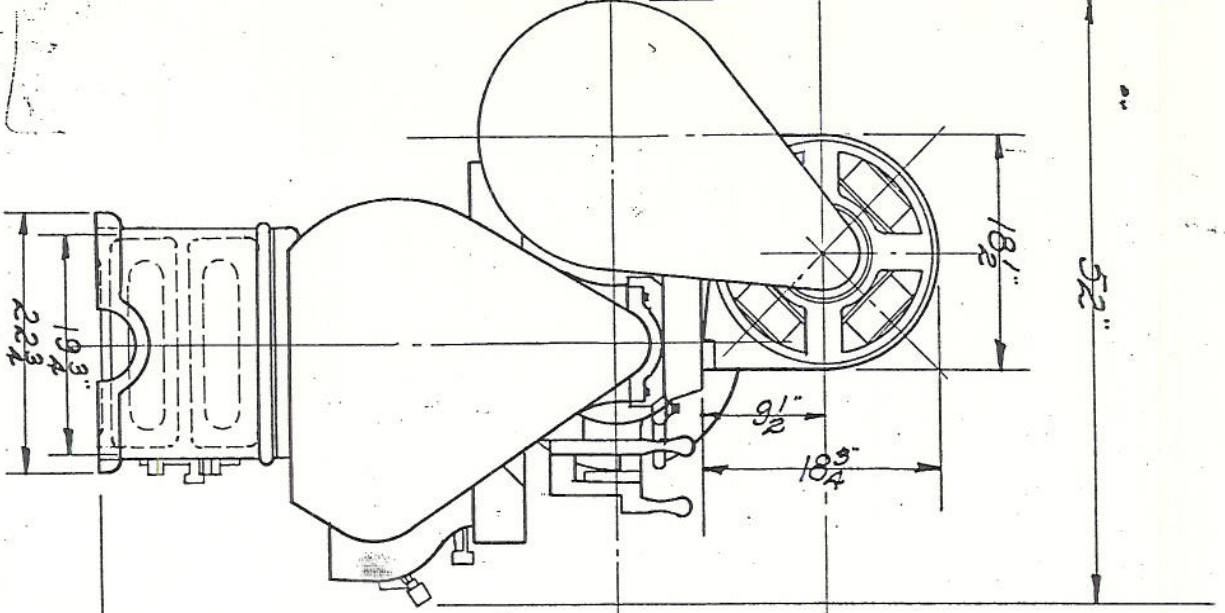

24" LATHE	-	69 1/8"
26"	"	70 1/4"
28"	"	71 3/8"
30"	"	72 1/2"
24" LATHE		43"
26"	"	44 1/8"
28"	"	45 1/4"
30"	"	46 3/8"

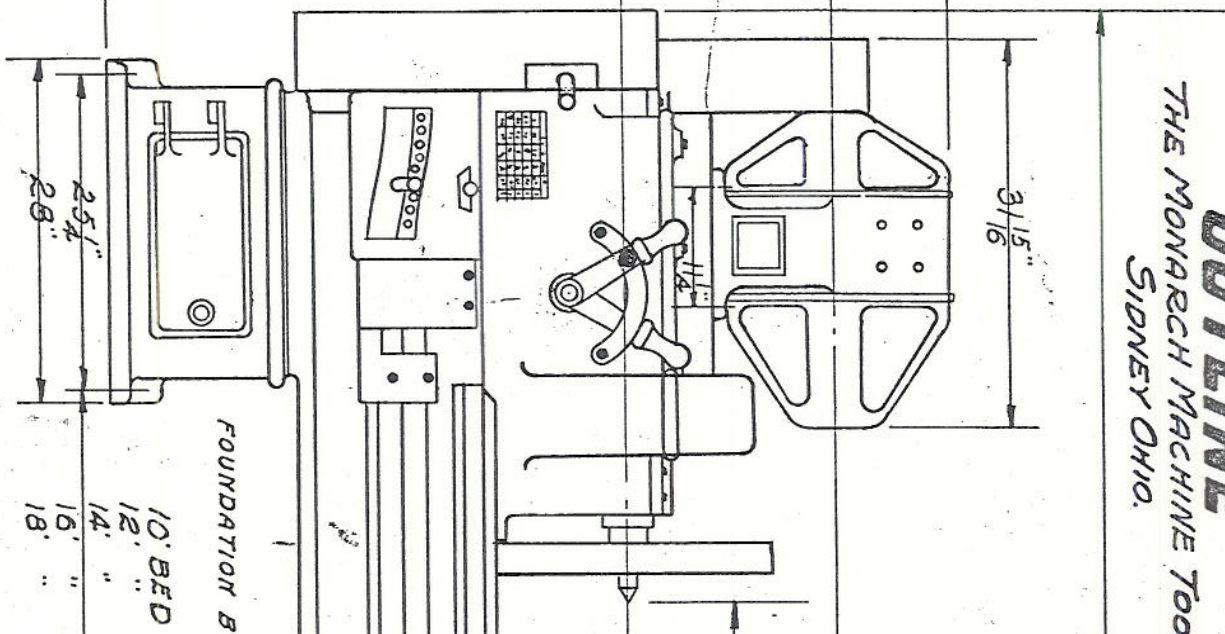

FOUNDATION BOLTS 3/4" DIA.	10' BED	5'-10"	11'-10"	13'-10"	9"
16"	12"	14"	16"	18"	26"
10' BED	11'-4"	13'-4"	15'-4"	17'-4"	28"
12"	"	"	"	"	28"
14"	"	"	"	"	24"
16"	"	"	"	"	26"
18"	"	"	"	"	28"
30' BED	9'-1"	11'-4"	13'-4"	15'-4"	28"
10' BED	4'-8"	6'-8"	8'-8"	10'-8"	26"
12"	"	"	"	"	22 1/2"
14"	"	"	"	"	24"
16"	"	"	"	"	26"
18"	"	"	"	"	28"
30' BED	2'-8"	4'-8"	6'-8"	8'-8"	26"
10'-12'-14' BED	16'-18'-20'"	22'-24'"	26'-28'-30'"	20' BED	26"
16'-18'-20'"	22'-24'"	26'-28'-30'"	20' BED	28"	28"
26'-28'-30'"	20' BED	26"	28"	30"	30"

OVER ALL LENGTH

10' BED	11'-4"	20' BED	28"
12"	"	"	"
14"	"	"	"
16"	"	"	"
18"	"	"	"
30' BED	9'-1"	11'-4"	28"

MAXIMUM DISTANCE BETW.

10' BED	4'-8"	20' BED	26"
12"	"	"	"
14"	"	"	"
16"	"	"	"
18"	"	"	"
30' BED	2'-8"	24'-8"	26"

~ 14" x 16" MOTOR DRIVEN PORTABLE LATHE. ~

~ THE MORGAN MACHINE TOOL CO. ~

~ SIDNEY OHIO. ~

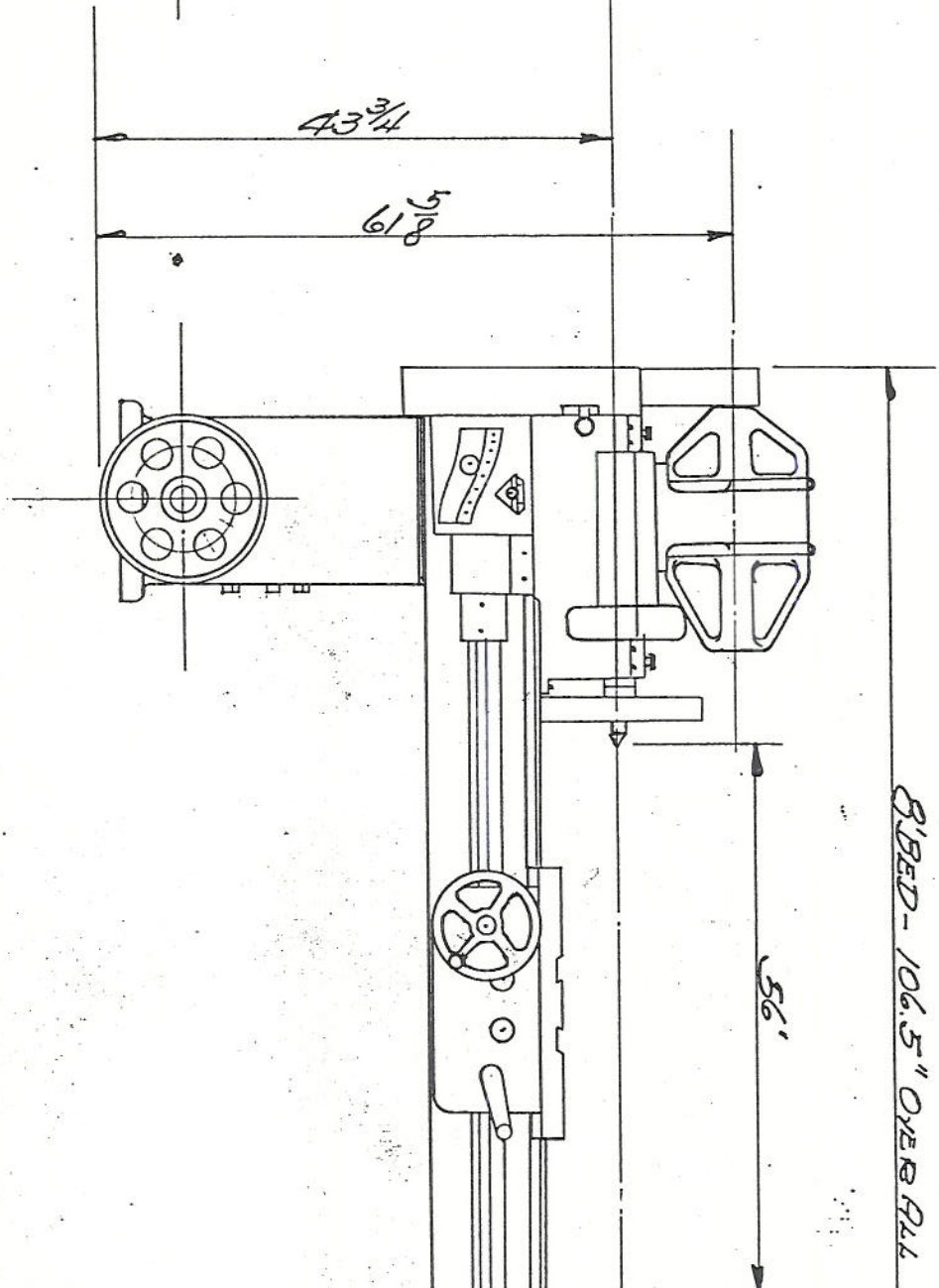
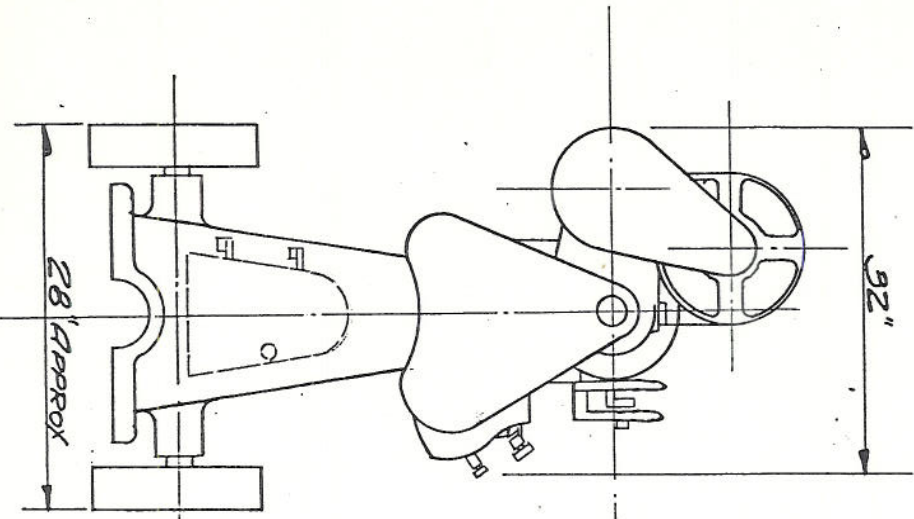

8 BED - 106.5" OVER ALL

DIAMETER OF RECESS-4-JAW INDEPENDENT CHUCKS.

NAME	5 IN.	4 IN.	3 IN.	6 IN.	8 IN.	9 IN.	10 IN.	12 IN.	14 IN.	16 IN.	18 IN.	20 IN.	24 IN.
SKINNER	5"	5"	5"	5"	5"	5"	6"	6 ³ / ₈ "	7 ³ / ₄ "	8 ³ / ₄ "	10"	11"	13"
HORTON	5 ¹ / ₁₆ "	4 ³ / ₄ "	5 ¹ / ₁₆ "	4 ³ / ₄ "	5 ¹ / ₁₆ "	6"	6 ¹ / ₁₆ "	6 ¹ / ₁₆ "	6 ¹ / ₁₆ "	7 ¹³ / ₁₆ "	7 ¹³ / ₁₆ "	7 ¹³ / ₁₆ "	9 ¹ / ₂ "
CUSHMAN	5 ⁵ / ₈ "	4 ³ / ₄ "	4 ³ / ₄ "	4 ²⁹ / ₃₂ "	5 ⁵ / ₈ "	5 ⁵ / ₈ "	6 ¹ / ₁₆ "	6 ⁵ / ₁₆ "	6 ⁵ / ₁₆ "	7 ¹³ / ₁₆ "	8 ⁵ / ₁₆ "	8 ⁵ / ₁₆ "	8 ⁵ / ₁₆ "
WHITON	3 ²⁵ / ₃₂ "			4 ²⁹ / ₃₂ "	5"	5"	4 ²⁹ / ₃₂ "	6 ⁵ / ₁₆ "	6 ⁵ / ₁₆ "	7"	8"	8 ⁵ / ₁₆ "	8 ⁵ / ₁₆ "
UNION	5"	5"	5"	5"	5"	5"	5"	7"	8"	8"	10"	10"	12"
SWEETLAND	5 ⁵ / ₈ "	4 ³ / ₄ "	5 ⁵ / ₈ "	5 ⁵ / ₈ "	5 ⁵ / ₈ "	5 ⁵ / ₈ "	6 ¹ / ₁₆ "	6 ¹ / ₁₆ "	7 ¹³ / ₁₆ "	7 ¹³ / ₁₆ "	9 ¹ / ₂ "	9 ¹ / ₂ "	11"

DIAMETER OF RECESS-3-JAW UNIVERSAL CHUCKS.

NAME	6 IN.	7 1/2 IN.	9 IN.	10 1/2 IN.	12 IN.	15 IN.	18 IN.	21 IN.	24 IN.
SKINNER	3 ¹ / ₂ "	4 ¹ / ₂ "	5"	7"	6 ³ / ₈ "	7"	8"	10"	12"
HORTON	4 ³ / ₄ "	6"	7"	7"	7"	8"	10"	11"	12"
CUSHMAN	4 ³ / ₄ "	4 ³ / ₄ "	5 ⁵ / ₈ "	5 ⁵ / ₈ "	7"	7"	9 ¹ / ₂ "	9 ¹ / ₂ "	
WHITON	5 ⁵ / ₈ "	7"	8 ⁹ / ₁₆ "	9 ¹³ / ₁₆ "	7"	8 ⁵ / ₁₆ "	9 ¹³ / ₁₆ "	10 ¹ / ₂ "	13 ¹ / ₂ "
UNION	3 ¹ / ₁₆ "		5 ¹ / ₃₂ "		6 ³ / ₈ "	7 ¹ / ₁₆ "	8	9 ²¹ / ₃₂ "	10"
SWEETLAND	3 ⁹ / ₁₆ "		5"		5 ⁷ / ₈ "	5 ⁷ / ₈ "	9"	9"	9"

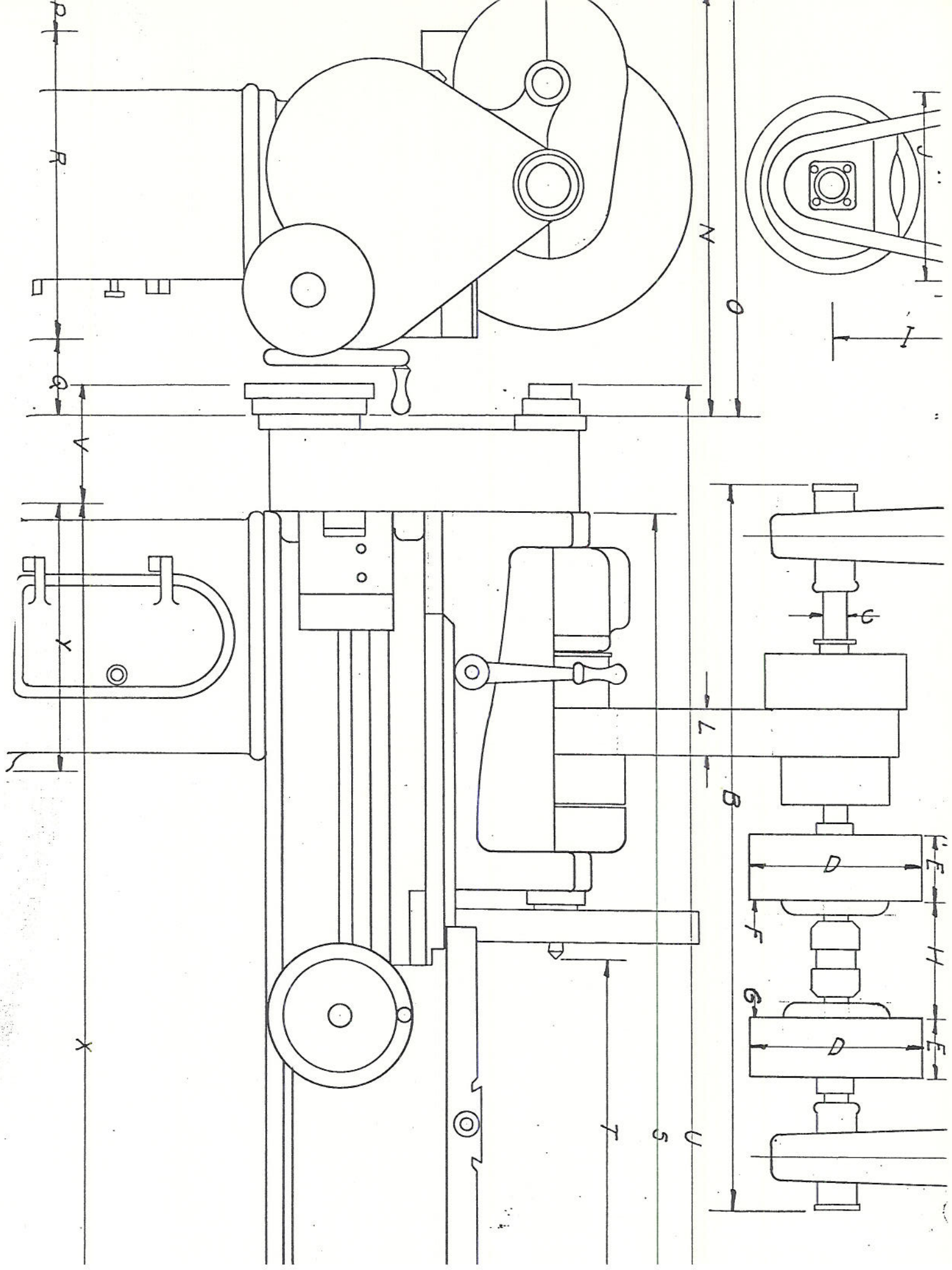

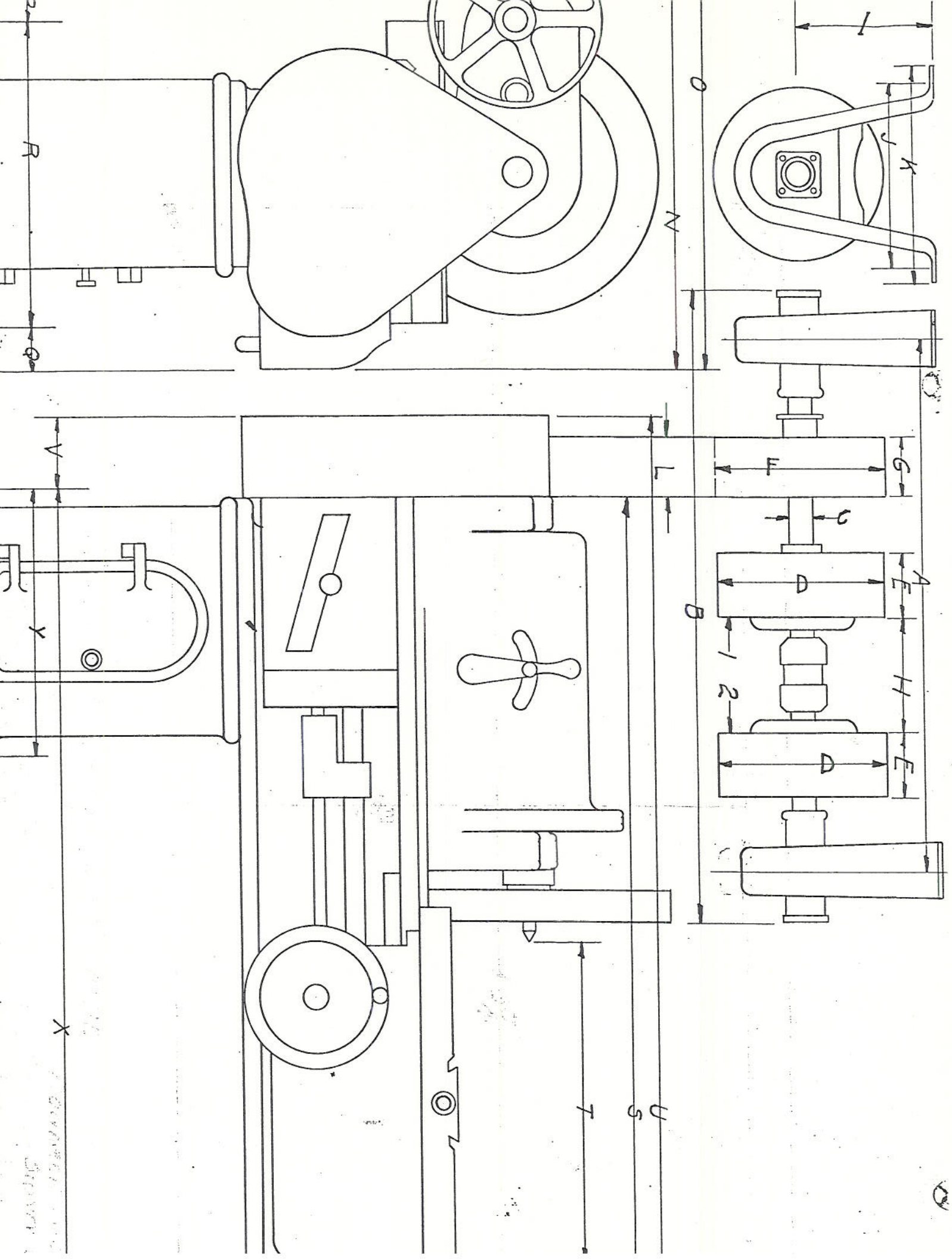

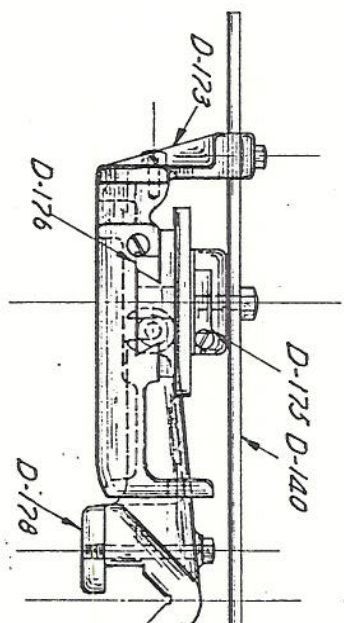
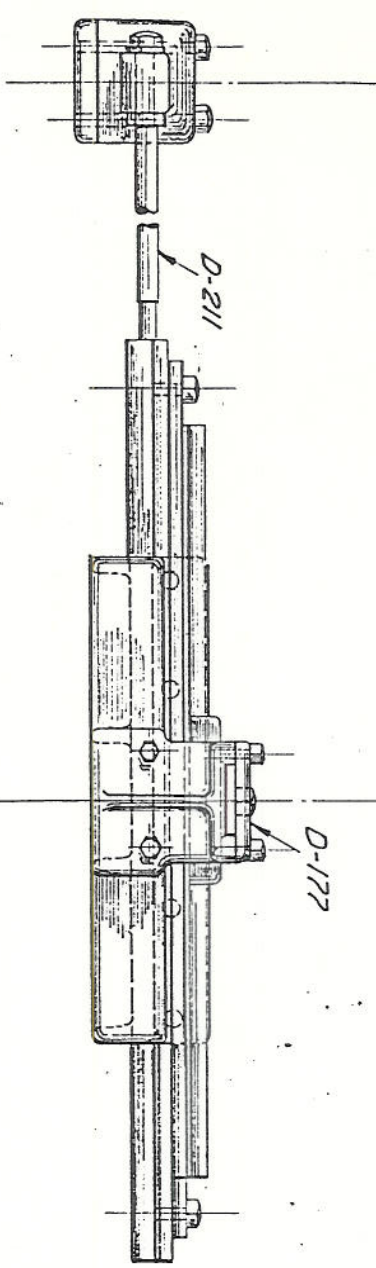
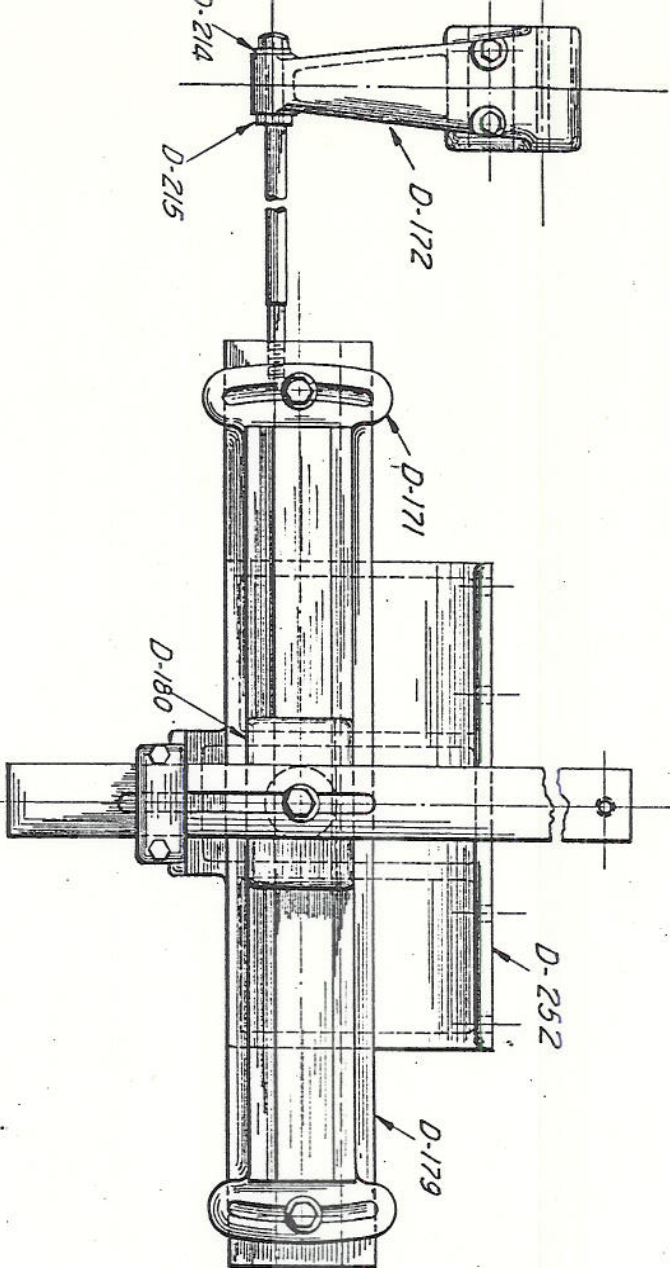

Taper Attachment used on 24" 26"

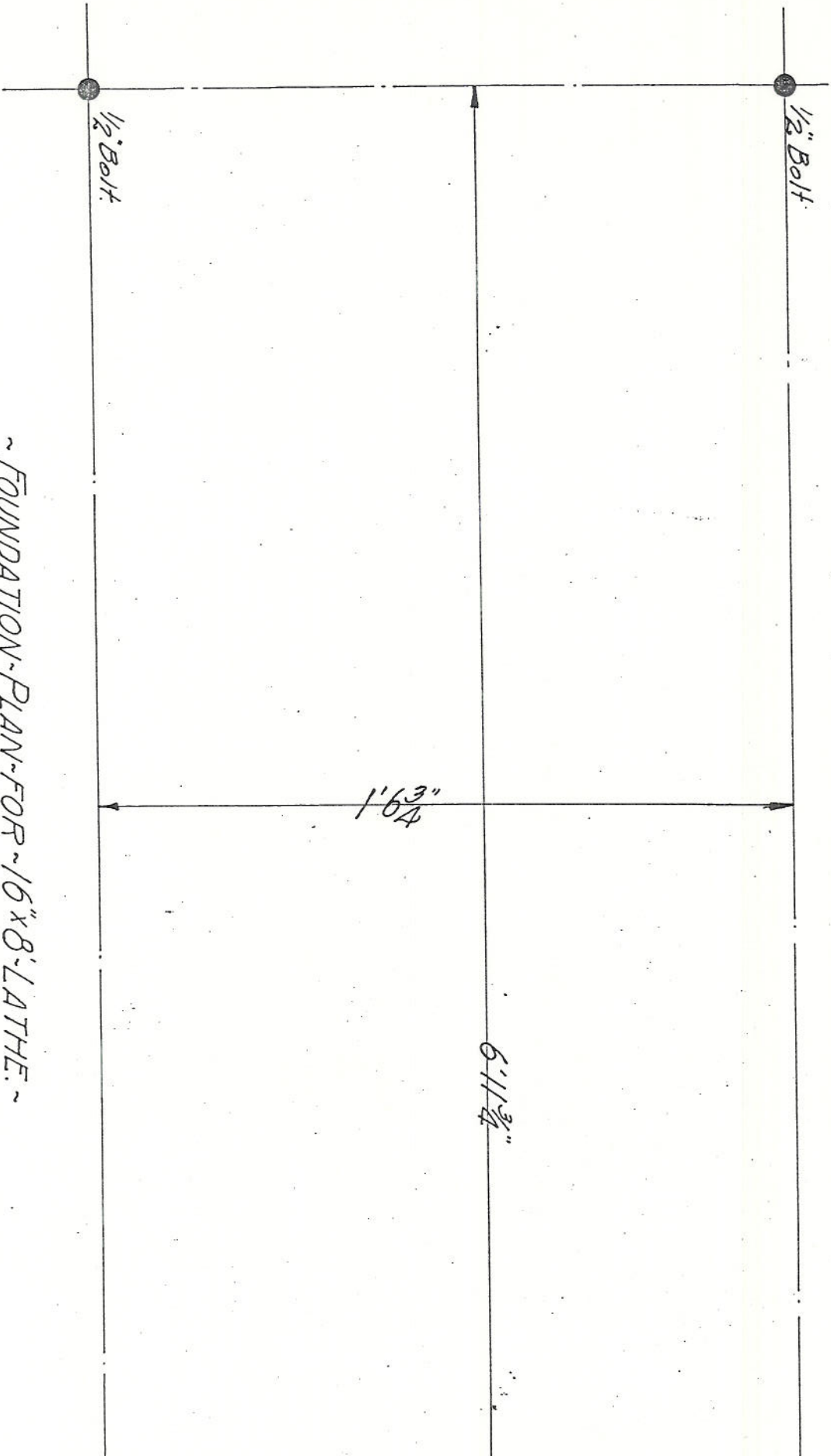

Monarch Machin
Sidney, O.

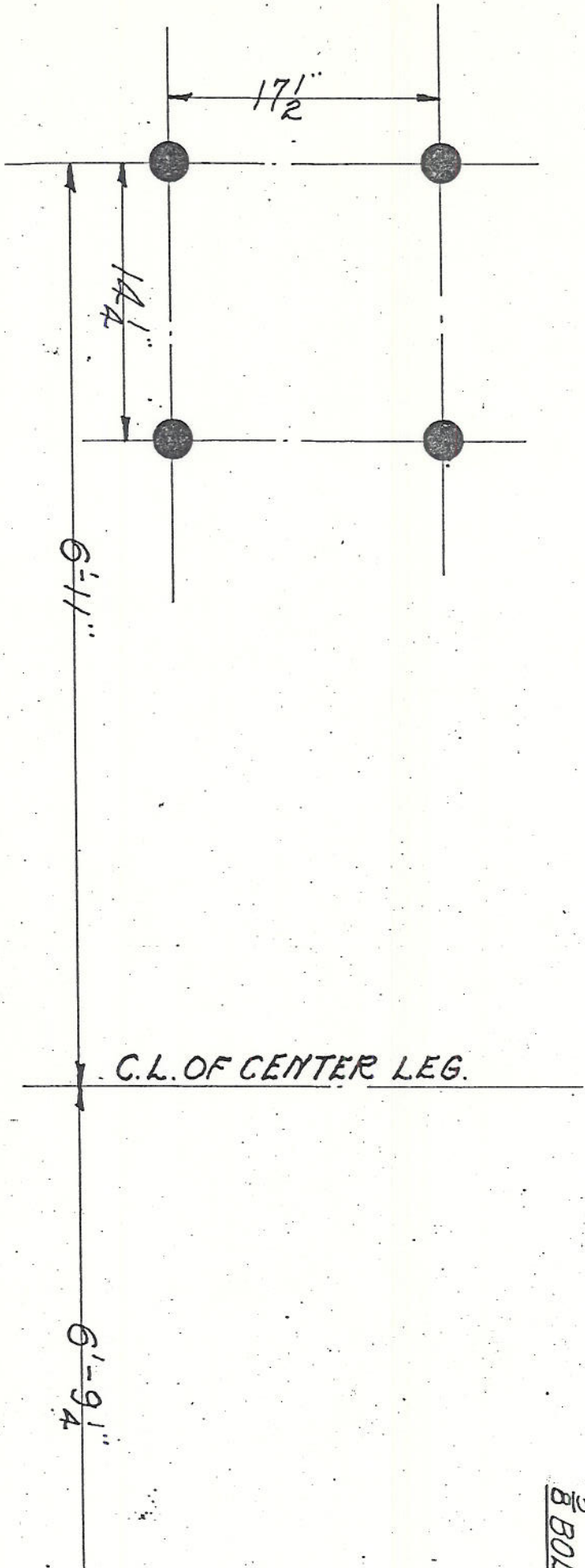

THE MONARCH MACHINE TOOL CO.
 SIDNEY, OHIO.
 FOUNDATION PLAN FOR 20" X 14" LATHE.

5"
 8 BOL

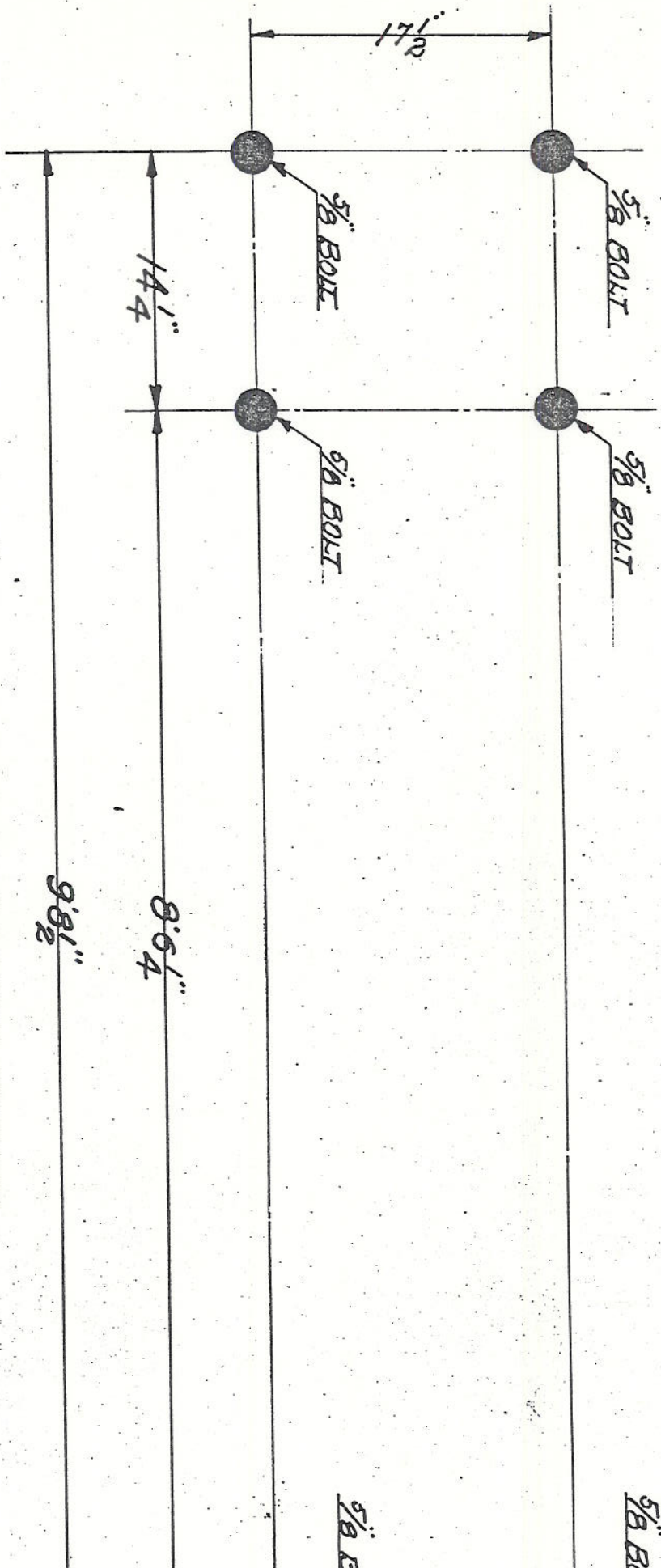

THE MONARCH MACHINE TOOL CO.
 SIDNEY OHIO.
 FOUNDATION PLAN FOR 18"x10" LATHE

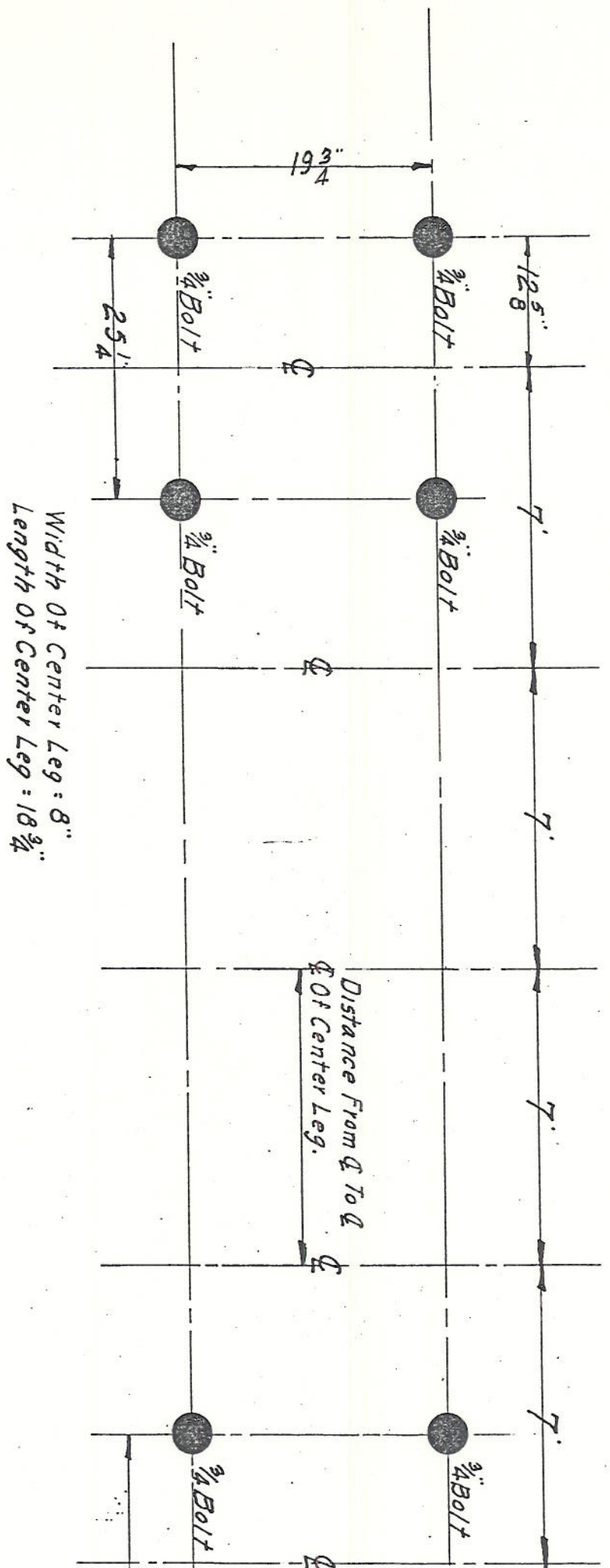

THE MONARCH MACHINE TOOL CO.
 SIDNEY, OHIO.
 FOUNDATION PLAN FOR 30" x 30" LATHE

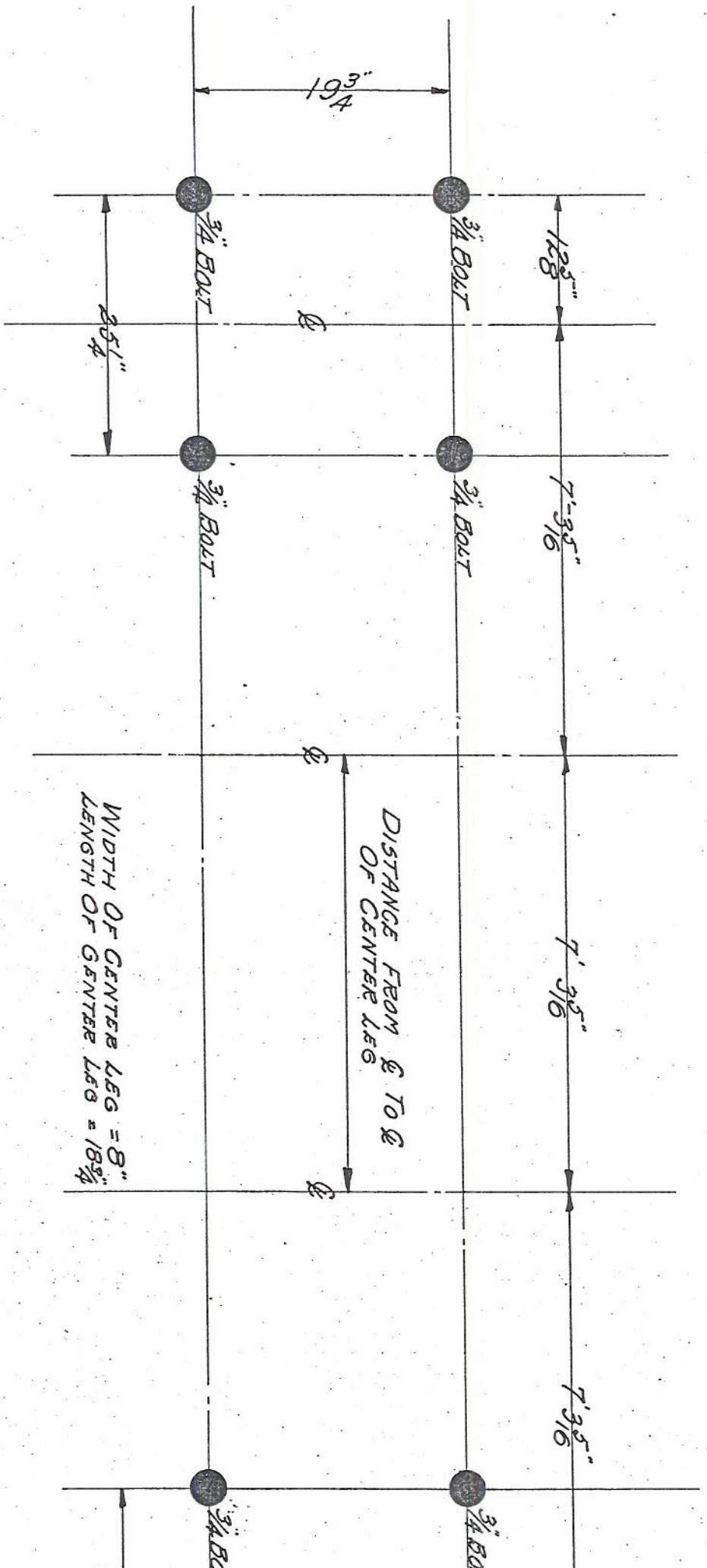

THE MONARCH MACHINE TOOL CO.
 SIDNEY, OHIO.
 FOUNDATION PLAN FOR 30" X 24" LATHE

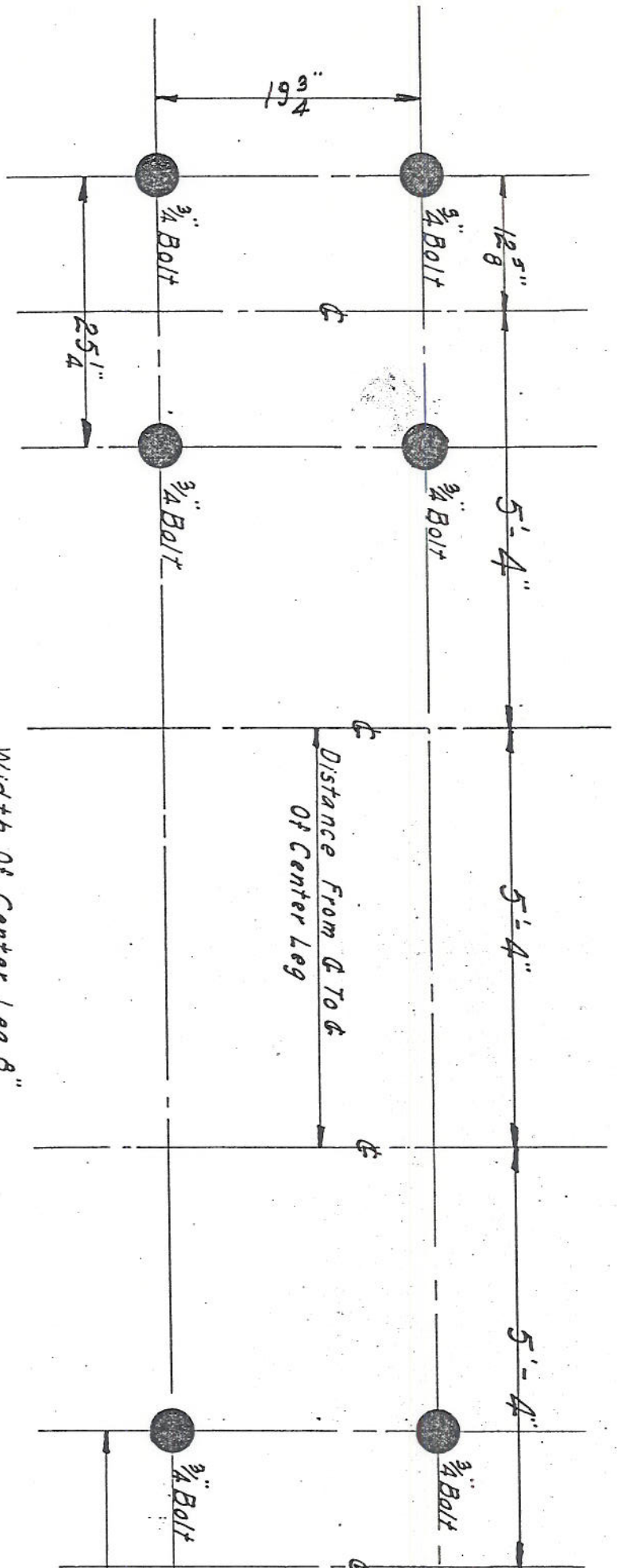

Width Of Center Leg 8"
 Length Of Center Leg 18 $\frac{3}{4}$ "

THE MONARCH MACHINE TOOL CO.
 SIDNEY, OHIO.
 FOUNDATION PLAN FOR 30"x18" LATHE.