



SPX Corporation  
 655 Eisenhower Drive  
 Owatonna, MN 55060-0995 USA  
 Phone: (507) 455-7000  
 Tech. Serv.: (800) 533-6127  
 Fax: (800) 955-8329  
 Order Entry: (800) 533-6127  
 Fax: (800) 283-8665  
 International Sales: (507) 455-7223  
 Fax: (507) 455-7063

Form No. 100501

Parts List for:

1813  
 1814

ACTP-10615  
 JT01709  
 OEM1405

# Floor Crane Assembly

Max. Capacity: 6,000 lbs.

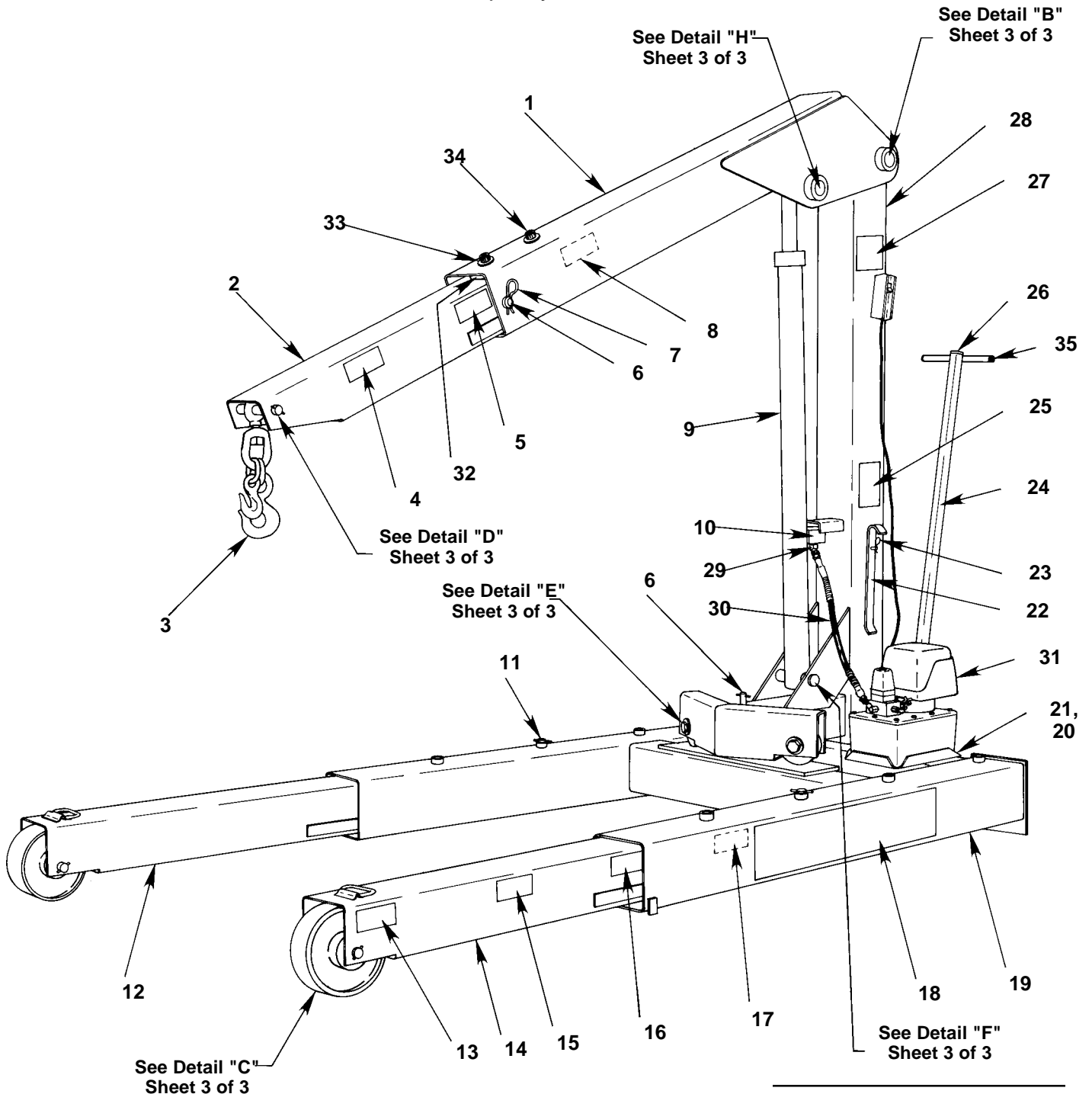

Sheet No.	1 of 3
Issue Date:	Rev. 7-1-97

Item No.	Part No.	No. Req'd	Description
1	<b>61020</b>	1	Boom Weldment <i>(includes items in Detail "H")</i>
2	<b>51975</b>	1	Boom Extension
3	<b>51969</b>	1	Chain Swivel
4	<b>303191</b>	1	Warning Decal
5	<b>303192</b>	1	Warning Decal
6	<b>303232</b>	2	Pin
7	<b>17072</b>	2	Hair Pin
8	<b>303190</b>	1	Warning Decal
9	<b>51987</b>	1	Cylinder Assembly <i>(see Sheet 2 of 3)</i>
10	<b>28824</b>	1	Flow Control Valve
11	<b>303233</b>	2	Pin
12	<b>51980</b>	1	Right Leg
13	<b>303189</b>	1	Warning Decal
14	<b>51977</b>	1	Left Leg
15	<b>303188</b>	1	Warning Decal
16	<b>303187</b>	1	Warning Decal
17	<b>303186</b>	1	Warning Decal
18	<b>45158</b>	2	Decal
19	<b>61017</b>	1	Base Weldment
20	<b>52683-WH2</b>	1	Reservoir Mount <i>(for 1814)</i>
21	<b>212380</b>	4	Slotted Screw <i>(for 1814)</i>
22	<b>44825</b>	1	Leg Lift Bar
23	<b>207649</b>	1	Hair Pin
24	<b>53422</b>	1	Dolly <i>(see Sheet 2 of 3 for detail)</i>
25	<b>303185</b>	1	Instruction Decal
26	<b>207655</b>	1	Tube Cap
27	<b>303833</b>	2	Trade Name Decal <i>(for 1813 &amp; 1814)</i>
28	<b>61019</b>	1	Mast Weldment
29	<b>10648</b>	1	45° Swivel Elbow
30	<b>36890</b>	1	Hydraulic Hose
31	<b>61399</b>	1	Electric Hydraulic Pump <i>(see Form #101445; for 1814)</i>
	<b>61872</b>	1	Hand Pump <i>(see Form #101404; for 1813, ACTP-10615, JT01709, &amp; OEM1405)</i>
32	<b>200565</b>	1	Plate
33	<b>10586</b>	2	Washer <i>(for 1/2" bolt)</i>
34	<b>17075</b>	2	Socket Hd. Cap Screw <i>(1/2-13 UNC x 3/4" Lg.)</i>
35	<b>209550</b>	2	End Cap

**Parts Included but Not Shown**

<b>207800</b>	1	Warning decal <i>(located on back of mast weldment)</i>
<b>303234</b>	1	Pin
<b>19656</b>	1	Hex Hd. Cap Screw <i>(5/8-11 x 2-3/4" Lg.; used on end of cylinder rod)</i>
<b>309956</b>	1	Made in USA Decal

Shaded areas reflect the last revisions made to this form.

Dolly Detail

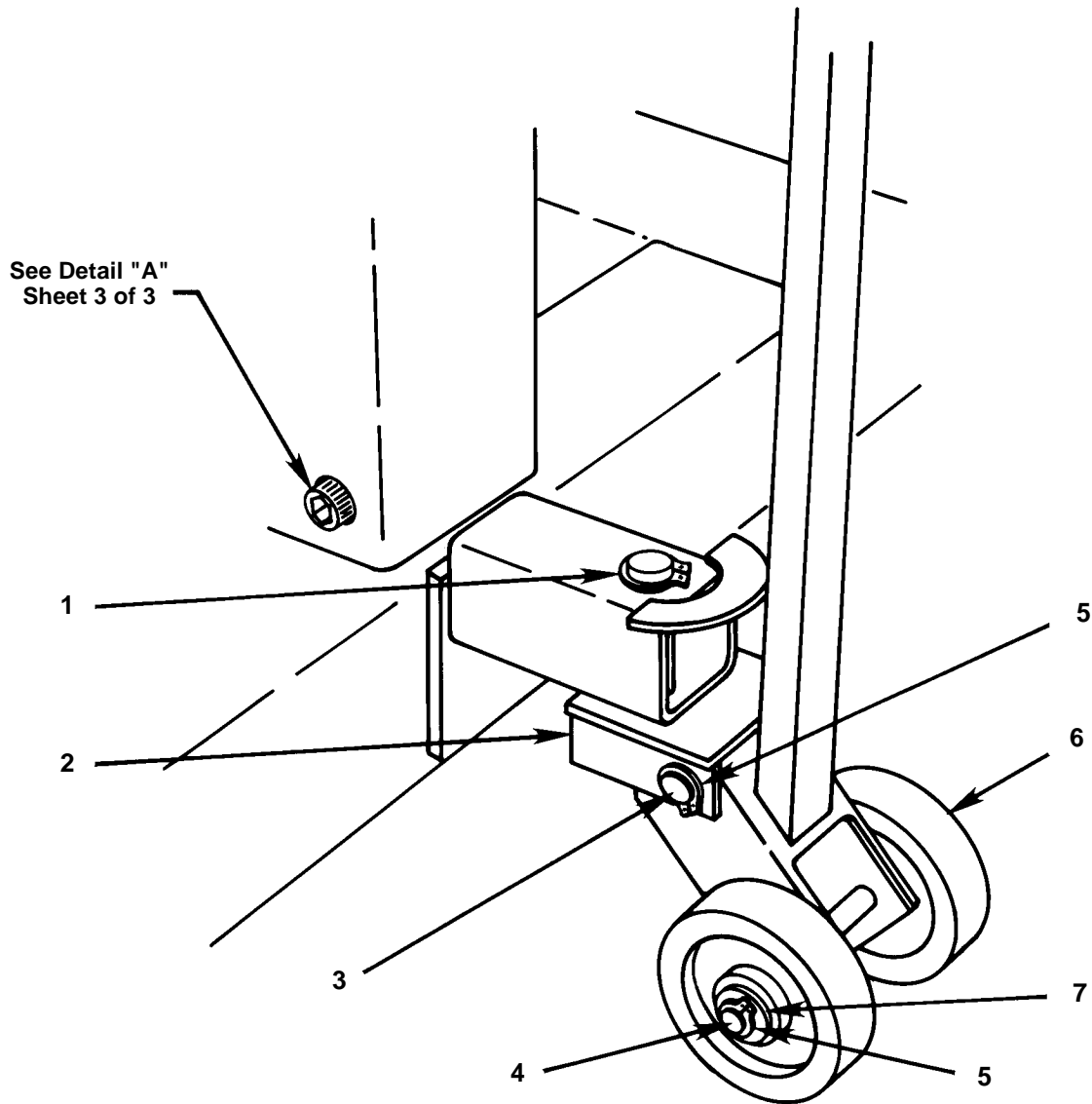

Item No.	Part No.	No. Req'd	Description
1	11998	1	Retaining Ring (for 1" shaft)
2	47762	1	Dolly Pivot Block
3	309260	1	Pin
4	309261	1	Pin
5	14855	4	Retaining Ring (for 3/4" shaft)
6	12078-1	2	Wheel (5" dia.)
7	12330	2	Washer (for 3/4" bolt)

Sheet No. 2 of 3

Issue Date: Rev. 7-1-97

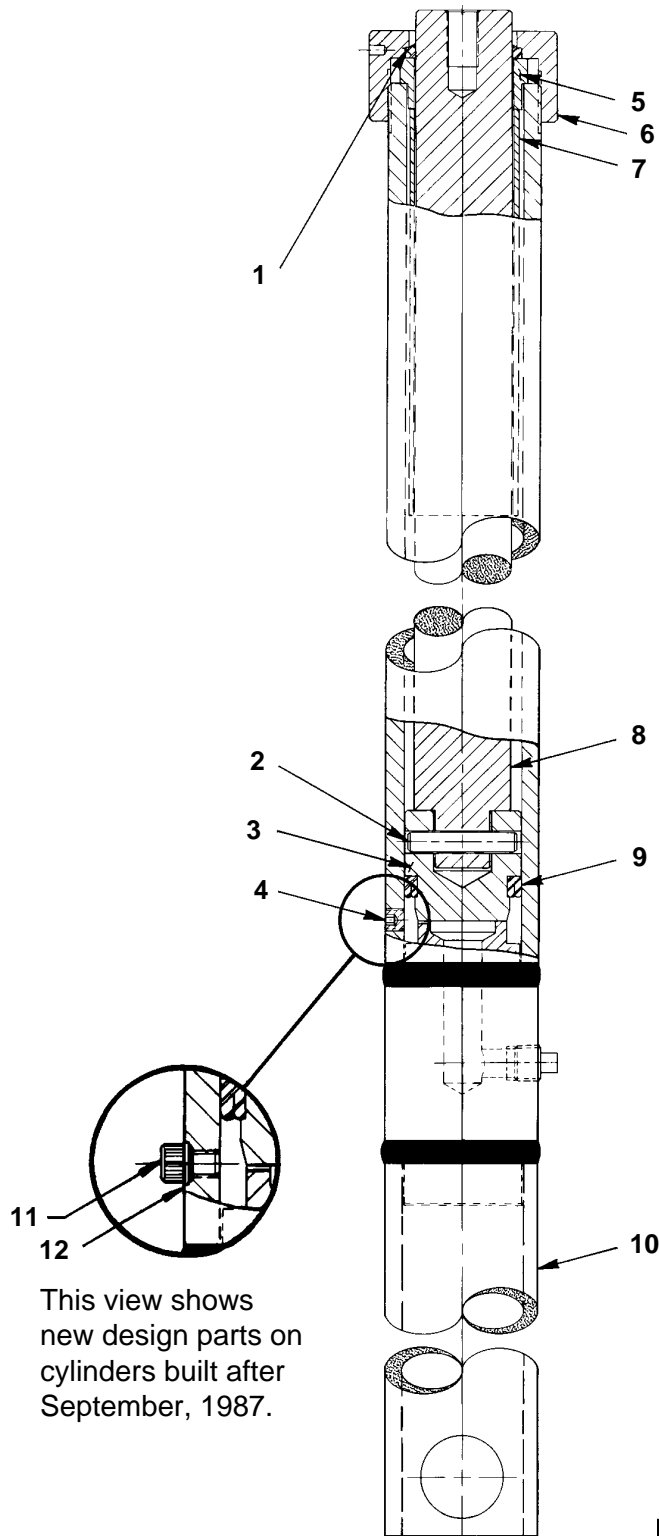

This view shows new design parts on cylinders built after September, 1987.

### Cylinder Assembly

Item No.	Part No.	No. Req'd	Description
1	207651	1	Rod Wiper
2	207636	1	Pin
3	44819	1	Piston Head
4	10427	1	Pressure Plug (1/8 NPTF; not used after 9/87)
5	207640	1	Rod Guide
6	44820	1	Collar
7	303228	1	Tube
8	44828	1	Piston Rod
9	11375	1	U-cup (Disogrin)
10	51963	1	Cylinder Body
11	10002	1	Cap Screw (1/4-20 UNC x 3/8" Lg.; torque to 90/100 in. lbs.; used after 9/87)
12	10442	1	Plain Washer (3/8 x 1/4 x 1/32; used after 9/87)

Refer to any operating instructions included with the product for detailed information about operation, testing, disassembly, reassembly, and preventive maintenance.

Items found in this parts list have been carefully tested and selected by OTC. **Therefore: Use only OTC replacement parts!**

Additional questions can be directed to the OTC Technical Services Department at 1-800-533-6127.

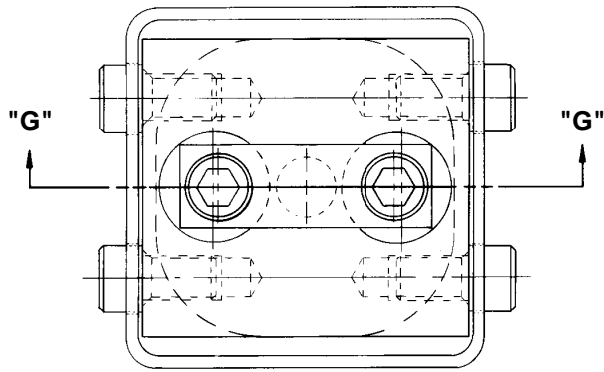

**Detail A**

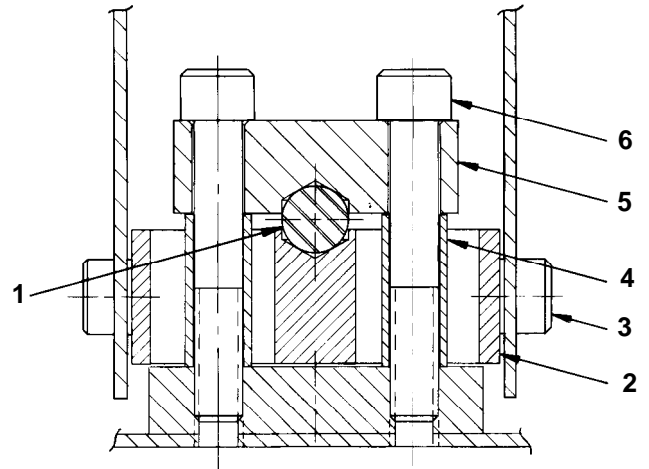

**Section G - G**

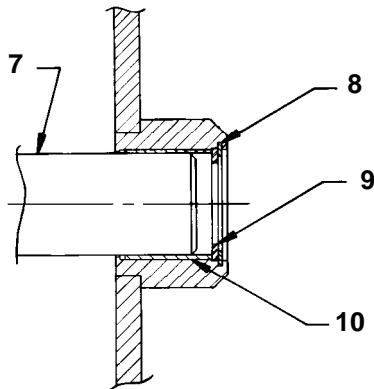

**Detail B**

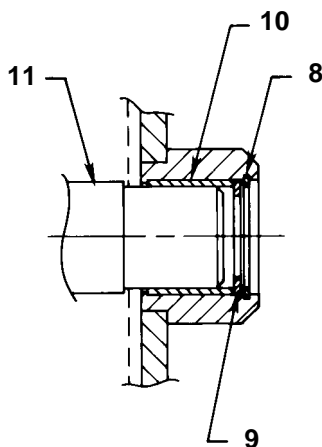

**Detail H**  
(see note)

Item No.	Part No.	No. Req'd	Description
1	<b>18954</b>	1	Metallic Ball (1" dia.)
2	<b>44818</b>	1	Block
3	<b>14397</b>	4	Socket Hd. Cap Screw (self-locking; 3/4-10 UNC x 1-1/4" Lg.; torque to 150/175 ft. lbs.)
4	<b>207642</b>	2	Tube
5	<b>303227</b>	1	Block
6	<b>207648</b>	2	Socket Hd. Cap Screw (self-locking; 3/4-10 UNC x 4-1/2" Lg.; torque to 120/125 ft. lbs.)
7	<b>303222</b>	1	Pin
8	<b>207633</b>	4	Retaining Ring (for 1.653 shaft)
9	<b>207652</b>	4	Precision Support Washer
10	<b>207653</b>	4	Sleeve Bearing
11	<b>44823</b>	1	Pin

**Note:** When replacing the sleeve bearing (10) and pin (11) shown in Detail H, remove the retaining ring (8) and support washer (9) from both sides. Drive the pin (11) out. The shoulder on the pin will drive the sleeve bearing out. Put the pin back in and drive out the sleeve bearing on the opposite side.

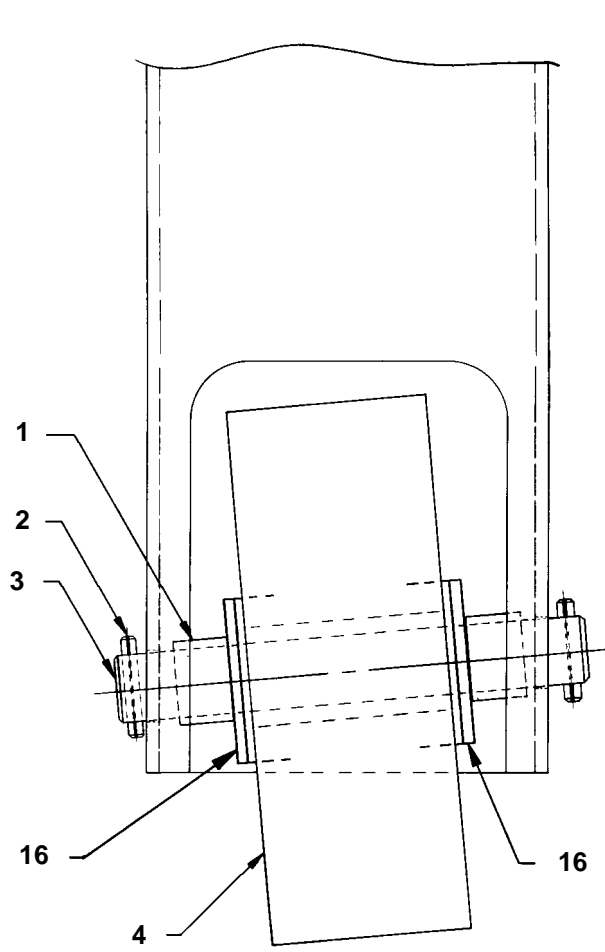

Detail C

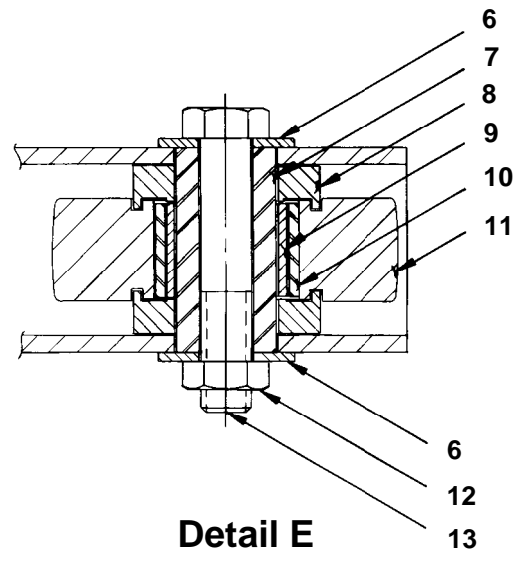

Detail E

Item No.	Part No.	No. Req'd	Description
1	205895	4	Spacer
2	10982	6	Roll Pin
3	207639	3	Pin
4	12026-1	2	Wheel
5	28697	2	Spacer
6	10236	4	Washer
7	207643	2	Bushing
8	207644	4	Spacer
9	207657	2	Inner Bearing Race
10	207658	2	Needle Roller Bearing
11	44821	2	Wheel
12	207254	2	Jam Locknut
13	19340	2	Hex Hd. Cap Screw
14	207634	4	Retaining Ring
15	303229	1	Pin
16	10238	4	Washer

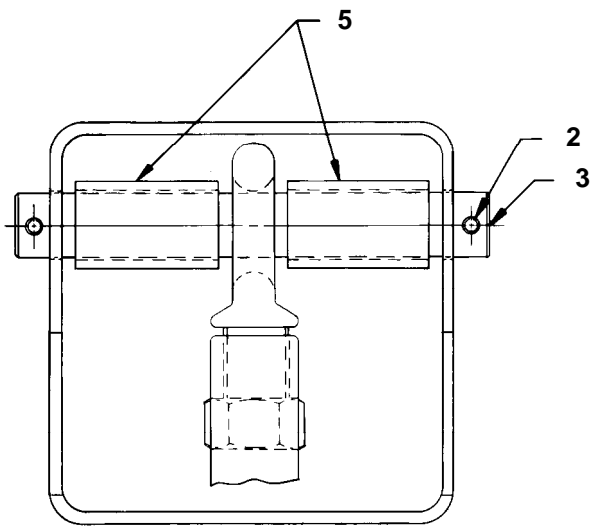

Detail D

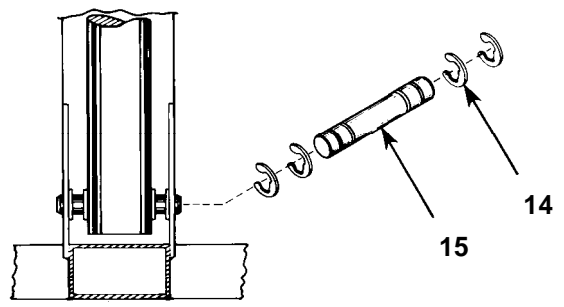

Detail F