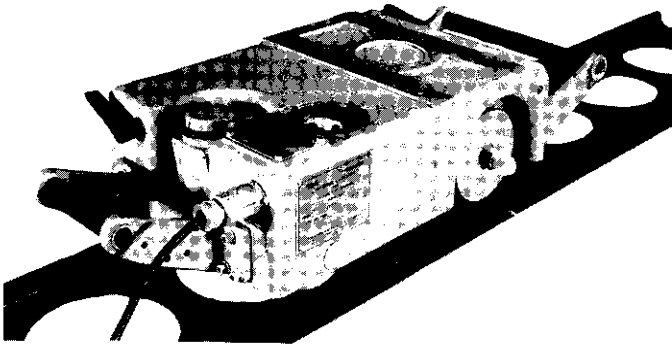

INSTRUCTIONS

for

LINDE

TRADE MARK

CM-37**MACHINE****CARRIAGE**

CONTENTS

I. GENERAL INFORMATION	2	V. DISASSEMBLY	7
II. INSTALLATION	3	A. Motor-Governor-Gear Reduction Unit Assembly	7
A. Clutch Adjustment	3	B. Front Axle, and Worm Drive Shaft	11
B. Friction Drag Adjustment	3	C. Rear Wheels and Axles	12
C. Connection to Power Line	3	VI. TESTING THE ELECTRICAL SYSTEM	13
D. Installation of Carriage Track	4	A. General Inspection	13
E. Installation of Carriage Guide Wheel	5	B. To Test the Motor	13
III. OPERATION	6	C. To Test the Motor Control Switch	13
A. Preliminary Arrangement	6	D. To Test the Governor	13
B. Starting the Carriage in Motion	6	E. To Test the Resistors and Condenser	14
C. Speed Range Adjustment	6	VII. TROUBLESHOOTER'S CHECK LIST	14
IV. MAINTENANCE	6	VIII. REPLACEMENT PARTS	16
A. Lubrication	6	IX. SPEED CONVERSION	25
B. Speedometer Calibration	7		
C. Motor Brush Replacement	7		
D. Governor Contact Replacement	7		

Be sure this information reaches the operator. You can get extra copies through your supplier.



GAS PRODUCTS

I. General Information

The CM-37 is a portable, heavy-duty machine carriage designed for straight-line operations. It is a prime-mover for equipment used in flame-cutting, flame-treating, plate-edge preparation, and electric welding and cutting.

The CM-37 has a cast aluminum frame, reinforced by full-depth webs. This gives high strength and rigidity without excessive weight. In combination with the heavy-duty motor, it permits the CM-37 to carry and propel accessories weighing as much as 500 pounds.

A 115 Volt A.C. reversible motor and gear reduction unit drives the carriage through a helical-worm-and-worm-gear reduction. Torque is transmitted to the front axle through a spring-loaded jaw clutch. The clutch can be disengaged by shift levers at front and rear of the carriage. Both the drive axle and worm drive shaft are mounted in ball bearings to reduce friction and wear. An adjustable drag brake is provided on one of the drive wheels. This brake maintains a constant minimum load in both directions so that gear backlash cannot cause erratic motion.

Stepless speed control is provided, by an eddy-current type governor, over a very wide useful speed range. Four models of the CM-37 are available, with speed ranges as follows:*

- a. CM-37 Low Speed. 1 (2) to 15 inches per minute.
- b. CM-37 Standard Speed. 4 (7) to 50 inches per minute.
- c. CM-37 Intermediate Speed. 10 (15) to 105 inches per minute.
- d. CM-37 High Speed. 20 (30) to 210 inches per minute.

One of these models will cover the work requirements of virtually every user. For unusual requirements, gears and worms for special ratios are available on special order which will enable the user to obtain a speed range which is "tailor-made" to fit a particular application.

Visual indication of speed is provided through an electrical speedometer which is calibrated for the full speed range. This speedometer is recessed in the carriage cover and is shock-mounted, as well as protected by a plastic shield.

* Minimum speeds shown in parentheses are for electric welding. Narrower tolerances in fluctuation at low speeds for electric welding make this distinction necessary.

All operating controls are located close together at one end of the machine: the three-position (forward-off-reverse) motor control lever, the governor speed-control dial, and the clutch shifting lever. The power supply cord is connected to the same end of the machine through a locking connector. An additional clutch lever is provided at the front of the carriage, for flexibility of control. See Figure 1.

All four wheels are hardened for long wear. The two drive wheels have serrated treads to increase traction when operated directly on a flat plate. The wheels on one side are V-grooved for operation on an accessory track (see top of page 3). The carriage has been designed so that rubber-tired wheels can be used, when desired, for operation directly on a flat plate. A carriage guide wheel, Part No. 09V48, may be used to steer the carriage by hand.

There are three distinct sets of tapped mounting holes in the carriage cover. The two circular patterns in the center of the cover each consist of six holes. One pattern has 1/4-in. -20 threads and is used for mounting the CMA-37-B Cross-Feed Vertical Slide and Turret Assembly. The other circular pattern has 5/16-in. -18 threads and is used for mounting electric welding and cutting equipment. The third (rectangular) pattern consists of six 5/16-in. -18 tapped holes and is used for mounting the CMA-37-A Horizontal Cross and Slide Assembly.

Installed on the CM-37 Machine Carriage, this Cross Slide provides a universal mounting on which you can base any one of a number of assemblies such as the C-45 Torch Rigging, the CMA-37-D Plate Edge Preparation Attachment, Flame Treating Assemblies, and others. A lateral travel of eight inches is provided by the Cross Slide. Also available is the CMA-37-G Horizontal Cross Slide Assembly, which provides a 20-inch traverse.

Special apparatus can be bolted to the Cross Slide with little difficulty also. The only requirement

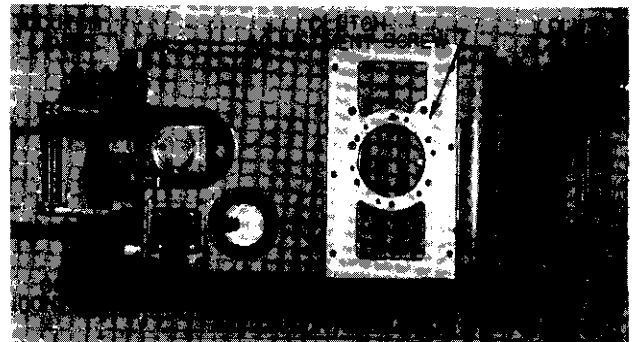

FIG. 1 - CM-37 (Series 2) Carriage Controls

is a simple mounting plate or bracket with appropriate bolt-holes.

Two types of track are available for use with the CM-37. The tracks are similar in size (6-ft. lengths) and shape. They differ chiefly in the fact that only the Precision Track (Part No. 37V15) is provided with dowel pins and clamping plates for coupling of sections to form a continuous track system. Both are of standard I-beam shape, and have one V-rail and one flat rail as required for accommodating the CM-37 wheel system.

The General-Duty Track (Part No. 37N99) is intended for use in operations where purchase economy and mobility are important factors, rather than extreme accuracy of alignment of track sections. It should be found entirely acceptable for the majority of submerged arc welding applications. In most cases this track will be used in single lengths. Ordinary job-shop operations will make frequent use of this type track. It will prove especially useful in situations which require "leapfrogging" several sections of

track for long cuts, where extreme accuracy of alignment is not necessary. For details on the use of this track in permanent installations, refer to the Installation section of this manual.

The Precision Track (Part No. 37V15) is intended for use where linearity in lengths greater than 6 feet is of prime importance. This track is equipped with dowel pins and sockets for accurate alignment of adjacent track sections. In addition, clamping plates are provided for fastening the sections to each other. The Precision Track is especially recommended for use in permanent installations, such as a precision L-bed.

The CM-37 can be operated directly on the surface of a plate (usually the workpiece itself).

In cases where extreme accuracy of straight-line travel is not required, the CM-37 can be operated using a standard 10-inch 25.4 lb. I-beam as a track. The carriage wheels have been designed so that they will ride on the edges of the beam flanges.

II. Installation

The Machine Carriage is shipped completely assembled. It needs only to be removed from its packing crate and placed in position on a flat clean plate or track.

A. Clutch Adjustment

Two types of clutch action are available in the CM-37. Selection of type is made by means of an adjustable setscrew in the top surface of the carriage (see Figure 1). When the setscrew is in its normal position (as received from the factory), the clutch lever can snap into either one of two positions: "engaged," or disengaged." If the setscrew is screwed in to a lower position, the clutch lever will snap into the "engaged" position only. The clutch can be disengaged, but must be held in this position by hand; when the operator lets go of the clutch lever it will automatically snap back into the "engaged" position. This latter characteristic is valuable in operations where it is imperative that carriage and the mounted equipment begin operation simultaneously. It eliminates the possibility that the operator might forget that he disengaged the clutch at the finish of the previous pass.

The setscrew is accessible from outside the carriage (Figure 1), and is adjusted by means of a hex key.

B. Friction Drag Adjustment

Place the shifting lever in the disengaged position and adjust the friction drag. This drag is produced by a spring-loaded pad which presses against the left-hand front wheel. It eliminates backlash and jerky carriage travel by providing a constant minimum load in both forward and reverse directions. The spring tension of the friction pad is adjusted by means of a slotted screw in the side of the carriage frame, behind the right-hand front wheel. Turn the screw counter-clockwise to increase drag, clockwise to

decrease drag. An access hole is provided in this wheel to permit adjustment from outside the carriage. Rotate the wheel until the access hole lines up with the head of the adjusting screw. Then adjust the drag with a screwdriver as shown in Fig. 2. Adjust the drag so that the carriage moves slowly but smoothly when pushed along the track by hand. When correctly adjusted, a pull of 5 to 7 pounds should be required to move the carriage. The friction drag is very essential to smooth clean cutting, particularly when the carriage is operated on irregular or inclined surfaces. It should be one of the first items checked in attempting to correct faulty operation.

C. Connection to Power Line

An accessory 25-ft. power cable assembly (Part No. 37V72) is available for use with the carriage. This consists of a 3-conductor cable and two plug assemblies. One of these plug assemblies has four prongs and fits the matching receptacle on the rear



FIG. 2 - Friction Drag Adjustment

of the carriage. The other has three prongs, for insertion into a three-wire power outlet receptacle, 115 volt single phase, with separate ground wire. This plug can be converted for use in two-wire systems by means of the three-to-two-prong adaptor supplied with the cable assembly. When using an adaptor, the short wire lead protruding from its side should be attached to a suitable ground connection.

When the carriage is to be used for oxy-fuel gas applications or for electric welding and cutting other than submerged arc, the power cable can be used as-is for power supply connection. If the carriage is used for submerged arc welding, the three-wire cable is not required, since a carriage power cable is supplied as an integral part of the submerged arc apparatus. This cable may be equipped with either a four-prong or a three-prong female plug. If four-prong, it can be connected as-is to the matching receptacle on the rear of the carriage. If three-prong, it will be necessary to remove this plug and install in its place the four-prong plug supplied with the CM-37 carriage as part of the power cable assembly. The voltage nameplate beneath the receptacle on the carriage indicates the numbering of the four prongs. Numbers 1 and 2 connect to the carriage motor. Number 3 connects to the speedometer indicator circuit. Number 4 is connected to the carriage frame as a ground wire. Reference to the submerged arc circuit diagram will show which conductor should be soldered to each prong terminal.

D. Installation of Carriage Track

For many applications, a single length of CM-37 track will provide the required amount of machine travel. In such cases, the General-Duty Track (Part No. 37N99) will serve as well as the Precision Track, and will provide the same accuracy of travel.

When a machine travel in excess of 58 or 59 inches is required, more than one length of track will be needed. Multiple lengths of CM-37 track can be used in two ways as a guide for the machine carriage. One is to use several loose sections of track, "leapfrogging" them as the carriage proceeds down its line of travel. The other is to construct a continuous track assembly by fastening any desired number of track sections end-to-end. This assembly can be used as-is for a semi-permanent project-- by resting it on the surface of the workpiece, or on a temporary support alongside the working zone. Or it can be fastened to a rigid supporting structure for permanent use at a desired location.

In any case where a continuous track assembly is to be used, there are two main factors which will affect the accuracy of carriage travel. These are: (1) accuracy of alignment of the track sections, and (2) accuracy of alignment of the supporting structure. The degree to which each factor applies to the Precision Track and to the General-Duty Track is discussed below:

1. THE PRECISION TRACK (Part No. 37V15)

The dimensions of this track are held to close

tolerances during manufacture. For precision coupling, accurately-placed dowel pins and connecting plates have been installed. These features insure accurate alignment of adjacent track sections. When correctly coupled together on a smooth level surface, the track sections provide a continuous, level, straight guide-rail for the machine carriage.

When installing the Precision Track, therefore, the important consideration is the accuracy of the supporting structure. The support must provide the required smooth level surface, to preserve the inherent accuracy of the track construction. To do this, it must:

- (a) Maintain the top surfaces of the track rails accurately in a single horizontal plane.
- (b) Maintain the lengthwise alignment of the track sections.
- (c) Be strong enough and rigid enough to preserve its alignment against vibration and other normal disturbances which might occur during operations.

In other words, there must be no bow in the track, either horizontally or vertically. Any bolts or clamps used to hold the track to the support must not be permitted to draw the rails out of true in any direction. After aligning and securing the track, the rail joints should be blended by careful draw filing.

The track sections are placed in position, aligned, and fitted so that adjacent ends of both rails are in close contact. Using shims under any low sections, align all sections so that the joints between adjacent V-surfaces are as smooth as possible. One method used in obtaining accurate rail alignment is as follows:

- (a) Using independent supports, stretch a length of piano wire alongside, and close to the V-rail.
- (b) Stretch the wire taut. Then level and align it paralleling the position you wish the V-rail to occupy in the finished installation.
- (c) Use this wire as a guide when shimming and shifting the rail sections. The sections can be aligned so that the wire is in contact with the outside V-face of the rail along the entire length of the assembly. Another method is to place V-blocks on the V-rail at intervals along its length. The rails are then aligned so that the outside faces of the V-blocks line up with the guide wire. Levelness of the rail in this case can be checked by placing a straight-edge on the top surfaces of the V-blocks, then placing a level on top of the straight-edge.
- (d) The track sections can then be fastened together, using the supplied clamping bolts.

- (e) The assembly can be secured to its supporting structure in several ways. Bolts, clamps, or welded tabs can be used. Whatever device is employed, be careful that it does not disturb the alignment of the rails, or draw portions of the rails out of true. The piano wire guide will act as a checking means for detecting any warpage or misalignment that might occur.

The top surfaces of the flat rails should be held in the same level plane. However, no effort should be made to align these surfaces in the vertical plane. It is unnecessary, since the straight-line guidance is provided by the V-rails.

NOTE: Joint alignment of the top (horizontal) surfaces of the V-rail side of the track is not necessary. The carriage wheels do not bear upon this surface.

2. THE GENERAL-DUTY TRACK (Part No. 37N99)

This track is intended for use where economy and mobility are important, rather than extreme accuracy of joined sections.

The same precision of straight-line guidance is provided in the manufacture of this track as in the Precision Track. However, no means are provided for joining track sections. In addition, broad tolerances are allowed in the depth of the track section, the location of the center web, the squareness of the track ends, and in other dimensions that are of importance only when joining adjacent sections.

The General-Duty Track is well-suited to single track setups. A pair of tracks can be fitted (by the customer) with joining plates or other devices, to secure quick mating of the ends with satisfactory alignment of the top surfaces. This would be done for use in "leapfrogging" operations, where extreme precision of joining is seldom a requirement. It may be necessary to match and fit the joining plates for the particular ends to be joined, since the dimension between the center web and the top rail surface is not held uniform. If desired, the rail ends may be ground or filed to fit squarely. However, a small gap between one pair of rails of the track will not usually be objectionable in operations where the "leapfrogging" method is used.

The General-Duty Track can also be used to provide a permanent or semi-permanent continuous track assembly. If accurate fitting of the track ends is done during installation, the same accuracy of straightness and joint alignment can be obtained as with the Precision Track.

When assembling several sections of the General-Duty Track into a permanent or semi-permanent installation, the primary considera-

tion will be the alignment of the V-faces of the V-rails.

The supporting structure should first be installed in place. Its top surface should then be trued up to provide a level base on which to mount the track sections. The structure must be strong enough and rigid enough to maintain its initial alignment against vibration and other normal disturbances that might occur during operations.

Installation procedure for the General-Duty Track is the same as that given previously for the Precision Track. However, the customer must provide a means for fastening the sections to each other, since none is supplied. Fish plates (shimmed up, if necessary), straps, or any other practical means can be used.

3. SAFETY HOOKS

It is advisable that CM-37 Carriages operated on track above the floor level be fitted with angle brackets to prevent them from leaving the rails or running off the end of the track. This will prevent damage to the equipment or personnel in the event that the carriage is accidentally tipped or permitted to overrun.

E. Installation of Carriage Guide Wheel 09V48

Although the CM-37 is generally guided along standard track, the guide wheel pictured in Fig. 3 has been made available for hand guiding. The wheel is mounted at the rear of the carriage, and takes the place of track. When mounted, the guide wheel raises the carriage idler wheels off the ground entirely; the resultant three-point suspension makes for easy, accurately controllable manual steering.

As illustrated, the guide wheel mounting bracket is screwed directly to the handle brackets on the carriage with the socket-head screws supplied. The steering handle screws directly into the shank of the wheel fork.

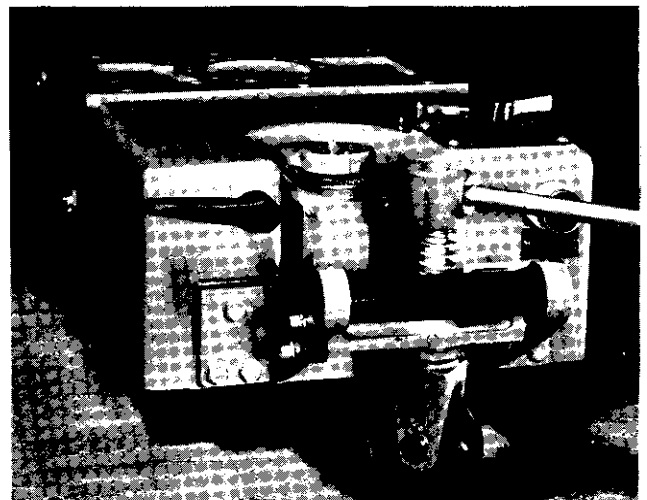

FIG. 3 - Carriage Guide Wheel

III. Operation

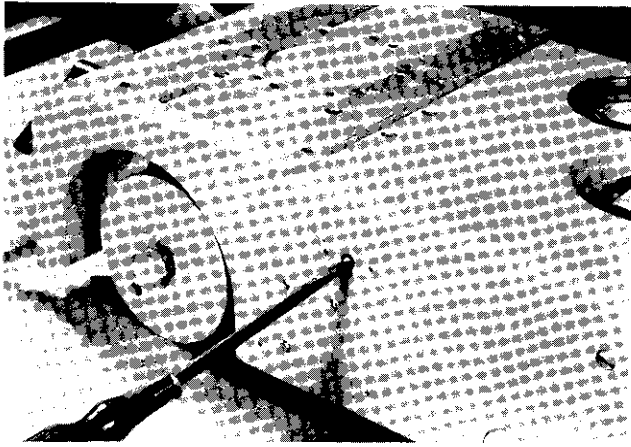

FIG. 4 - Adjusting Rheostat

A. Preliminary Arrangement

Assemble the appropriate equipment on the machine carriage, using the supplied mounting hardware.

Connect the required supply hose and cables. These should be supported in such a manner that a minimum of drag is placed on the carriage.

Before setting the carriage in operation, brush the track or plate clean. Dirt or slag beneath the wheels can cause irregularities in motion of the machine carriage. This in turn may result in flaws in the work being performed.

Place the shifting lever in the engaged position. Turn the motor control lever to an "On" position. With the carriage in motion rotate the governor control dial until the desired carriage speed is indicated on the speedometer. The selected speed will depend on the attachment being used and the thickness of the workpiece. It will be determined as outlined in the instructions and charts packed with the attachment.

Turn the control switch off. Place the shifting lever in the disengaged position, and move the carriage to the desired starting location.

B. Starting the Carriage in Motion

The direction of carriage travel depends upon the position of the motor control lever. When the lever is in one "ON" position, the carriage will move forward. When it is in the other "ON" position, the carriage will move backward.

To start the carriage in motion for performing any operation, two methods are possible. One is to turn on the motor, then move the shifting lever to the engaged position. The second method is to keep the shifting lever in the engaged position and use the motor control lever for starting the carriage in motion. This latter method is preferred, since it provides a smoother start and uses only one control for starting, stopping, and reversing the carriage.

C. Speed Range Adjustment

A 50-ohm, 50-watt rheostat, located in the left side of the carriage (Figure 4), is connected in series with the motor, to provide smooth operation at the lower end of the carriage's speed range. This rheostat is intended as a range selector device. When once set to suit the general speed range requirements of the carriage, it should need readjustment only if a change-over is made from extremely low speeds to extremely high speeds, or vice versa.

Turning the slotted control shaft with a screwdriver counter-clockwise increases the rheostat's resistance; turning the shaft clockwise decreases the resistance. For operation at predominantly low speeds, set the rheostat for maximum, or near maximum, resistance. For operation at predominantly high speeds, set the rheostat for minimum resistance. If operation will be at intermediate speeds generally, set the rheostat at about half the maximum resistance.

IV. Maintenance

The CM-37 Machine Carriage is simply and ruggedly constructed to provide long, trouble-free service. All gears are enclosed in gasketed housings. Exposure of bearings is held to a minimum. The bottom of the machine is enclosed by a cover plate to protect the interior from slag and dirt. The heavy cast aluminum frame shields the working parts from the heat of the work zone. Under these conditions, maintenance problems are few. Actual breakage is rare, since the carriage is built to carry a load of 500 pounds without difficulty. This weight will seldom be exceeded in field operation. Routine maintenance will consist largely of periodic lubrication, checking the speedometer calibration at regular intervals, re-adjusting the friction drag to compensate for wear on the friction pad, and dressing or replacing the motor brushes and the electrical contacts in the governor.

A. Lubrication

The carriage wheel bearings are sealed ball bearings; they require no lubrication. The motor

armature bearings, and the worms and gears in the gear reduction unit (attached to the motor) will ordinarily require no lubrication. The worm drive shaft

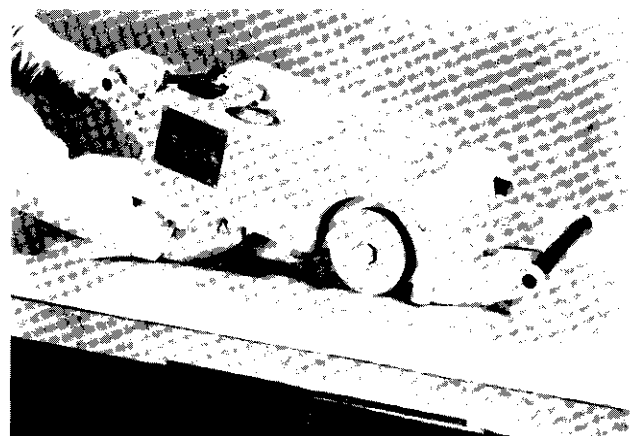

FIG. 5 - Adjusting Speedometer Calibration Rheostat

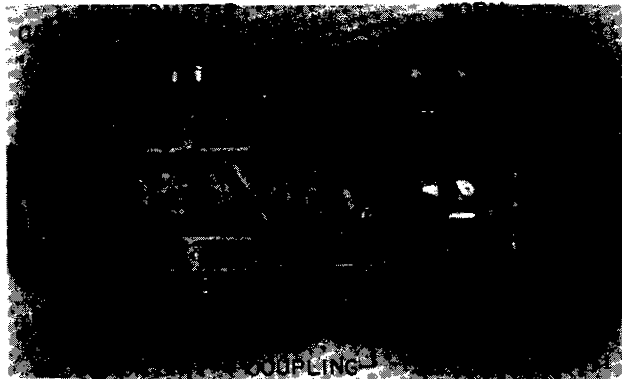

FIG. 6 - Interior of Carriage with the Cover Plates Removed

(located in the covered gear box at the front of the carriage) is mounted in ball bearings. For normal usage, these two bearings and the worm and gear which drive the front axle should be lubricated periodically by swabbing with Royco #6A grease.

If there is excessive wear of the worm and worm gear in heavy-duty service, the gear box should be packed with Royco #6A grease up to the level of the worm shaft. Care should be taken to avoid packing the gear box above the level of the worm shaft.

NOTE: Before removing Royco 6A grease from the container, stir it until it has an even consistency. Any free oil on top of the grease should be mixed in thoroughly. **NEVER** pour off free oil from the top of the can.

B. Speedometer Calibration

When shipped from the factory, the speedometer is calibrated to indicate the speed of the carriage in inches per minute. Due to the effects of heat, aging, replacement of parts, etc., it is necessary to check the calibration periodically, and to correct any drift which may have occurred. This is done by operating the carriage at some speed near the middle of its range, and measuring the distance it travels in one minute. If the speedometer is correctly calibrated, this distance in inches should correspond to the speedometer reading. If the speedometer does not indicate the correct speed as measured, lift the rear of the carriage as shown in Figure 5, and adjust the speedometer rheostat (see Figure 6), (by reaching through the 5/8-in. dia. hole in the bottom cover plate with a screwdriver) so that the speedometer will indicate the measured speed when the carriage is set in motion. If the carriage is carrying apparatus, or for some other reason cannot be lifted as shown in Figure 5, the rheostat can be adjusted while operating the carriage on a section of OXWELD standard track, by reaching through one of the lightning holes in the web of the track.

C. Motor Brush Replacement

Unscrew the brush plugs. Withdraw the metal disc and the brush and spring assembly, noting the

position of each brush in its holder so that it can be replaced in its original position. Examine the brushes.

Make sure that each brush surface in contact with the motor commutator has the polished finish that indicates good contact. The polished area should cover essentially all of the contacting surface of the brush. With brushes removed, inspect the surface of the commutator. It should appear clean and smooth, with a polished brown color where the brushes ride it. If the surface appears to be rough, disassemble the motor and remove the armature (see Disassembly section). Polish the commutator surface with No. 00 sandpaper. Preferably the armature should be rotated in a lathe for this operation.

CAUTION: Never use emery cloth or an emery stone for this operation. Emery is a conductor of electricity, and any residual loose particles may short-circuit the commutator segments during operation of the motor.

See that the mica strips between the commutator segments do not extend above the segments. If this condition exists, the excess mica must be removed, and the strips should be undercut slightly.

When replacing a brush in the motor, be sure to put it back in the same brush holder, and in its original position. Be sure also that the brush rides freely in its holder.

New brushes are approximately 3/4-in. long. When they have worn down to about 1/2-in. in length, they should be replaced with new ones.

Replacement of brushes, and commutator maintenance should be performed only by an experienced electrician.

D. Governor Contact Replacement

After a long period of operation, the governor contact surfaces may become pitted enough to interfere with the proper operation of the governor. It is then necessary either to dress the old contacts or replace them. It is recommended that when contacts are pitted, they be replaced rather than dressed.

The contacts should be dressed with an ignition-type file, but emery cloth or sandpaper may be used. The dressed surface should be smooth, and parallel to the original contact face. Be sure to remove all traces of filings, emery, or sand, and that the contacts are free from oil and grease.

To replace governor contacts, disassemble the contact unit assembly from the governor as explained in the Disassembly section of this manual. The contacts can then be easily unscrewed and new ones substituted. When installing a contact, be sure that it is screwed in up to its shoulder. It is not advisable to replace a single contact. For best operation, both contacts should be replaced at the same time.

V. Disassembly

A. Motor-Governor-Gear Reduction Unit Assembly

1. Stand the carriage on its side and remove the bottom cover plate.
2. Remove the fiber plate which covers the terminal strip, by unscrewing the two nuts which secure it.
3. Disconnect the six motor leads from the terminal strip.
4. Disconnect the speedometer cable plug from its socket on the governor housing.
5. Supporting the motor with one hand, withdraw the four socket-head screws which hold the motor-governor-gear reduction unit assembly to the carriage frame. The heads of the screws are accessible from the top surface of the carriage.
6. Remove the assembly carefully. Do not lose the small coupling block which connects the assembly output shaft to the worm drive shaft. This coupling block will fall free when the assembly is withdrawn.
7. Withdraw the four screws which hold the gear reduction unit to the motor housing. The unit can then be lifted off. If the gasket seal between the unit and the motor housing does not release easily, tapping the unit on several sides with a rawhide mallet will usually release it. Disassembly of the gear reduction unit is as shown in Figure 27 Replacement Parts Section.
8. To remove the governor, it must first be disassembled. The procedure is as follows: (Refer to Figure 25, Replacement Parts Section.)
 - (a) Remove the top cover (31W32) by withdrawing the two screws which hold it on the governor housing.
 - (b) Lift off the Control Dial Assembly (27W15) as in Figure 7.
 - (c) Remove the front cover (27W16) by withdrawing the four screws which hold it on the governor housing.
 - (d) Remove the two fillister-head screws which hold the Contact Spring Block (45N87) as shown in Figure 8 and pull the block forward until it hangs free.
 - (e) Remove the three round-head screws which hold the Contact Unit Assembly (16V64) on the top of the governor housing, then lift the Contact Unit Assembly as in Figure 9. As the Assembly is lifted, the block and chains should be guided through the governor housing by hand to avoid damage to the parts. It cannot be removed completely, since as the figure shows, the governor leads are attached to its terminals.



FIG. 7 - Removing Control Dial



FIG. 8 - Withdrawing Collar Screws

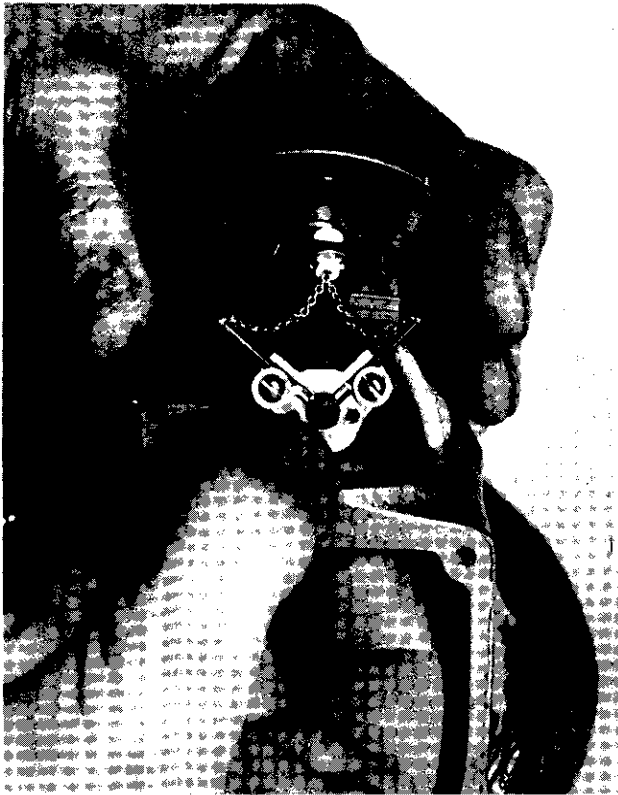

FIG. 9 – Lifting Out Contact Unit Assembly

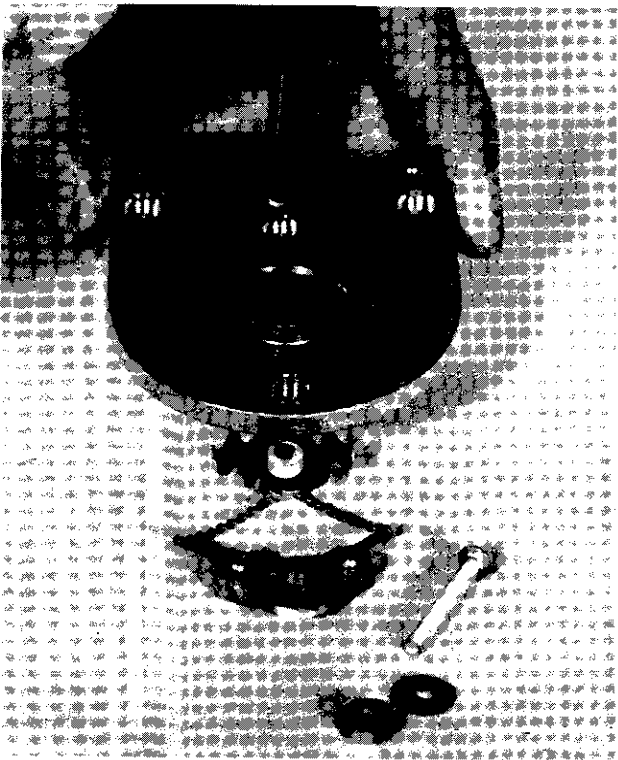

FIG. 10 – Disassembling Contact Unit Assembly

- (f) Make a note of the color (or number) of the wire which is attached to each terminal. Withdraw the terminal screws. Detach the wires and remove the Contact Unit Assembly. The contacts may now be conveniently cleaned or dressed. For replacement of contacts, see below.
- (g) To disassemble the Contact Unit Assembly, remove the two long machine screws shown in Figure 10. The individual contact springs, spacers and terminals will then separate.

The contacts may now be unscrewed and replaced if required. (Contacts should always be replaced in pairs.)
- (h) Remove the three small screws which hold the spider (26W03) in the governor housing. Remove the spider. (Figure 11)

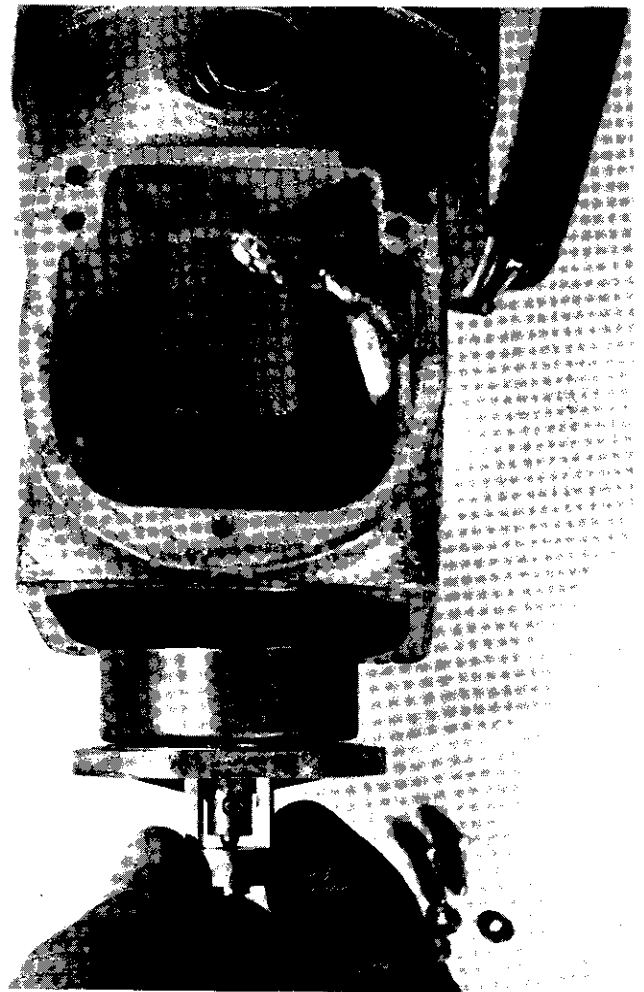

FIG. 11 – Removing Spider and Cup Assembly

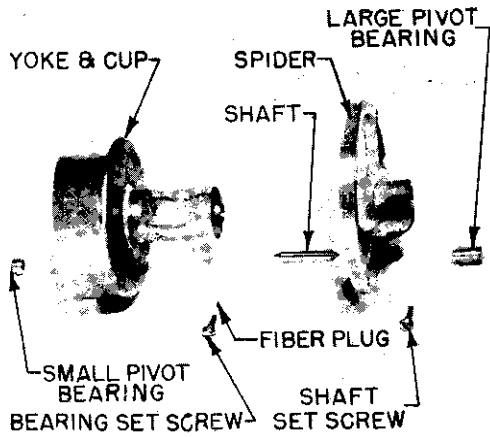

FIG. 12 - Spider Group Disassembled

- (i) The Yoke and Cup (13V35) which is mounted in the spider is removed by first loosening the small round-head screw which holds the large pivot bearing (13V22). Then unscrew both bearings (13V21 and 13V22) from the yoke. Loosen the round-head setscrew in the spider. Remove the bearing shaft (26W52). Then lift out the spider. A disassembled view is shown in Figure 12.

In reassembly, note that the small bearing (13V21) fits into the cup end of the yoke, and screws in tight against a shoulder. Adjustment of the pivot bearings is done by means of the large bearing (13V22) in the outer end of the yoke. Try the spider-and-

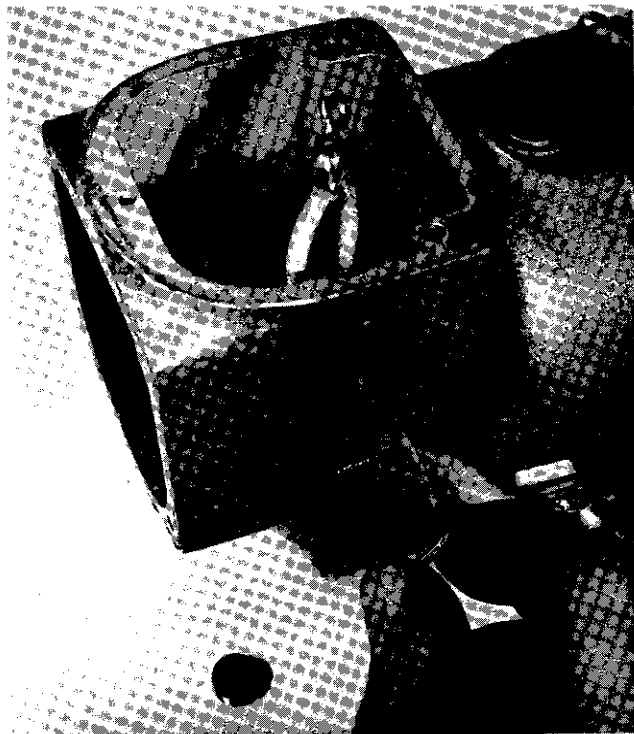

FIG. 13 - Loosening Magnet Setscrew

cup assembly for free pivoting of the cup on its bearings without excessive end play. It is not practicable to eliminate end play altogether. Adjust for a barely perceptible amount of end play by turning the slotted end of the bearing in the outer end of the cup yoke. Make this adjustment carefully, trying the end play frequently as the position of the bearing is changed. Care must be taken not to draw the bearings up snug, as this might crack the jewels or blunt the pivot points. There is a setscrew on the lower side of the cup yoke, opposite the contact lever arm, which must be loosened before the bearing can be adjusted. Tighten this setscrew after adjustment is completed.

There must be clearance between the back of the cup and the face of the spider. This clearance must not exceed 1/32 inch. If adequate clearance is not present, or if the clearance is excessive, loosen the round-head setscrew in the top of the bracket at the center of the spider; place a 1/32-in. shim between the back of the cup and the face of the spider, and, holding the cup and spider against the shim, tighten the setscrew. Remove the shim.

- (j) Remove the screw plug (26W63) from the side of the governor housing (Figure 13). Looking into the hole, rotate the magnet (26W84) until the magnet setscrew (81W33) on the magnet hub lines up with the hole. Loosen, but do not remove, the setscrew. The magnet can then be removed by inserting a screwdriver through the plug opening and prying against the magnet hub. Do not pry against the magnet itself.

- (k) After removal of the magnet you will see four fillister-head screws in the back of the governor housing. Withdrawing these screws will permit the governor housing to be completely removed.

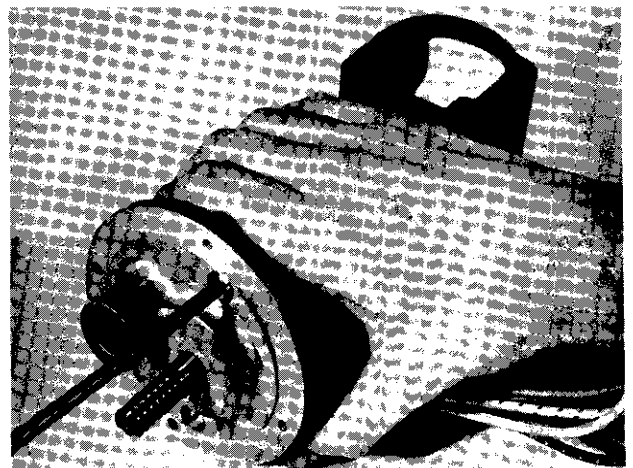

FIG. 14 - Unscrewing Motor Housing Screws

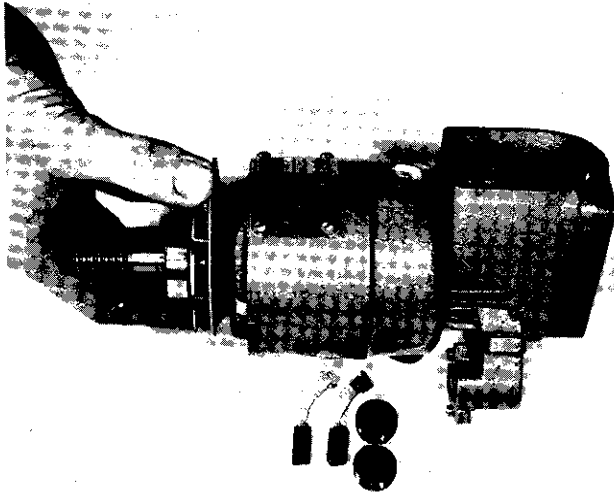

FIG. 15 – Removing Armature

9. Disassembly of the motor is as follows:

- (a) The gear reduction unit must first have been removed and the governor disassembled as previously described. It is not necessary, however, that the governor housing be removed.
- (b) Remove the motor brush plugs and brushes. (Substitute new brushes if required.)
- (c) Unscrew the two motor housing screws as shown in Figure 14.
- (d) Withdraw the motor end housing.

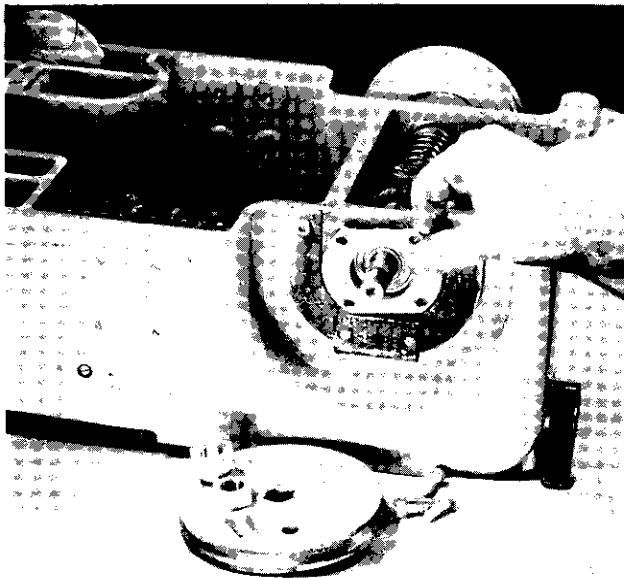

FIG. 16 – Removal of Wheel and Bearing Retaining Plate

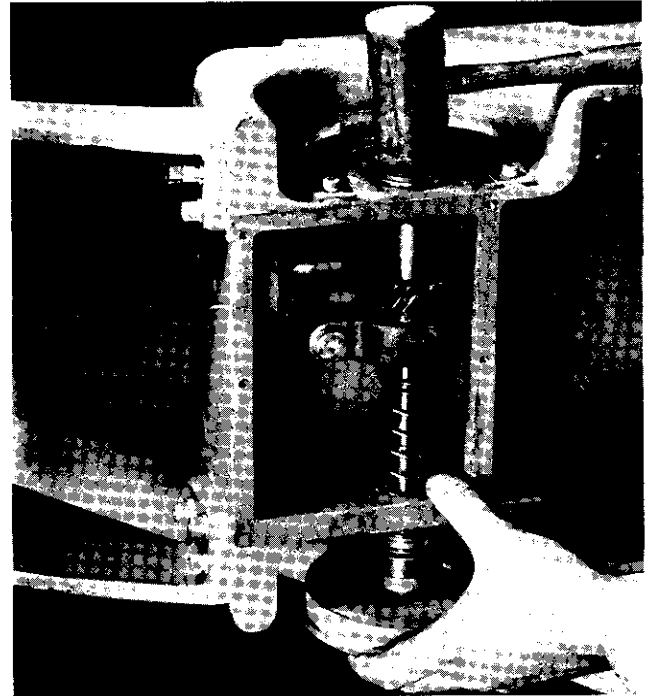

FIG. 17 – Driving Out Front Axle Group

- (e) Remove the armature by tapping with a mallet or wooden stick on the extension shaft at the governor end of the armature. (Figure 15)
- (f) Further disassembly of the motor is as shown in Figure 24 Replacement Parts Section.

B. Front, Axle, and Worm Drive Shaft

1. Release the tension on the drag brake by screwing in on the adjusting screw (Figure 2).
2. Place the carriage on its back. Remove the motor-governor-gear reduction unit assembly from the carriage, as outlined in the previous paragraph V-A.
3. Remove the gear box cover by withdrawing the eight screws which secure it.
4. Remove the wheel by unscrewing the acorn nut and locknut which secure it, then pulling the wheel off the shaft. Refer to Figure 16.
5. Remove the two feather keys from the shaft.
6. Remove the bearing retaining plate (see Figure 16) by withdrawing the four cap screws which hold it to the frame.
7. Place the carriage on its side as shown in Figure 17.
8. Drive out the front axle group as shown, using a rawhide mallet. The two parts of the gear clutch will remain in position and can be lifted out after removal of the axle.



FIG. 18 – Removing Plug

9. Remove the plug from the front of the carriage, as shown in Figure 18, by withdrawing the four socket-head screws which secure it.
10. Withdraw the worm drive shaft and its attached parts by pulling it forward through the front of the carriage. When the front ball bearing is clear of the carriage body, remove the snap ring from this bearing. This will permit the bearing to clear the carriage's front handle. The entire shaft assembly can then be removed completely from the carriage.
11. For further disassembly, refer to Figure 19, which shows a partially exploded view of the worm drive shaft and its associated parts.

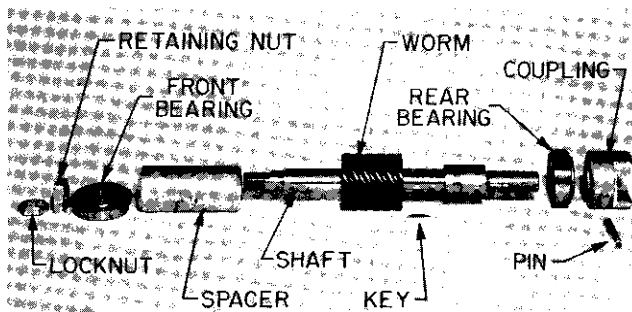

FIG. 19 – Worm Drive Shaft Group, Partially Disassembled

C. Rear Wheels and Axles

1. To remove the left rear wheel:
 - (a) Remove bottom cover plate.
 - (b) Remove the plug button which plugs the access hole in the side of the carriage opposite the left rear axle. This button can be pressed out from inside the frame.
 - (c) Drive out the pin which holds the wheel shaft in the carriage frame.
 - (d) The shaft can then be pressed out through the access hole in the side of the carriage. The wheel and its spacer will fall free when the shaft is withdrawn.
2. The right rear wheel is removed in the same manner as above, with one exception: The wheel shaft in this case is secured by two pair of screws. Each pair consists of a socket-head setscrew which bears against the wheel shaft, and a hollow lock screw which locks the setscrew. The same hex key fits both setscrew and lock screw. Insert the key in the lock screw and loosen it. (Figure 20) Then insert the key all the way in and loosen the setscrew. Raise the setscrew sufficiently to clear the wheel shaft completely, to avoid shearing the setscrew or scoring the shaft during its removal.

The right rear wheel shaft is an eccentric shaft. This permits the operator to adjust the carriage so that all four wheels are in equal contact with the plate or track, in the event that such an adjustment becomes necessary. After loosening the lock screws and setscrews, the wheel shaft can be rotated until equal wheel contact is achieved. The shaft is rotated by means of a wrench clamped on the hexagonal hub of the shaft.

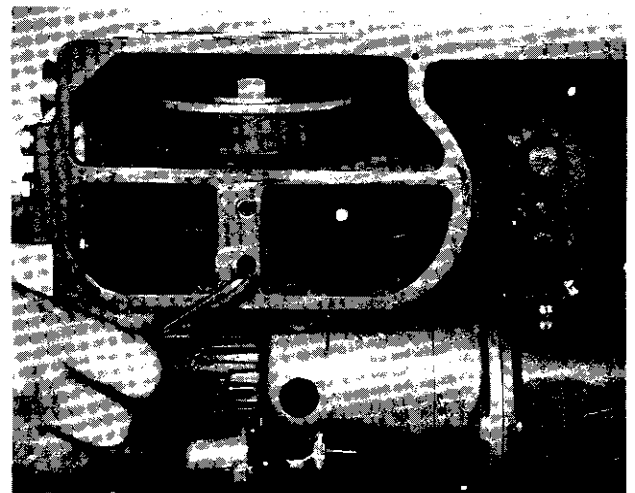

FIG. 20 – Loosening Setscrews on Right Rear Wheel Shaft

VI. Testing the Electrical System

CAUTION: Always disconnect the carriage power cable from the power line while making adjustments or repairs in the electrical system.

Materials required for testing are:

1. A 15 watt light bulb, mounted in a portable socket. The socket leads must be insulation-covered and should be about a foot long.
2. Several short lengths of insulated wire for use as jumpers.
3. An ohmmeter. This instrument is required when making a complete test of resistors and condenser.

Test Procedure for Electrical System

First test the 115 volt a.c. power line for voltage by inserting the test lamp leads in the power receptacle.

Turn the carriage upside down. Remove the bottom cover plate and the terminal cover plate as shown in Figure 6.

A. General Inspection

Examine the electrical system for obvious faults such as broken wires, loose connections, burnt resistors. Examine the wires closely for worn or broken insulation; possible locations for a short or open circuit. Inspect the inside of the governor for loose connections, short circuit, burnt or pitted contacts.

B. To Test the Motor

(Refer to diagram on fiber terminal strip cover plate)

1. Turn the motor control lever to the OFF position.
2. Connect a jumper wire from terminal LO to terminal 7. (Both are on the terminal strip. See Diagram)
3. Connect a jumper wire from terminal LA to terminal B2 on the terminal strip.
4. Withdraw the screws from the motor switch mounting plate, and lift out the switch. Connect a jumper from LB to A1 on the switch. (Figure 28) Note that these terminals on the switch are marked "B" and "2."
5. Make sure that the control switch is off, and that the connections made in steps 3 and 4 stand free and do not touch other terminals or the carriage cover.
6. Plug the carriage power cable in the 115 volt a.c. power receptacle. The motor should now run at a constant high speed. If it does not run, examine the motor leads for breaks or loose connections. Check the motor brushes to see that they are not loose, stuck, broken, or excessively worn.

If inspection does not reveal the trouble, the motor should be replaced with one known to be in good condition.

Remove the Jumpers after making the tests.

C. To Test the Motor Control Switch

1. Disconnect the lead from terminal LA on the switch (Figure 26).
2. Connect a jumper between terminals B2 and A1 on the switch.
3. Connect one test lamp lead to terminal LA on the switch and connect the other test lamp lead to terminal LO on the carriage terminal strip.
4. Plug the carriage power cable into the 115 volt a.c. power receptacle. If the switch is functioning correctly, the lamp will light when the switch is in the FORWARD and REVERSE positions and will go out when the switch is in the OFF position.

Do not forget to remove the jumper and replace the loose LA lead-wire after making the test.

D. To Test the Governor

1. Remove the governor top cover, control dial, and side cover.
2. Insert a piece of heavy cardboard or fiber sheet between the governor contacts.
3. Connect one test lamp lead to terminal LB on the switch. Connect the other test lamp lead to terminal 8 on the terminal strip.
4. Plug the carriage power cable into the 115 volt a.c. power receptacle. Unless there is an open circuit in the 50 ohm rheostat or connections, the test lamp will light.
5. Rotate the rheostat control shaft (Figure 4). The test lamp should vary slightly in brightness as the shaft is rotated, but should remain lighted in all positions of the control shaft.
6. If the rheostat and its wiring are in good condition, the governor contacts can be tested. First disconnect the carriage power cable.
7. Remove the test lamp lead from terminal 8 on the terminal strip and connect it to terminal 7. Then connect the carriage cable to the power line again. The test lamp should glow dimly.
8. Remove the cardboard from between the governor contacts. If the contacts are in good condition and functioning properly, the contacts will touch and the test lamp will then burn with full brilliance. If there is no change in brilliance when the cardboard is removed, examine the contact leads for breaks or loose connections. The contacts may be burnt, the oxide acting as an insulator.

E. To Test the Resistors and Condenser

(Carriage must be disconnected from Power Line.)

For testing the resistors and condenser, an ohmmeter is recommended. The procedure is as follows:

1. Disconnect the six motor leads from the terminal strip.
2. Touch the ohmmeter test prods to terminals 7 and 8 on the terminal strip. If neither of the 700 ohm resistors is shorted or open, a reading of approximately 350 ohms will be obtained. If the reading differs appreciably from 350 ohms, each of the two 700 ohm resistors should be disconnected and

tested individually. A defective resistor must be replaced.

3. Place the meter test prods on terminals LO and 7. The reading should vary from zero to 50 ohms as the rheostat control shaft is rotated from minimum to maximum.
4. To test the condenser for a short or for leakage, unsolder and remove the lead from one of the condenser lugs. Touch the meter test prods to the two condenser lugs. Should the meter show a resistance reading, even on high range, this indicates that the condenser is defective and should be replaced.

VII. Troubleshooter's Checklist

TROUBLE	POSSIBLE CAUSES	REMEDIAL ACTION
1. Motor does not run.	1. Electric power is not reaching motor. (Defective power cord, plug, or switch.)	1. Check for voltage at the power supply outlet. If there is voltage at the outlet, check for voltage at the terminal strip under the chassis. See Section VI. Repair or replace power cable or plug if found defective.
	2. Motor brushes may be too short, or broken, or may be sticking in the holder.	2. Replace the brushes. To prevent sticking, clean brushes and holders.
	3. Governor contacts may be dirty.	3. Re-dress or replace.
	4. Resistor may be burned out.	4. See Section VI. Replace.
	5. Commutator may be dirty, or mica may extend above commutator segments.	5. Clean commutator, or undercut mica.
	6. Motor may be burned out or otherwise damaged.	6. Repair, replace, or return to factory for repair. See Section VI.
2. High speeds cannot be obtained.	1. Rheostat may be incorrectly set.	1. Rotate rheostat clockwise.
	2. Rheostat may be defective.	2. Test as directed in Section VI. Replace if required.
	3. Motor commutator may be dirty.	3. Clean commutator, brush-end housing, and brush holders.
	4. Motor may be overloaded.	4. Using an ammeter, check current drawn by motor. If it exceeds 1 ampere, check gearing for interference or binding.
	5. Line voltage may be low.	5. Provide 110-115 volts line voltage.

TROUBLE	POSSIBLE CAUSES	REMEDIAL ACTION
3. Low speeds cannot be obtained.	1. There may not be enough slack in the governor chains.	1. Readjust the lever arms to secure slack in the chains when the governor dial is set for low speed.
	2. The governor dial stop may be incorrectly set.	2. Readjust the dial stop position.
	3. The governor magnet may be weak.	3. Replace with a new magnet.
	4. Rheostat may be incorrectly set.	4. Rotate rheostat counter-clockwise.
	5. Rheostat may be defective.	5. Test as directed in Section VI. Replace if required.
	6. Resistor may be shorted out.	6. Test Wiring. See Section VI. Repair or replace as needed.
4. Machine travel is uneven.	1. Friction or binding in gear mechanism.	1. Check alignment and wear of parts, particularly bearings.
	2. Dirty or uneven track.	2. Clean and straighten. Replace if necessary. Track should be set in level position without warp.
	3. Motor may be misaligned.	3. Make sure that the Motor-Governor-Gear Reduction Unit Assembly is fully seated in the chassis and held securely by the mounting screws.
	4. Defective Governor.	4. Check governor for loose connections, dirty or pitted contacts, loose screws or pivot, cracked or improperly set bearings, dirt in governor cup, loose magnet set-screw, interference between cup and magnet, or between cup and housing.
	5. A 700 ohm resistor may be open.	5. Test as described in Section VI. Replace if necessary.
	6. The condenser may be burned out.	6. Test as described in Section VI. Replace if necessary.
5. Motor runs at one speed.	1. A 700 ohm resistor may be shorted out.	1. Test as described in Section VI.
	2. Condenser may be shorted.	2. Test as described in Section VI. Replace.
	3. Governor contacts may be welded together.	3. Replace contacts.
	4. Motor lead may be grounded.	4. Inspect wiring for short circuit to ground. Replace the lead or tape the break in the insulation.

VIII. Replacement Parts

How to Order Replacement Parts

- All replacement parts are keyed on the drawings which follow. Two types of numbers are used on these drawings:
 - Standard Part Numbers.** These are usually formed by two pairs of digits with a letter between (for example: 01N21, 18V69). A few parts may have straight digits sequence (3389) (654221). Each standard part number is accompanied by a descriptive word or words.
 - Hardware Numbers.** These are eight-digit numbers. (For example: 6120-3910.) Hardware numbers are usually accompanied on drawings by a one word description.
- Order standard parts by part number and part name, as shown on drawings. **DO NOT ORDER BY PART NUMBER ALONE.**
- For hardware, look up number in hardware list at back of book. You will find there a full description. "Hardware" items can usually be purchased locally.
- When ordering, be sure to state quantity of each part needed.
- Always state the serial number of the machine on which the parts are to be used. The serial number is stamped on the unit nameplate.
- Indicate any special shipping instructions.
- Order replacement parts from the Linde Distributor or Linde region office nearest you.

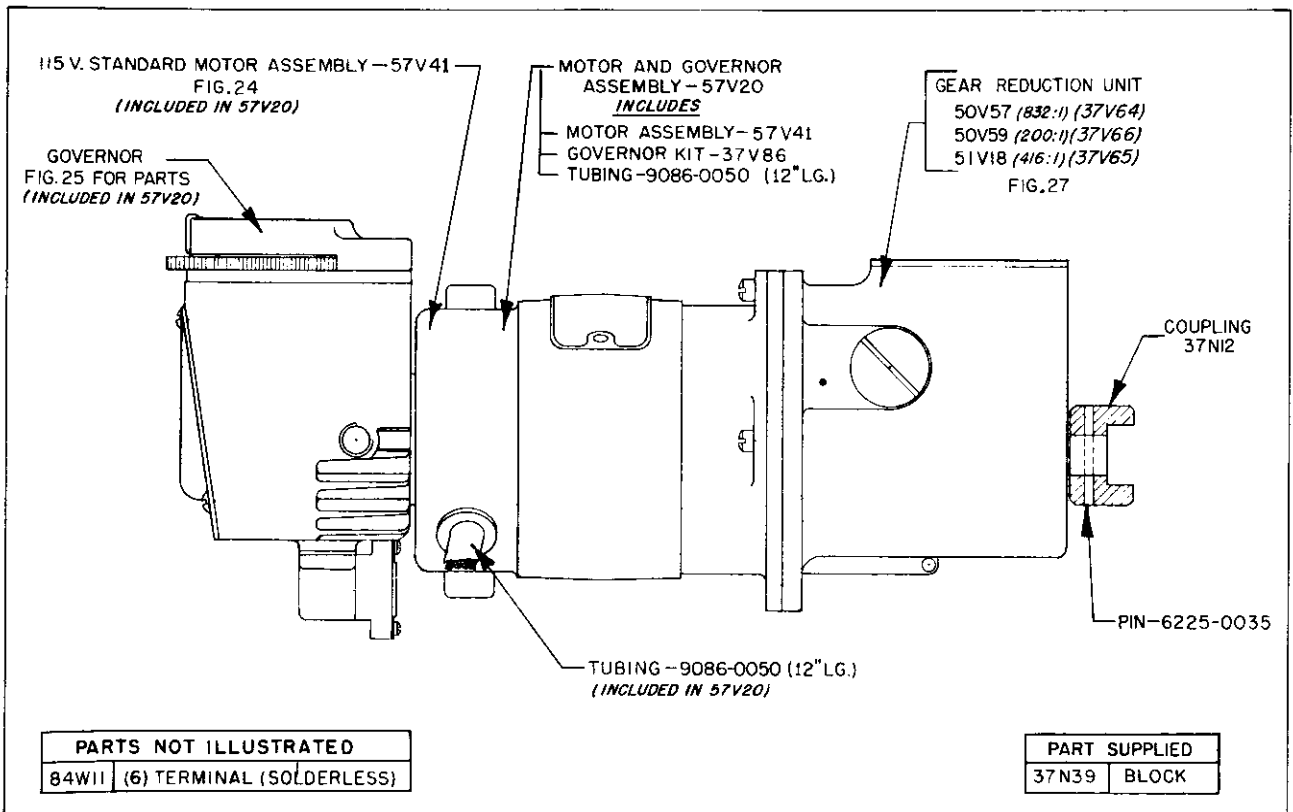
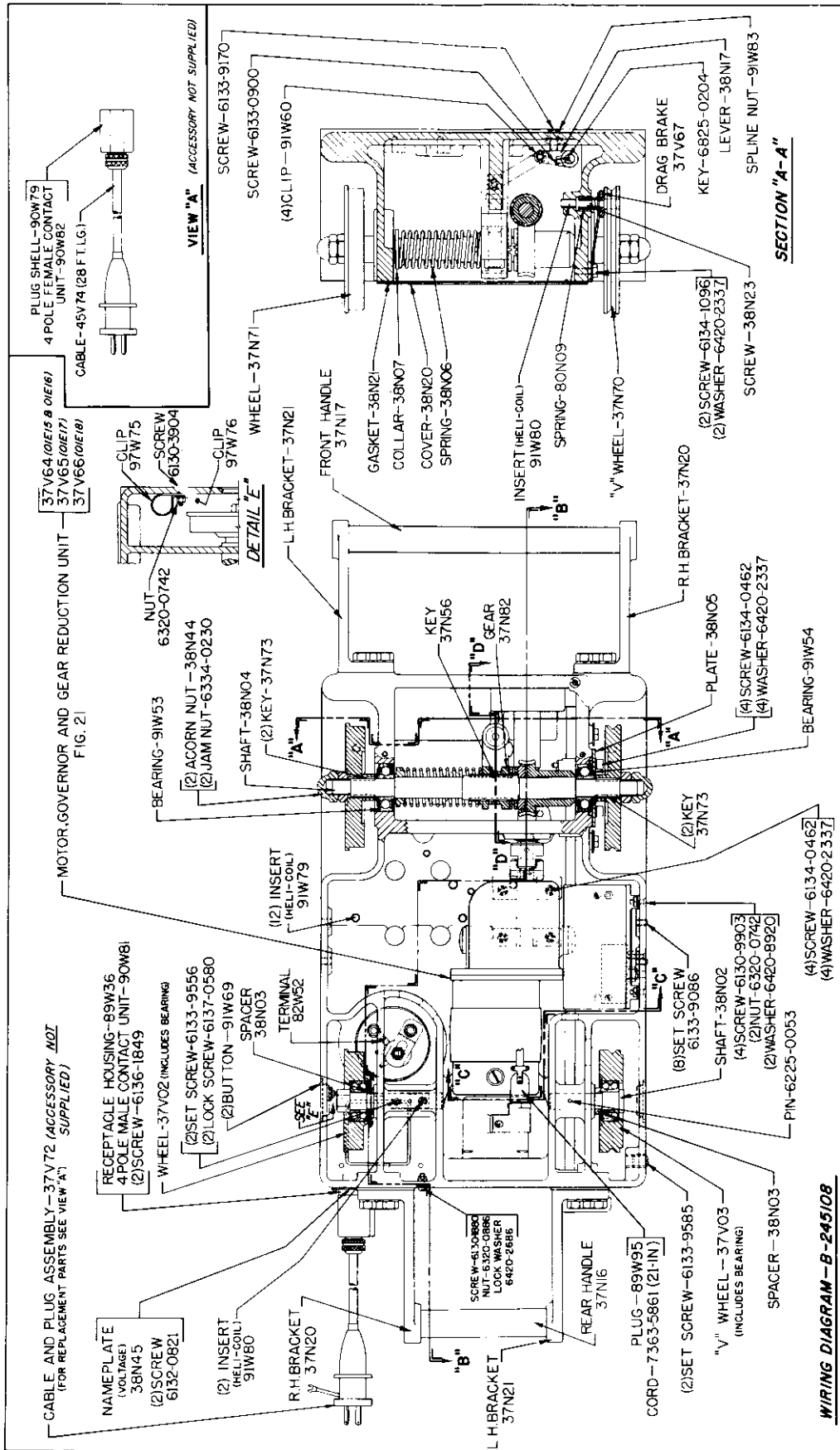

FIG. 21 - Motor, Governor and Gear Reduction Unit Assemblies

37V64(01E15 & 01E16)
37V65(01E17)
37V66(01E18)



- (L)01E15 - Low Speed
- (S)01E16 - Standard Speed
- (M)01E17 - Medium Speed
- (H)01E18 - High Speed

NOTE: For sectional views, see Fig. 23

FIG. 22 - CM-37 Series 2

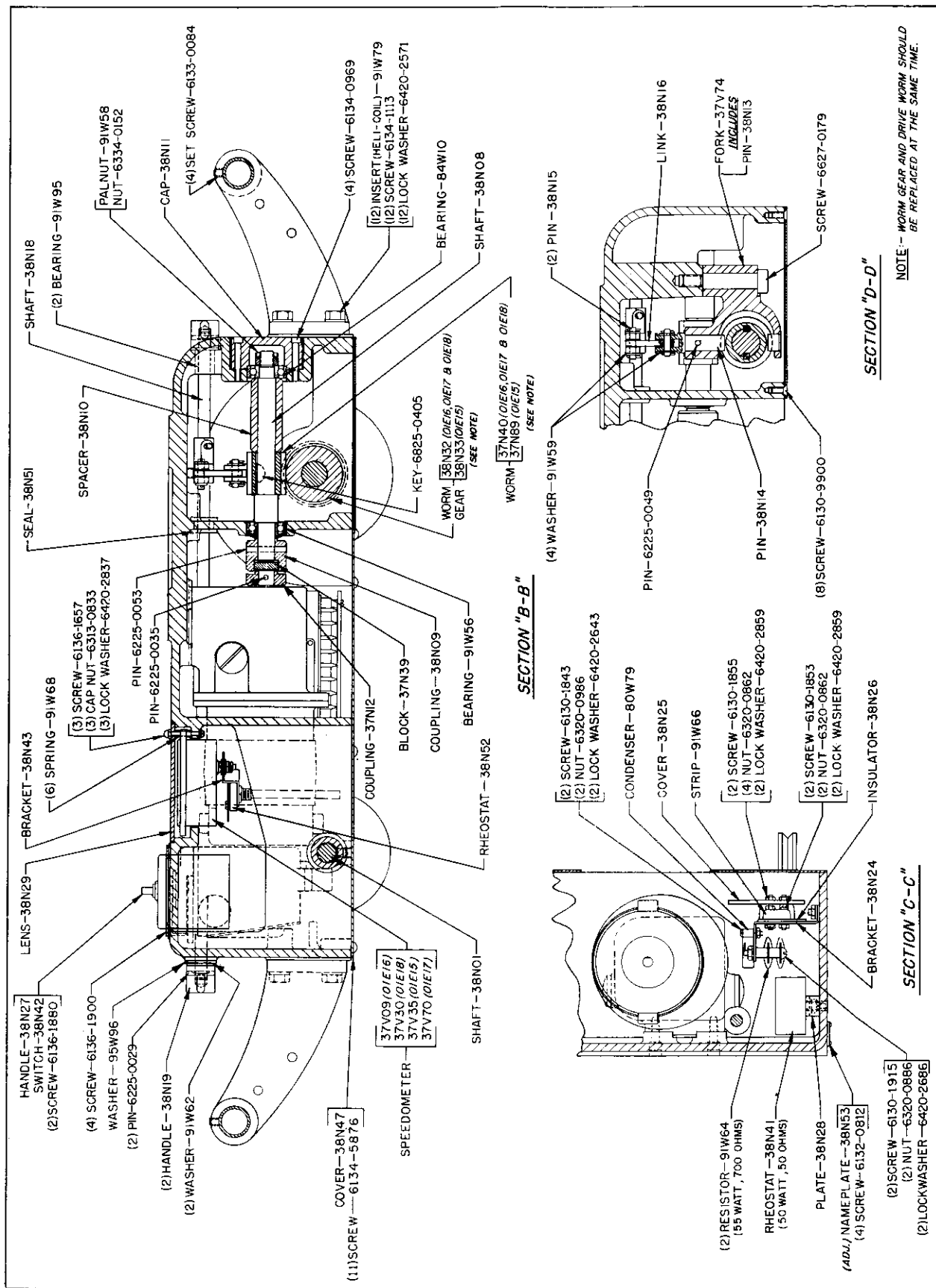

FIG. 23 - CM-37 Cross Section Views

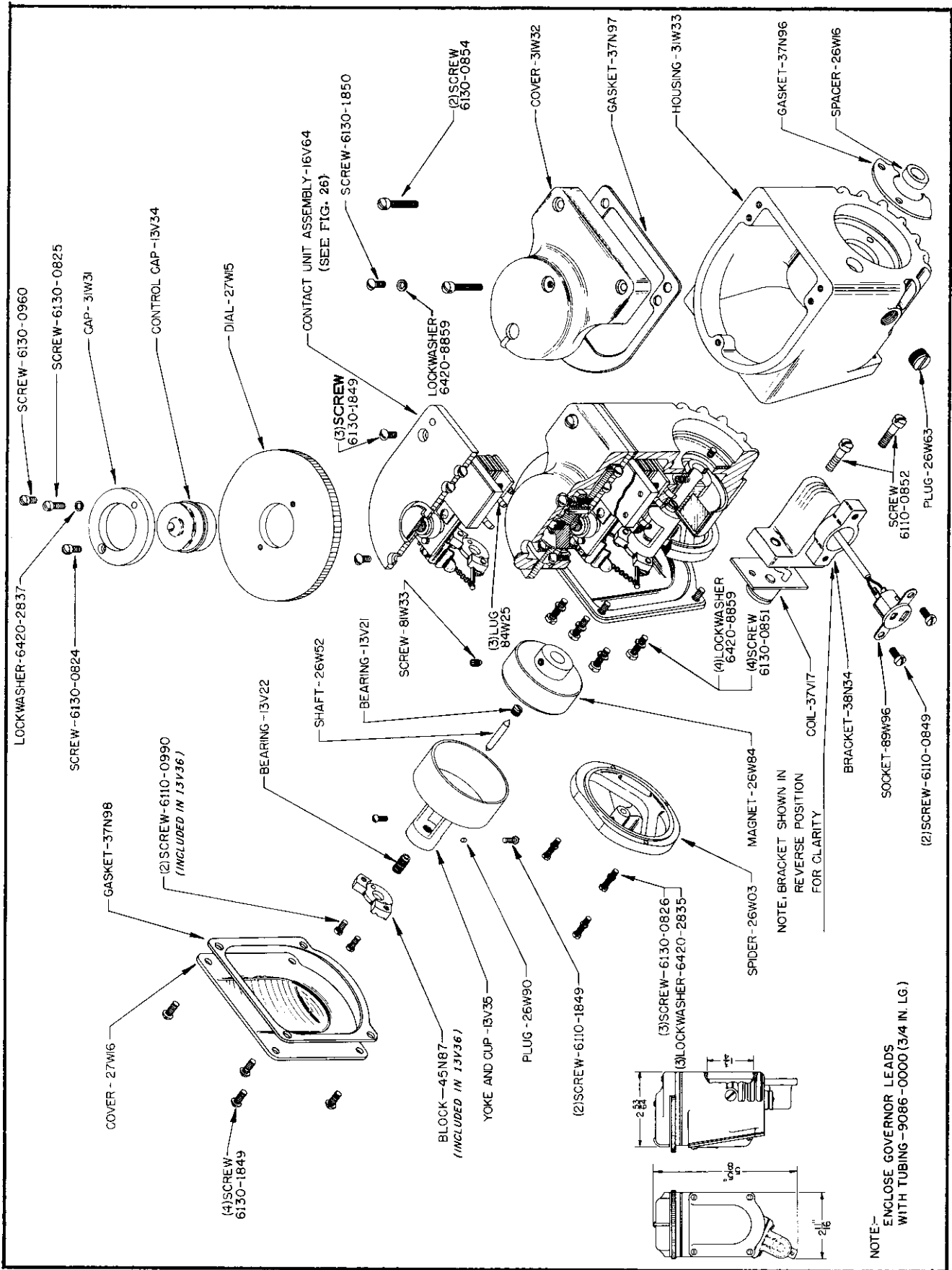

FIG. 25 - CM-37 (Series 2) Governor Kit - Part No. 37V86

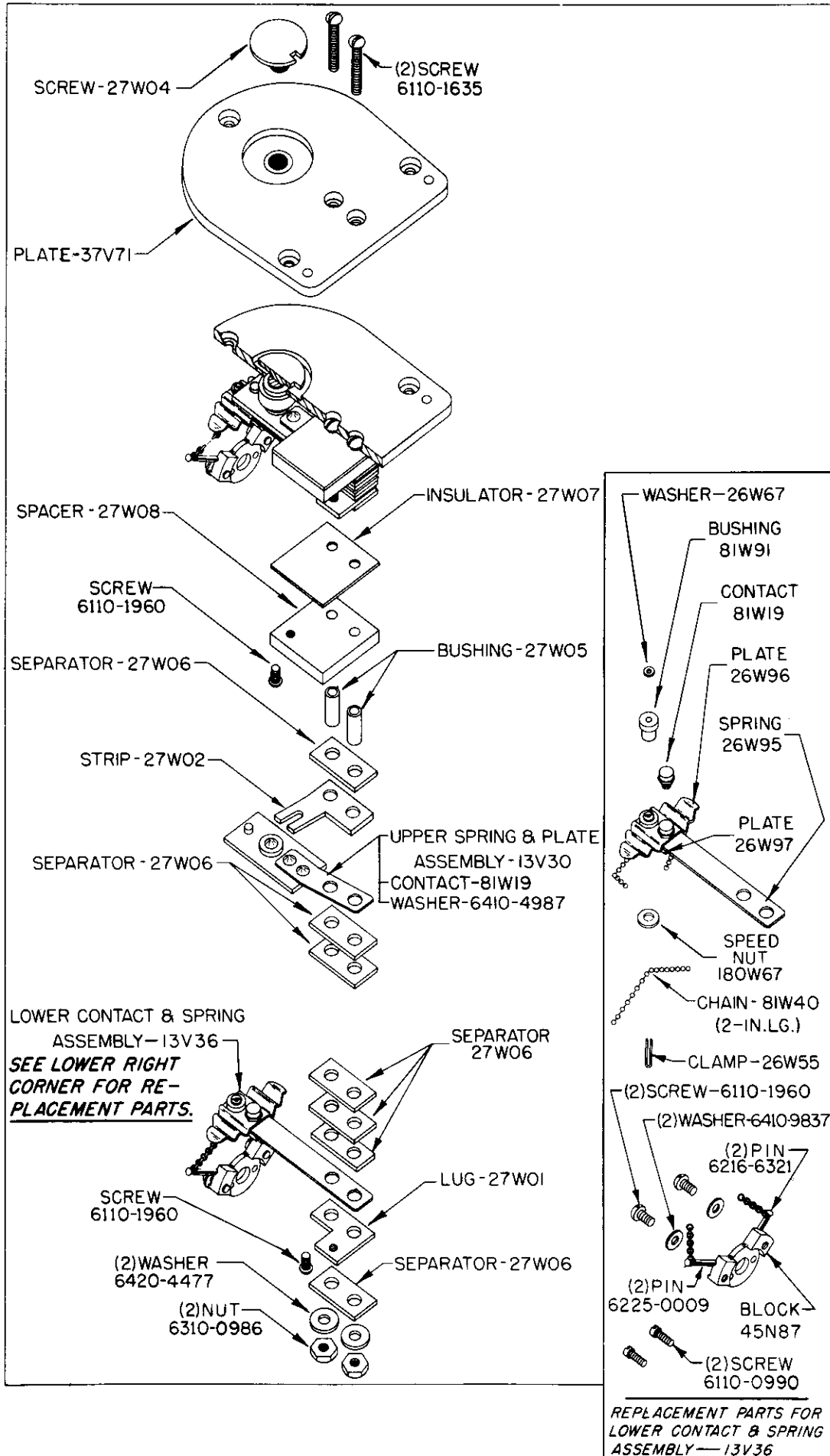
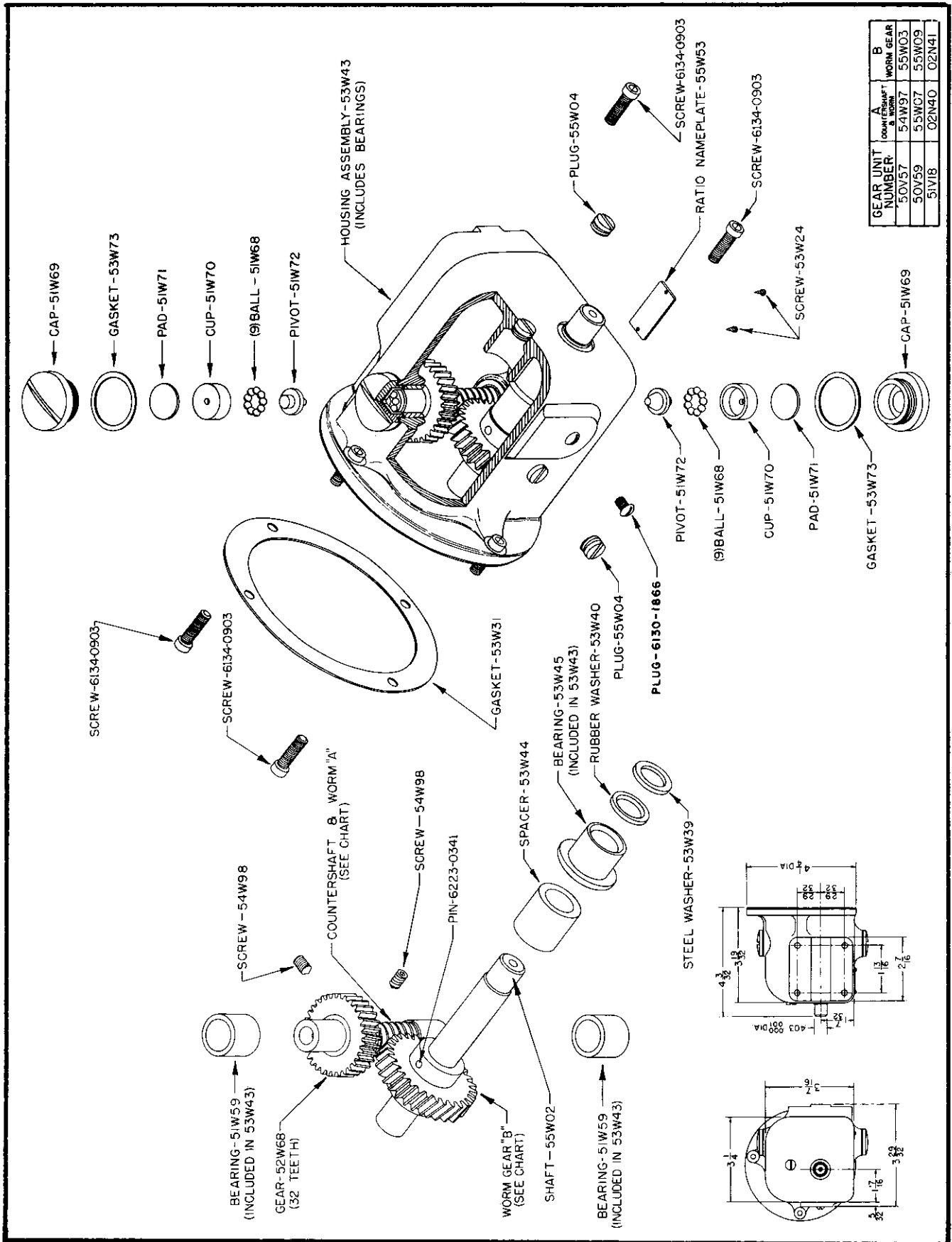

FIG. 26 - Governor Contact Unit Assembly - Part No. 16V64



GEAR UNIT NUMBER	A COUNTERSHAFT & WORM	B WORM GEAR
50V57	54W97	55W03
50V59	55W07	55W09
51V18	02N40	02N41

FIG. 27 — 832:1 Gear Reduction Unit — 50V57
 200:1 Gear Reduction Unit — 50V59
 416:1 Gear Reduction Unit — 51V18

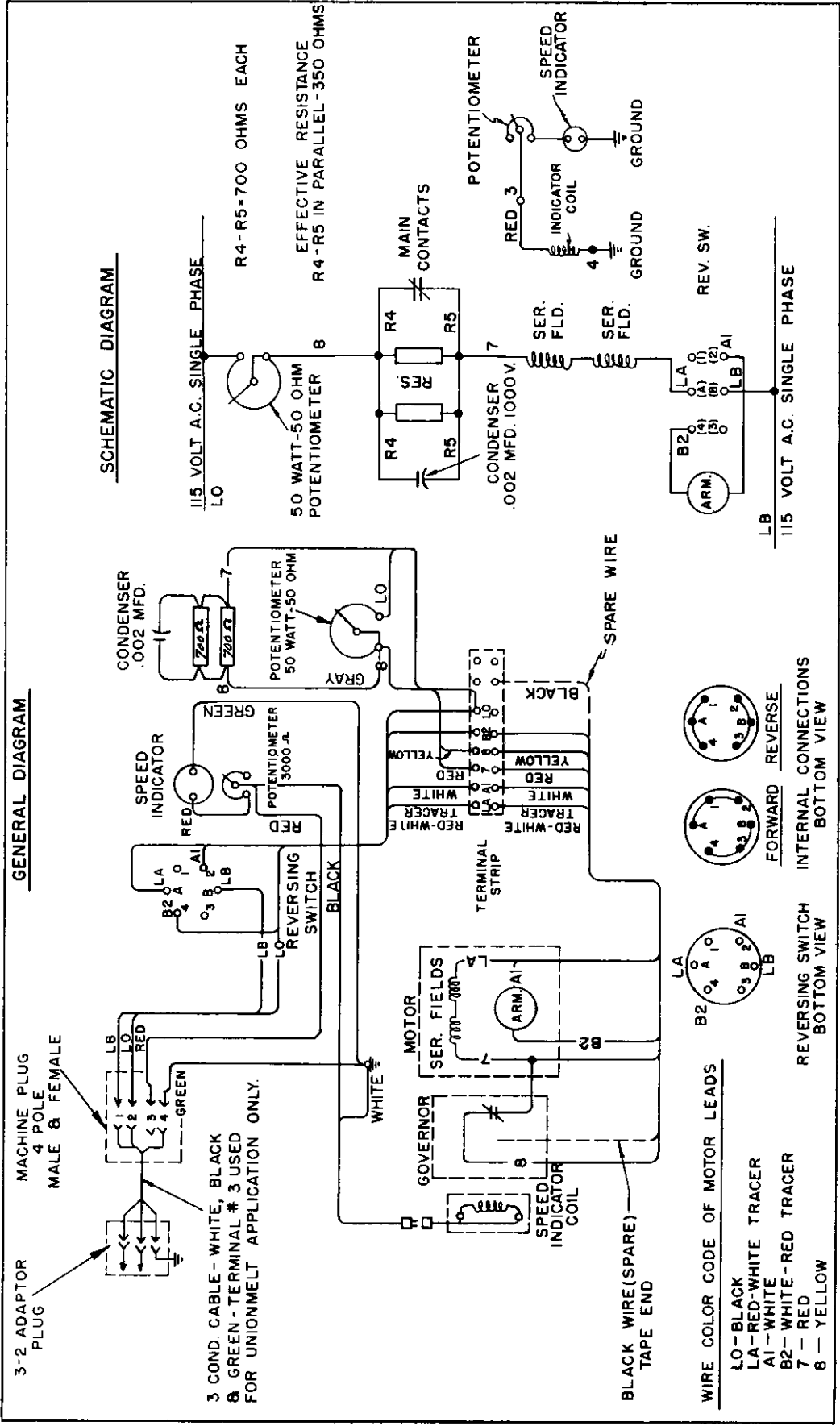

FIG. 28 - CM-37 (Series 2) Electrical Wiring Diagram

Hardware List
FOR
CM-37 (SERIES 2) MACHINE CARRIAGE

<u>Part No.</u>	<u>Description</u>	<u>Part No.</u>	<u>Description</u>
6110-0849	#6-32 x 1/4-in. Fillister Head Brass Machine Screw	6133-9585	1/2-13 x 1/2-in. Slotted, Headless Cup Point Setscrew
6110-0852	#6-32 x 1/2-in. Fillister Head Brass Machine Screw	6134-0462	1/4-28 x 3/4-in. Socket Head Cap Screw
6110-0990	#2-56 x 3/16-in. Fillister Head Brass Machine Screw	6134-0903	#10-24 x 5/8-in. Socket-Head Cap Screw
6110-1635	#5-40 x 1-in. Round-Head Brass Machine Screw	6134-0969	#10-24 x 1-1/4-in. Socket-Head Cap Screw
6110-1815	#2-56 x 1/4-in. Round-Head Brass Machine Screw	6134-1096	1/4-28 x 1/2-in. Hex Head Cap Screw
6110-1960	#4-40 x 3/16-in. Round-Head Brass Machine Screw	6134-1113	5/16-18 x 1-in. Hex Head Cap Screw
6130-0824	#4-40 x 1/4-in. Fillister Head Machine Screw	6134-5876	#8-32 x 1/4-in. Socket Button-Head Cap Screw
6130-0825	#4-40 x 5/16-in. Fillister Head Machine Screw	6136-1657	#4-40 x 1-1/4-in. Round-Head Phillips Machine Screw
6130-0826	#4-40 x 3/8-in. Fillister Head Machine Screw	6136-1849	#6-32 x 1/4-in. Round-Head Phillips Machine Screw
6130-0851	#6-32 x 3/8-in. Fillister Head Machine Screw	6136-1880	#8-32 x 1/2-in. Round-Head Phillips Machine Screw
6130-0854	#6-32 x 3/4-in. Fillister Head Machine Screw	6136-1900	#10-24 x 3/8-in. Round-Head Phillips Machine Screw
6130-0960	#4-40 x 3/16-in. Fillister Head Machine Screw	6137-0580	5/16-24 x 5/32-in. Mac-It-Hollow Lock Screw
6130-1843	#5-40 x 5/8-in. Round-Head Machine Screw	6216-6321	#20 B&S Ga. .032 x 3/4-in. Brass Escutcheon Pin
6130-1848	#6-32 x 3/16-in. Round-Head Machine Screw	6223-0341	#22 x 1-in. Taper Pin
6130-1849	#6-32 x 1/4-in. Round-Head Machine Screw	6225-0009	Roll Pin - Esna - 59-014-.062-.625
6130-1850	#6-32 x 5/16-in. Round-Head Machine Screw	6225-0029	Roll Pin - Esna - 59-028-.125-0.875
6130-1853	#6-32 x 5/8-in. Round-Head Machine Screw	6225-0035	Roll Pin - Esna - 59-028-.125-1.250
6130-1855	#6-32 x 7/8-in. Round-Head Machine Screw	6225-0049	Roll Pin - Esna - 59-032-.156-1.000
6130-1876	#8-32 x 1/4-in. Round-Head Machine Screw	6225-0053	Roll Pin - Esna - 59-040-.187-1.250
6130-1880	#8-32 x 1/2-in. Round-Head Machine Screw	6310-0986	#5-40 Hex Brass Nut
6130-1915	#8-32 x 1-1/4-in. Round-Head Machine Screw	6313-0833	#4-40 Hex Brass Cap Nut
6130-3904	#10-24 x 3/4-in. Lg. Flat Head Machine Screw	6320-0742	#10-24 Hex Nut
6130-9900	#10-24 x 3/8-in. Flat-Head Phillips Machine Screw	6320-0862	#6-32 Hex Nut
6130-9903	#10-24 x 5/8-in. Flat-Head Phillips Machine Screw	6320-0886	#8-32 Hex Nut
6132-0812	#2 x 1/4-in. Parker Kalon Type "U" Drive Screw	6320-0986	#5-40 Hex Nut
6132-0821	#4 x 1/4-in. Parker Kalon Type "U" Drive Screw	6334-0152	7/16-in. -20 Hex Jam Nut
6133-0084	1/4-20 x 1/4-in. Socket Headless, Cup Point, Setscrew	6334-0230	5/8-in. -18 Hex Jam Nut
6133-0900	#10-24 x 3/8-in. Socket Headless Cup Point Setscrew	6410-4987	#5 SAE Brass Washer
6133-9086	1/4-20 x 3/8-in. Slotted, Headless, Cup Point Setscrew	6410-9837	#4 Brass Washer (ASA Light)
6133-9170	5/16-24 x 7/8-in. Socket Headless, Round Point, Setscrew	6420-2337	1/4 x 7/64 x 3/64-in. Lock Washer
6133-9556	5/16-24 x 5/16-in. Mag-It-Hollow Cup Point Setscrew	6420-2571	5/16 x 1/8 x 5/64-in. Lock Washer
		6420-2643	#5 x .040 x .025 in. Machine Screw Lock Washer
		6420-2686	#8 x 3/64 x 1/32-in. Machine Screw Lock Washer
		6420-2837	#4 x 1/32 x 1/32-in. Machine Screw Lock Washer
		6420-2859	#6 x 3/64 x 1/32-in. Machine Screw Lock Washer
		6420-4860	#6 SAE Plain Washer
		6420-8920	#10 x 1/16 x 3/64-in. SAE Machine Screw Lock Washer
		6627-0179	1/2-13 x 1-3/4-in. Sock-Head Shoulder Cap Screw
		6825-0204	#204 Woodruff Key
		6825-0405	#405 Woodruff Key
		7363-5316	Simplex-Tirex Type "SO" 16 Ga. Rubber Clad, 3-Cond. Cord, 25-ft. lg.
		7363-5861	G.E. Flex, Type "SJ" 18 Ga. 2 Conductor Cord 21-in. Long
		9086-0050	Mitchell Rand Co.'s Black Mirac Tubing Size 1/2-in., Approx.

IX. Speed Conversion

To provide still greater flexibility, and to more readily adapt the CM-37 to individual requirements, there has been made available a series of gear reduction units which will enable the customer to select an operating range or ranges most suitable to his particular applications.

This section provides instructions for customers desiring to convert any of the four models for operation within a new speed range, either by (1) substitution of an entire motor gear head reduction unit, (2) by gear substitution within the motor gear head reduction unit, or (3) by changing a portion of the chassis gear train. The first method is the most practical in cases where it is desired to have several interchange-

able ratios on hand, being the one most easy to accomplish, while the latter methods are used for changes of a more permanent nature.

Gear Reduction Unit and Speed Ranges

The motor Gear Head Reduction Unit is a double reduction unit. It consists of a primary stage and a secondary (output) stage. Motor Gear Head Reduction units are kept in stock in the following ratios, giving machine speed ranges as indicated. Those marked "Special" are not stocked as complete units. However, output gears and worms to provide these ratios are obtainable, as indicated in the lower table.

Part No.	Ratio	Machine Speed Range (ipm)	
		Standard, Intermediate & High-Speed Machine	Low-Speed Machine
Special	108:1	31 to 382	7-3/4 to 115
50V59	200:1	20 to 210	4-1/2 to 62
Special	288:1	11-3/4 to 144	3 to 43-1/4
51V18	416:1	10 to 105	2 to 30
50V57	832:1	4 to 50	1 to 15
Special	1024:1	3-1/2 to 40-1/2	7/8 to 12

The following table shows the component parts of the output (secondary) stage in each of the above gear reduction units. This is for use in the event that it is required to change speed range by alteration of the internal stage instead of by substituting an entire unit. (Primary stage gears are the same for all gear units.)

Ratio	Countershaft & Worm Part No.	No. Threads	Extension Shaft Worm Gear Part No.	No. Teeth
108:1*	02N38	8	02N39	27
200:1	55W07	4	55W09	25
288:1*	02N26	3	02N05	27
416:1	02N40	2	02N41	26
832:1	54W97	1	55W03	26
1024:1*	02N29	1	02N23	32

*When these ratios are used, a blank dial must be installed in the speedometer and calibrated to the machine in small steps all across the dial, or a calibration chart must be computed.

SPEED CONVERSION CHART

TO CONVERT	TO	REQUIRES
Low-Speed	Standard-Speed	1. Replacement of worm and clutch gear (see Sec. B). 2. Replacement of speedometer with speedometer 37V09.
	Intermediate-Speed	1. Replacement of gear unit by gear unit 51V18 (see Sec. A). 2. Replacement of worm and clutch gear (see Sec. B). 3. Replacement of speedometer by speedometer 37V70.
	High-Speed	1. Replacement of gear unit by gear unit 50V59 (see Sec. A). 2. Replacement of worm and clutch gear (see Sec. B). 3. Replacement of speedometer by speedometer 37V30.
Standard-Speed	Low-Speed	1. Replacement of worm and clutch gear (see Sec. B). 2. Replacement of speedometer by speedometer 37V35.
	Intermediate-Speed	1. Replacement of gear unit by gear unit 51V18 (see Sec. A). 2. Replacement of speedometer by speedometer 37V70.
	High-Speed	1. Replacement of gear unit by gear unit 50V59 (see Sec. A). 2. Replacement of speedometer by speedometer 37V30.
Intermediate-Speed	Low-Speed	1. Replacement of gear unit by gear unit 50V57 (see Sec. A). 2. Replacement of worm and clutch gear (see Sec. B). 3. Replacement of speedometer with speedometer 37V35.
	Standard-Speed	1. Replacement of gear unit by gear unit 50V57 (see Sec. A). 2. Replacement of speedometer by speedometer 37V09.
	High-Speed	1. Replacement of gear unit by gear unit 50V59 (see Sec. A). 2. Replacement of speedometer by speedometer 37V30.
High-Speed	Low-Speed	1. Replacement of gear unit by gear unit 50V57 (see Sec. A). 2. Replacement of worm and clutch gear (see Sec. B). 3. Replacement of speedometer by speedometer 37V35.
	Standard-Speed	1. Replacement of gear unit by gear unit 50V57 (see Sec. A). 2. Replacement of speedometer by speedometer 37V09.
	Intermediate-Speed	1. Replacement of gear unit by gear unit 51V18 (see Sec. A). 2. Replacement of speedometer by speedometer 37V70.

A. Replacement of Entire Gear Unit or its Output Stage Gearing

1. Remove the Motor-Governor-Gear Reduction Unit Assembly as directed in Section V-A.
2. Remove the Gear Reduction Unit from the motor by withdrawing the four screws which fasten it to the motor housing. If the unit does not dismount easily, tapping with a rawhide mallet on several sides will help loosen the seal. The gasket inserted between the motor and gear unit should be retained on the gear unit housing.
3. Clean out the grease which fills the gear unit.
4. Remove the coupling from the output shaft of the gear unit by driving out the pin which secures it.
5. If the entire gear reduction unit is to be replaced, the coupling removed in Step 4 must be transferred to the new gear reduction unit. Using a 1/8-in. (.125 + .003 - .001) drill, drill and ream a hole in the output shaft for the taper pin. (When assembled, the end of the output shaft should be flush with the bottom of the slot in the coupling.) After installing the coupling, fill the new gear reduction unit with Royco #6A grease. Mount the unit on the motor and reassemble the equipment.
6. Withdraw the extension (output) shaft and worm gear assembly from the gear reduction unit housing.
7. Remove the worm gear from the shaft by driving out the pin in the gear hub, and replace with the new worm gear (hub toward the coupling end of the shaft, and loose spacer sleeve on the hub side of gear).
8. Loosen the two socket-head setscrews in the hub of the countershaft worm gear.
9. Remove the cap in the housing at the worm end of the countershaft and remove the end thrust bearing parts, being careful not to lose the loose ball bearings.
10. Remove the countershaft by sliding it out through the bearing opening.
11. Install the new countershaft, assembling the original countershaft worm gear to it, hub toward the worm, and tighten the setscrews in the gear hub into the drilled spots in the countershaft.

If it is proposed to replace only the gearing in the output stage of the gear reduction unit, the following procedure applies: (Refer to Fig. 27)

12. Replace the end bearing parts, if they have become separated, in the following order: pivot, 9 ball bearings (use grease to hold them in place), cup, flet pad, then the bearing cap.
13. Replace the output shaft, then the output shaft coupling and taper pin. Fill the gear unit with Royco #6A grease.
14. Assemble the gear reduction unit to the motor in its original position.
15. Reinstall the assembly in the carriage. Do not forget to insert the coupling block which links the output shaft to the worm drive shaft in the carriage.
16. To replace the speedometer:
 - (a) Remove the three cap nuts which hold the speedometer and its lens in the carriage.
 - (b) Lift out the lens, and remove the three mounting springs beneath.
 - (c) Lift out the speedometer and disconnect from it the cable lead and the rheostat.
 - (d) Connect the cable lead and rheostat to the terminals of the new speedometer in the same positions they occupied on the old speedometer.
 - (e) Replace the speedometer in the carriage, and reassemble the springs, lens, and cap nuts.
 - (f) Check the speedometer calibration as outlined in Sec. IV-B.

B. Replacement of Worm and Clutch Gear

Two worm-and-gear sets are used in the four models of the CM-37. One set is used in the Low-

Speed carriage. The other is used in the Standard-, Intermediate-, and High-Speed carriages. When converting to, or from, the low-speed range it will be necessary to install the appropriate worm and gear. Part numbers are as follows:

<u>Speed Range</u>	<u>Worm Part No.</u>	<u>No. Threads</u>	<u>Gear Part No.</u>	<u>No. Teeth</u>
High, Intermediate, and Standard	37N40	8	38N32	23
Low	37N89	2	38N33	23

Conversion procedure:

1. Disassemble the front axle group and the worm drive shaft group from the carriage as directed in Section V-B.
2. Remove from the worm drive shaft the locknut, retaining nut, bearing, and spacer, as shown in Figure 19.
3. Slide the worm off the shaft, and substitute the new worm.
4. Reassemble the parts on the **worm driveshaft**, and install the group in the carriage.
5. Install the front axle group in the carriage, substituting the new gear in place of the old clutch drive gear.
6. Swab the worm and gear with Royco #6A grease.
7. Replace the gear box cover, making sure that its gasket is still intact and forms a good seal.
8. Replace the speedometer with the new speedometer and calibrate, as outlined in part A of Section IX.

**UNION CARBIDE CORPORATION
LINDE DIVISION**

GENERAL OFFICES: NEW YORK
OFFICES IN PRINCIPAL CITIES

In Canada

UNION CARBIDE CANADA LIMITED, TORONTO

Outside U.S. and Canada

ENGINEERING PRODUCTS DEPARTMENT
UNION CARBIDE INTERNATIONAL COMPANY
DIVISION OF UNION CARBIDE CORPORATION
270 PARK AVE N.Y. N.Y. 10017



GAS PRODUCTS